

When you move. We move.

Rollon S.p.A. was founded in 1975 as a manufacturer of linear motion components. Today Rollon group is a leading name in the design, production, and sale of linear rails, telescopic rails, and actuators, with headquarters based in Italy and offices and distributors located throughout the world. Rollon products are used in many industries, providing creative and efficient solutions in a wide variety of applications.

Rollon solutions for linear motion

Linear Line



Telescopic Line



Actuator Line



Actuator System Line



Linear Rails

- Rails with roller bearings
- Rails with caged ball bearings
- Rails with recirculating ball bearing

Telescopic Rails

- Rails with partial/total extension
- Heavy duty rails
- Rails for automated and manual applications

Actuators

- Belt driven actuators
- Ball screw driven actuators
- Rack and pinion actuators

Solutions for industrial automation

- Multi-axis for pick and place
- Telescopic actuators
- Seventh axis for robots
- Solutions for metal sheet handling

Core Competencies

- > Full range of linear rails, telescopic rails and actuators
- > Worldwide presence with branches and distributors
- > Fast delivery all over the world
- > Large technical know-how for applications



> Standard solutions

Wide range of products and sizes
Linear rails with roller and caged ball bearings
Heavy duty telescopic rails
Belt or ball screw driven linear actuators
Multi-axis systems



> Collaboration

International know-how in several industries
Project consultancy
Maximizing performance and cost optimization



> Customization

Special products
Research and development of new solutions
Technologies dedicated to different sectors
Optimal surface treatment



Applications

Aerospace



Railway

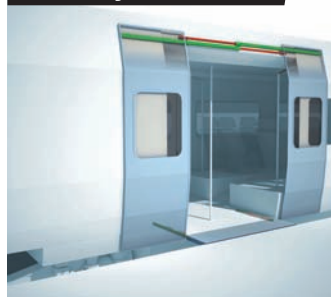

Logistics



Industrial



Medical



Special Vehicles



Robotics

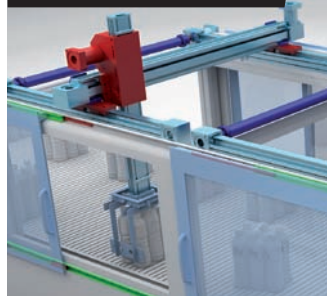

Packaging

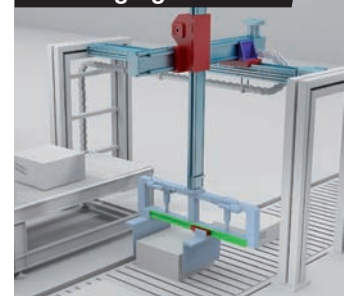

> Plus System



Technical features overview

1 ELM series

ELM series description	PLS-2
The components	PLS-3
The linear motion system	PLS-4
ELM 50 SP - ELM 50 CI	PLS-5
ELM 65 SP - ELM 65 CI	PLS-6
ELM 80 SP - ELM 80 CI	PLS-7
ELM 110 SP - ELM 110 CI	PLS-8
Lubrication, Planetary gear	PLS-9
Simple shaft	PLS-10
Hollow shafts	PLS-11
Linear units parallel, Accessories	PLS-12
Ordering key	PLS-14

2 ROBOT series

ROBOT series description	PLS-15
The components	PLS-16
The linear motion system	PLS-17
ROBOT 100 SP	PLS-18
ROBOT 100 SP-2C	PLS-19
ROBOT 100 CE	PLS-20
ROBOT 100 CE-2C	PLS-21
ROBOT 130 SP	PLS-22
ROBOT 130 SP-2C	PLS-23
ROBOT 130 CE	PLS-24
ROBOT 130 CE-2C	PLS-25
ROBOT 160 SP	PLS-26
ROBOT 160 SP-2C	PLS-27
ROBOT 160 CE	PLS-28
ROBOT 160 CE-2C	PLS-29
ROBOT 220 SP	PLS-30
ROBOT 220 SP-2C	PLS-31
Lubrication, Planetary gear	PLS-32
Simple shaft	PLS-33
Hollow shafts, Accessories	PLS-34
Ordering key	PLS-39

3 SC series

SC series description	PLS-40
The components	PLS-41
The linear motion system	PLS-42
SC 65 SP	PLS-43
SC 130 SP	PLS-44
SC 160 SP	PLS-45
Lubrication, Planetary gear	PLS-46
Simple shaft, Hollow shafts	PLS-47
Accessories	PLS-48
Ordering key	PLS-51
Multiaxis systems	PLS-52

> Clean Room System



1 ONE series

ONE series description	CRS-2
The components	CRS-3
The linear motion system	CRS-4
ONE 50	CRS-5
ONE 80	CRS-6
ONE 110	CRS-7
Planetary gear	CRS-8
Accessories	CRS-9
Ordering key	CRS-11

> Smart System



1 E-SMART series

E-SMART series description	SS-2
The components	SS-3
The linear motion system	SS-4
E-SMART 30 SP2	SS-5
E-SMART 50 SP1 - SP2 - SP3	SS-6
E-SMART 80 SP1 - SP2	SS-7
E-SMART 80 SP3 - SP4	SS-8
E-SMART 100 SP1 - SP2	SS-9
E-SMART 100 SP3 - SP4	SS-10
Lubrication	SS-11
Simple shafts, Hollow shaft	SS-12
Linear units in parallel, Accessories	SS-13
Ordering key	SS-16

2 R-SMART series

R-SMART series description	SS-17
The components	SS-18
The linear motion system	SS-19
R-SMART 120 SP4 - SP6	SS-20
R-SMART 160 SP4 - SP6	SS-21
R-SMART 220 SP4 - SP6	SS-22
Lubrication	SS-23
Simple shafts, Hollow shaft	SS-24
Accessories	SS-25
Ordering key	SS-29

3 S-SMART series

S-SMART series description	SS-30
The components	SS-31
The linear motion system	SS-32
S-SMART 50 SP	SS-33
S-SMART 65 SP	SS-34
S-SMART 80 SP	SS-35
Lubrication	SS-36
Simple shafts, Hollow shaft	SS-37
Accessories	SS-38
Ordering key	SS-41

Multiaxis systems	SS-42
-------------------	-------

> Eco System



1 ECO series

ECO series description	ES-2
The components	ES-3
The linear motion system	ES-4
ECO 60 SP2 - ECO 60 CI	ES-5
ECO 80 SP2 - ECO 80 SP1 - ECO 80 CI	ES-6
ECO 100 SP2 - ECO 100 SP1 - ECO 100 CI	ES-7
Simple shafts, Hollow shafts	ES-8
Linear units in parallel, Accessories	ES-9
Ordering key	ES-12
Multiaxis systems	ES-13

> Uniline System



1 Uniline A series

Uniline A series description	US-2
The components	US-3
A40	US-4
A55	US-6
A75	US-8
A100	US-10
Lubrication	US-14
Accessories	US-15
Ordering key	US-18

2 Uniline C series

Uniline C series description	US-20
The components	US-21
C55	US-22
C75	US-24
Lubrication	US-26
Accessories	US-27
Ordering key	US-30

3 Uniline E series

Uniline E series description	US-32
The components	US-33
E55	US-34
E75	US-36
Lubrication	US-38
Accessories	US-39
Ordering key	US-42

4 Uniline ED series

Uniline ED series description	US-44
The components	US-45
ED75	US-46
Lubrication	US-48
Accessories	US-49
Ordering key	US-52

5 Uniline H series

Uniline H series description	US-54
------------------------------	-------

The components	US-55
H40	US-56
H55	US-57
H75	US-58
Lubrication	US-59
Accessories	US-60
Ordering key	US-62

6 Belt tension	US-63
-----------------------	-------

7 Installation instructions	US-65
------------------------------------	-------

> Precision System



1 TH series	
TH series description	PS-2
The components	PS-3
TH 90 SP2	PS-4
TH 90 SP4	PS-5
TH 110 SP2	PS-6
TH 110 SP4	PS-7
TH 145 SP2	PS-8
TH 145 SP4	PS-9
Motor connections	PS-10
Lubrication	PS-11
Critical speed, Calculation factors	PS-12
Accessories	PS-14
Ordering key	PS-19

2 TT series	
TT series description	PS-20
The components	PS-21
TT 100	PS-22
TT 155	PS-24
TT 225	PS-26
TT 310	PS-28
Lubrication	PS-30
Accuracy certificate	PS-31
Critical speed, Calculation factors	PS-33
Accessories	PS-35
Ordering key	PS-38

3 TV series	
TV series description	PS-39
The components	PS-40
TV 60	PS-41
TV 80	PS-42
TV 110	PS-43
TV 140	PS-44
Lubrication	PS-45
Critical speed, Calculation factors	PS-46
Accessories	PS-48
Ordering key	PS-50

4 TK series	
TK series description	PS-52
The components	PS-53
TK 40	PS-54

TK 60	PS-56
TK 80	PS-58
Critical speed	PS-60
Ordering key	PS-61
Multiaxis systems	PS-62

Static load and service life Plus-Clean Room-Smart-Eco-Precision	SL-2
Static load and service life Uniline	SL-4
Data sheet	SL-9

Technical features overview



Reference		Section		Driving			Anticorrosion	Protection	
Family	Product	Balls	Rollers	Toothed belt	Ball screw	Rack and pinion			
Plus System		ELM							
		ROBOT							
		SC							
Clean Room System		ONE							
Smart System		E-SMART							
		R-SMART							
		S-SMART							
Eco System		ECO							
Uniline System		A/C/E/ED/H							
Precision System		TH							
		TT							
		TV							
		TK							

Reported data must be verified according to the application. See verification under static load and lifetime on page SL-2 and SL-7
 For a complete overview about technical data, please consult our catalogues at www.rollon.com.

* Longer stroke is available for jointed version

Size	Max. load capacity per carriage [N]			Max. static moment per carriage [Nm]			Max. travel speed [m/s]	Max. acceleration [m/s ²]	Repeatability accuracy [mm]	Max. travel or stroke (per system) [mm]	
	F _x	F _y	F _z	M _x	M _y	M _z					
50-65-80-110	4440	79000	79000	1180	7110	7110	5	50	± 0,05	6000*	P L S
100-130-160-220	8510	158000	158000	13588	17696	17696	5	50	± 0,05	6000*	
65-130-160	5957	86800	86800	6770	17577	17577	5	50	± 0,05	2500	
50-80-110	4440	92300	110760	1110	9968	8307	5	50	± 0,05	6000*	C R S
30-50-80-100	4440	87240	87240	1000	5527	5527	4	50	± 0,05	6000*	S S
120-160-220	8880	237000	237000	20145	30810	30810	4	50	± 0,05	6000*	
50-65-80	2250	51260	51260	520	3742	3742	4	50	± 0,05	2000	
60-80-100	4070	43400	43400	570	4297	4297	5	50	± 0,05	6000*	
40-55-75-100	1000	25000	17400	800,4	24917	15752	9	20	± 0,05	5700*	E S
90-110-145	27000	86800	86800	3776	2855	2855	2		± 0,005	1500	U S
100-155-225-310	58300	230580	274500	30195	26627	22366	2,5		± 0,005	3000	P S
60-80-110-140	58300	48400	48400	2251	3049	3049	2,5		± 0,01	4000	
40-60-80	12462	50764	50764	1507	622	622	1,48		± 0,003	810	

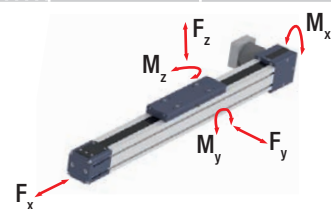

ROLLON[®]
Linear Evolution

Plus System



ELM series



> ELM series description



Fig. 1

ELM

This is Rollon's highly versatile, premier line of completely enclosed belt drive linear actuators.

The ELM linear units are available in four sizes from 50 mm to 110 mm. They have a self-supporting structure with a robust profile of extruded and anodized aluminum. The thrust force is transmitted by a steel reinforced, polyurethane. The moving carriage is precisely guided and supported by a linear guide system or optional cam roller system.

A polyurethane sealing strip ensures complete protection of the belt drive and linear guide system against dust, dirt, chips, liquids and other contaminants. It avoids the fragility of other sealing systems such as stainless steel strips.

The components used for linear motion, lubricant reservoir, caged ball bearing blocks and double-lip seals; promote a "maintenance-free" system. The pulleys, bearings and drive shafts are among the most robust in the industry. ELM is the best product for applications in very aggressive working environments that also require high speed duty cycles and position repeatability.

Corrosion resistant version

All Plus System series of linear actuators are available with stainless steel elements, for applications in harsh environments and/or subject to frequent washes.

The Plus System linear units are constructed using extruded anodized 6060 and 6082 Anti-Corrosive Aluminum, which houses bearings, linear rails, nuts and bolts and components made stainless steel, preventing or delaying corrosion caused by humidity experienced in the environments where the linear units are used.

Special no-deposit surface treatments are combined with a food grade lubrication system to allow use in highly sensitive applications, such as the food and pharmaceutical industries where product contamination is prohibited.

- Internal stainless steel elements
- Anodized 6060 and 6082 Anti-Corrosive Aluminum Profile
- AISI 440 stainless steel linear rails
- Lubricated with organic food grade vegetable oils

> The components

Extruded profile

The anodized 6060 aluminum alloy extrusion used for the profile of the Rollon ELM series linear units were designed and manufactured by industry experts to optimize weight while maintaining mechanical strength. (see physical-chemical characteristics below). The dimensional tolerances comply with EN 755-9 standard.

Driving belt

The Rollon ELM series linear units use steel reinforced polyurethane drive belts with AT pitch. This belt is ideal due to its high load transmission characteristics, compact size and low noise. Used in conjunction with a backlash-free pulley, smooth alternating motion can be achieved. Optimization of the maximum belt width/body dimension ratio enables the following performance characteristics to be achieved:

- High speed
- Low noise
- Low wear

Carriage

The carriage of the Rollon ELM series linear units are made entirely of anodized aluminum. Each carriage has mounting holes fitted with stainless steel thread inserts. Rollon offers multiple carriages to accommodate a vast array of applications. The unique design of the carriage allows for the sealing strip to pass through the carriage as well as house brush seals to remove contaminants from the sealing strip.

Sealing strip

Rollon ELM series linear units are equipped with a polyurethane sealing strip to protect all of the internal components from dust, contaminants, and other foreign objects. The sealing strip runs the length of the body and is kept in position by micro-bearings located inside the carriage. This minimizes frictional resistance as the strip passes through the carriage while providing maximum protection.

General data about aluminum used: AL 6060

Chemical composition [%]

Al	Mg	Si	Fe	Mn	Zn	Cu	Impurities
Remainder	0.35-0.60	0.30-0.60	0.30	0.10	0.10	0.10	0.05-0.15

Tab. 1

Physical characteristics

Density	Coeff. of elasticity	Coeff. of thermal expansion (20°-100°C)	Thermal conductivity (20°C)	Specific heat (0°-100°C)	Resistivity	Melting point
$\frac{\text{kg}}{\text{dm}^3}$	$\frac{\text{kN}}{\text{mm}^2}$	$\frac{10^{-6}}{\text{K}}$	$\frac{\text{W}}{\text{m} \cdot \text{K}}$	$\frac{\text{J}}{\text{kg} \cdot \text{K}}$	$\Omega \cdot \text{m} \cdot 10^{-9}$	°C
2.7	69	23	200	880-900	33	600-655

Tab. 2

Mechanical characteristics

Rm	Rp (02)	A	HB
$\frac{\text{N}}{\text{mm}^2}$	$\frac{\text{N}}{\text{mm}^2}$	%	—
205	165	10	60-80

Tab. 3

> The linear motion system

The linear motion system has been designed to meet the load capacity, speed, and maximum acceleration conditions of a wide variety of applications. Two linear motion systems are offered:

ELM...SP with ball bearing guides

- A ball bearing guide with high load capacity is mounted in a dedicated seat inside the body.
- The carriage is assembled on two pre-loaded ball bearing blocks.
- The two ball bearing blocks enable the carriage to withstand loading in the four main directions.
- The two blocks have seals on both sides and, if necessary, an additional scraper can be fitted for very dusty conditions.
- The ball bearing carriages of the SP versions are also fitted with a retention cage that eliminates "steel-steel" contact between adjacent revolving parts and prevents misalignment.
- Lubrication reservoirs (pockets) installed on the front of the ball bearing blocks supply the right amount of grease, thus promoting long maintenance interval.

The linear motion system described above offers:

- High speed and acceleration
- High load capacity
- High permissible bending moments
- Low friction
- Long life
- Maintenance free (depending on applications)
- Low noise

ELM...CI with gothic arch bearing guides inside the body

- Two hardened steel rods (58/60 HRC tolerance h6) are securely inserted inside the aluminum body.
- The carriage is fitted with six bearing assemblies each having a gothic arch groove machined into its outer race to run on the steel rods.
- The six bearings are mounted on steel pins, two of which are eccentric, to allow setting of running clearance and pre-load.
- To keep the running tracks clean and lubricated, four grease impregnated felt seals, complete with grease reservoirs, are fitted on the ends of the carriage.

The linear motion system described above offers:

- Good positioning accuracy
- Low noise
- Maintenance free (depending on applications)

ELM SP section

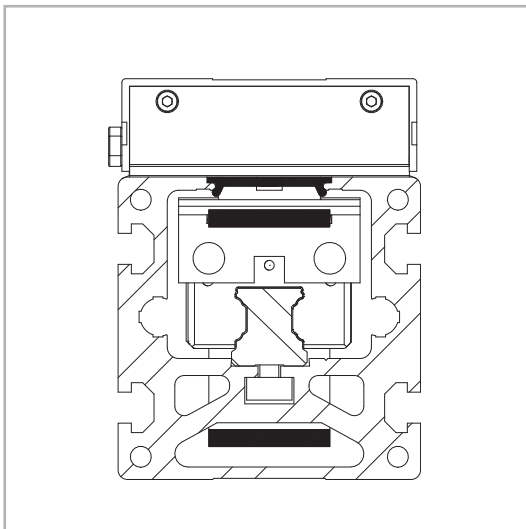

Fig. 2

ELM CI section

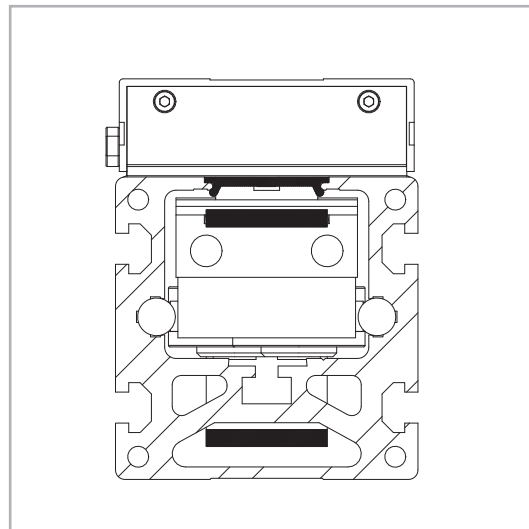
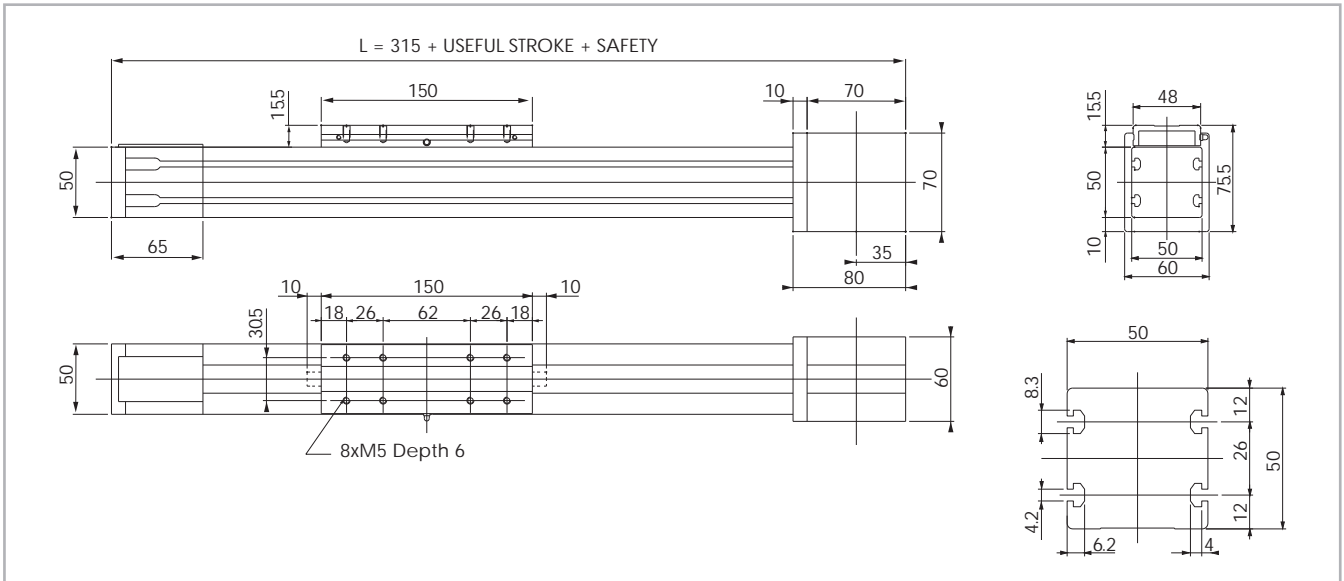

Fig. 3

> ELM 50 SP - ELM 50 CI

ELM 50 SP - ELM 50 CI Dimension



* The length of the safety stroke is provided on request according to the customer's specific requirements.

Fig. 4

Technical data

	Type	
	ELM 50 SP	ELM 50 CI
Max. useful stroke length [mm]	3700	6000*1
Max. positioning repeatability [mm]*2	± 0.05	± 0.05
Max. speed [m/s]	4.0	1.5
Max. acceleration [m/s ²]	50	1.5
Type of belt	22 AT 5	22 AT 5
Type of pulley	Z 23	Z 23
Pulley pitch diameter [mm]	36.61	36.61
Carriage displacement per pulley turn [mm]	115	115
Carriage weight [kg]	0.4	0.5
Zero travel weight [kg]	1.8	1.7
Weight for 100 mm useful stroke [kg]	0.4	0.3
Starting torque [Nm]	0.4	0.4
Moment of inertia of pulleys [g mm ²]	19810	19810

*1) It is possible to obtain strokes up to 9000 mm by means of special Rollon joints

*2) Positioning repeatability is dependent on the type of transmission used

Tab. 4

ELM 50 - Load capacity

Type	F _x [N]		F _y [N]		F _z [N]		M _x [Nm]		M _y [Nm]		M _z [Nm]	
	Stat.	Dyn.	Stat.	Dyn.	Stat.	Dyn.	Stat.	Dyn.	Stat.	Dyn.	Stat.	Dyn.
ELM 50 SP	809	508	7000	4492	7000	4492	42	27	231	148	231	148
ELM 50 CI	809	624	1480	2540	910	1410	16	25	36	55	58	99

See verification under static load and lifetime on page SL-2 and SL-3

Tab. 7

Moments of inertia of the aluminum body

Type	I _x [10 ⁷ mm ⁴]	I _y [10 ⁷ mm ⁴]	I _b [10 ⁷ mm ⁴]
ELM 50	0.025	0.031	0.056

Tab. 5

Driving belt

The driving belt is manufactured from a friction resistant polyurethane and with steel cords for high tensile stress resistance.

Type	Type of belt	Belt width [mm]	Weight kg/m
ELM 50	22 AT 5	22	0.072

Tab. 6

Belt length (mm) = 2 x L - 130 (SP and CI Models)

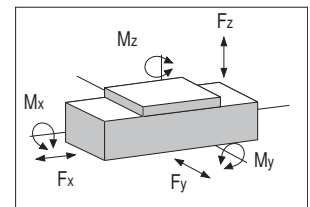

> ELM 65 SP - ELM 65 CI

ELM 65 SP - ELM 65 CI Dimension

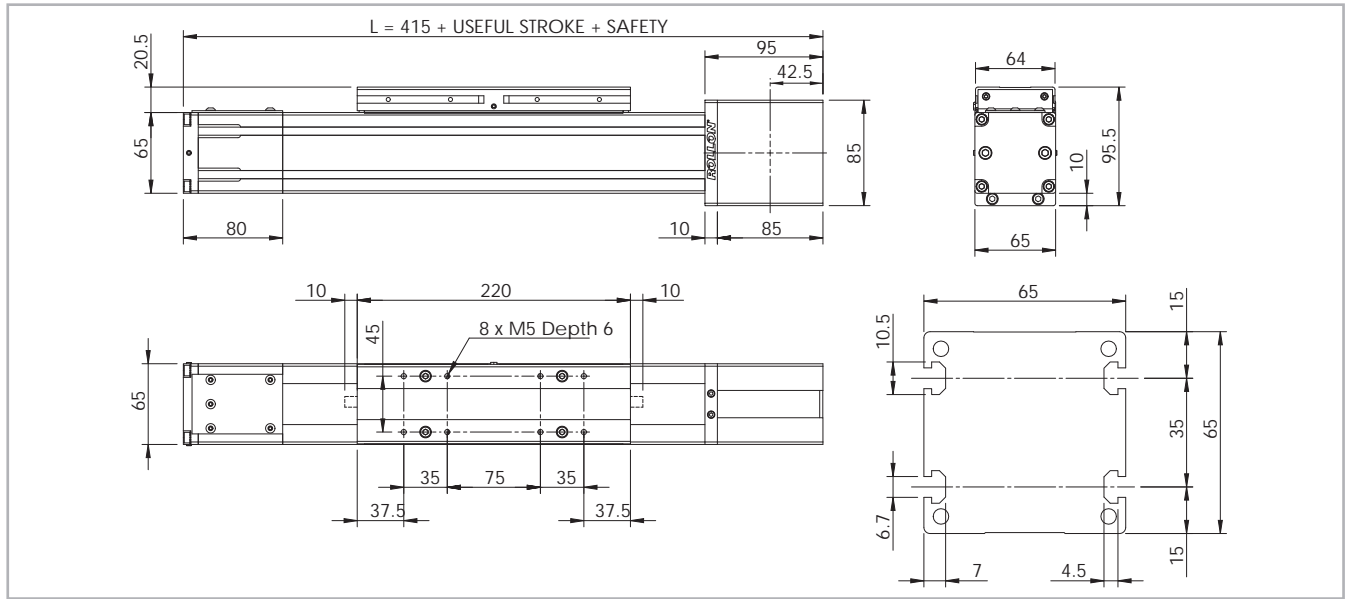

* The length of the safety stroke is provided on request according to the customer's specific requirements.

Fig. 5

Technical data

	Type	
	ELM 65 SP	ELM 65 CI
Max. useful stroke length [mm]*1	6000	6000
Max. positioning repeatability [mm]*2	± 0.05	± 0.05
Max. speed [m/s]	5.0	1.5
Max. acceleration [m/s ²]	50	1.5
Type of belt	32 AT 5	32 AT 5
Type of pulley	Z 32	Z 32
Pulley pitch diameter [mm]	50.93	50.93
Carriage displacement per pulley turn [mm]	160	160
Carriage weight [kg]	1.1	1.0
Zero travel weight [kg]	3.5	3.3
Weight for 100 mm useful stroke [kg]	0.6	0.5
Starting torque [Nm]	1.5	1.5
Moment of inertia of pulleys [g mm ²]	117200	117200

*1) It is possible to obtain strokes up to 11000 mm by means of special Rollon joints

*2) Positioning repeatability is dependent on the type of transmission used

Tab. 8

ELM 65 - Load capacity

Type	F _x [N]		F _y [N]		F _z [N]		M _x [Nm]		M _y [Nm]		M _z [Nm]	
	Stat.	Dyn.	Stat.	Dyn.	Stat.	Dyn.	Stat.	Dyn.	Stat.	Dyn.	Stat.	Dyn.
ELM 65 SP	1344	883	24200	14560	24200	14560	240	138	747	449	747	449
ELM 65 CI	1344	1075	3800	7340	2470	4080	58	96	100	170	160	310

See verification under static load and lifetime on page SL-2 and SL-3

Tab. 11

Moments of inertia of the aluminum body

Type	I _x [10 ⁷ mm ⁴]	I _y [10 ⁷ mm ⁴]	I _p [10 ⁷ mm ⁴]
ELM 65	0.060	0.086	0.146

Tab. 9

Driving belt

The driving belt is manufactured from a friction resistant polyurethane and with steel cords for high tensile stress resistance.

Type	Type of belt	Belt width [mm]	Weight kg/m
ELM 65	32 AT 5	32	0.105

Tab. 10

Belt length (mm) = 2 x L - 180 (SP model)

2 x L - 145 (CI model)

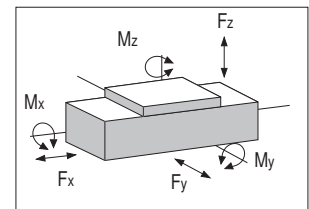

> ELM 80 SP - ELM 80 CI

ELM 80 SP - ELM 80 CI Dimension

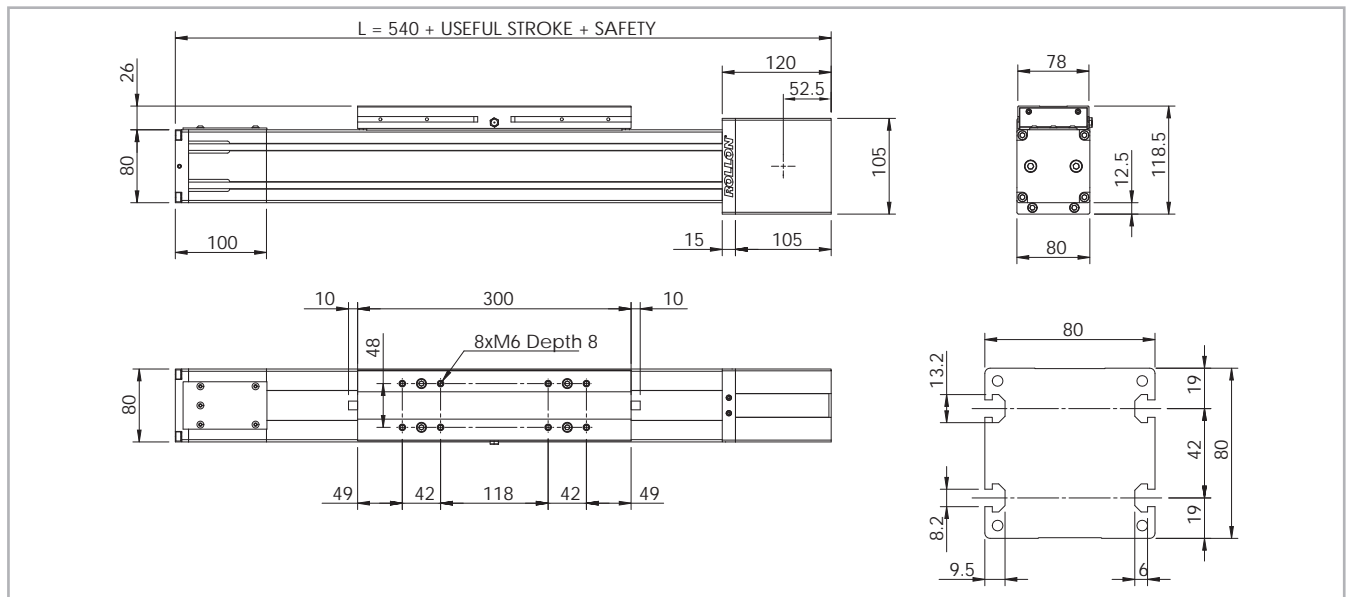

* The length of the safety stroke is provided on request according to the customer's specific requirements.

Fig. 6

Technical data

	Type	
	ELM 80 SP	ELM 80 CI
Max. useful stroke length [mm]*1	6000	6000
Max. positioning repeatability [mm]*2	± 0.05	± 0.05
Max. speed [m/s]	5.0	1.5
Max. acceleration [m/s ²]	50	1.5
Type of belt	32 AT 10	32 AT 10
Type of pulley	Z 19	Z 19
Pulley pitch diameter [mm]	60.48	60.48
Carriage displacement per pulley turn [mm]	190	190
Carriage weight [kg]	2.7	2.5
Zero travel weight [kg]	10.5	9.5
Weight for 100 mm useful stroke [kg]	1.0	0.8
Starting torque [Nm]	2.2	2.2
Moment of inertia of pulleys [g mm ²]	388075	388075

*1) It is possible to obtain strokes up to 11000 mm by means of special Rollon joints

*2) Positioning repeatability is dependent on the type of transmission used

Tab. 12

ELM 80 - Load capacity

Type	F _x [N]		F _y [N]		F _z [N]		M _x [Nm]		M _y [Nm]		M _z [Nm]	
	Stat.	Dyn.	Stat.	Dyn.	Stat.	Dyn.	Stat.	Dyn.	Stat.	Dyn.	Stat.	Dyn.
ELM 80 SP	2013	1170	43400	34800	43400	34800	570	440	3168	2540	3168	2540
ELM 80 CI	2013	1605	8500	17000	4740	8700	140	250	390	710	700	1390

See verification under static load and lifetime on page SL-2 and SL-3

Tab. 15

Moments of inertia of the aluminum body

Type	I _x [10 ⁷ mm ⁴]	I _y [10 ⁷ mm ⁴]	I _b [10 ⁷ mm ⁴]
ELM 80	0.136	0.195	0.331

Tab. 13

Driving belt

The driving belt is manufactured from a friction resistant polyurethane and with steel cords for high tensile stress resistance.

Type	Type of belt	Belt width [mm]	Weight kg/m
ELM 80	32 AT 10	32	0.185

Tab. 14

Belt length (mm) = 2 x L - 230 (SP and CI Models)

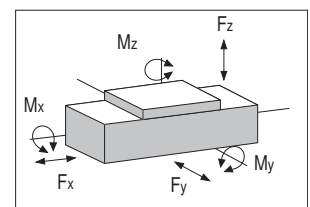

> ELM 110 SP - ELM 110 CI

ELM 110 SP - ELM 110 CI Dimension

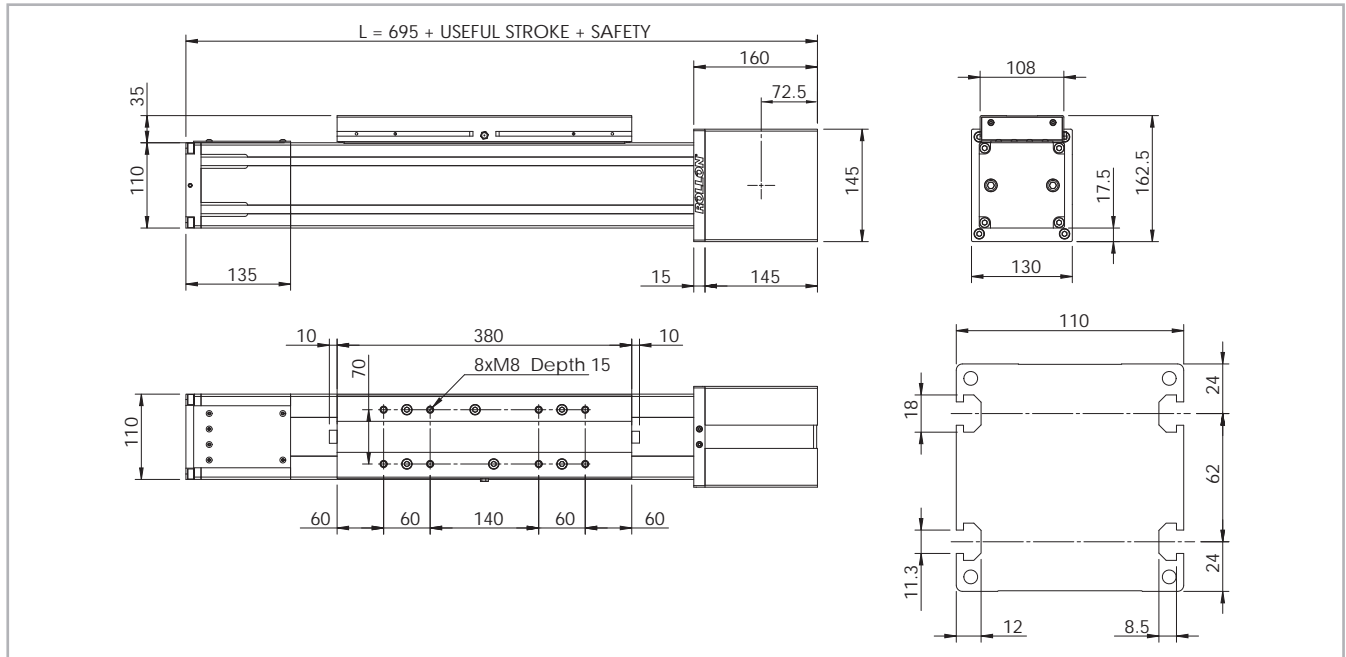

* The length of the safety stroke is provided on request according to the customer's specific requirements.

Fig. 7

Technical data

	Type	
	ELM 110 SP	ELM 110 CI
Max. useful stroke length [mm]*1	6000	6000
Max. positioning repeatability [mm]*2	± 0.05	± 0.05
Max. speed [m/s]	5.0	1.5
Max. acceleration [m/s ²]	50	1.5
Type of belt	50 AT 10	50 AT 10
Type of pulley	Z 27	Z 27
Pulley pitch diameter [mm]	85.94	85.94
Carriage displacement per pulley turn [mm]	270	270
Carriage weight [kg]	5.6	5.1
Zero travel weight [kg]	22.5	21.6
Weight for 100 mm useful stroke [kg]	1.4	1.1
Starting torque [Nm]	3.5	3.5
Moment of inertia of pulleys [g mm ²]	2.193·10 ⁶	2.193·10 ⁶

*1) It is possible to obtain strokes up to 11000 mm by means of special Rollon joints

*2) Positioning repeatability is dependent on the type of transmission used

Tab. 16

Moments of inertia of the aluminum body

Type	I _x [10 ⁷ mm ⁴]	I _y [10 ⁷ mm ⁴]	I _p [10 ⁷ mm ⁴]
ELM 110	0.446	0.609	1.054

Tab. 17

Driving belt

The driving belt is manufactured from a friction resistant polyurethane and with steel cords for high tensile stress resistance.

Type	Type of belt	Belt width [mm]	Weight kg/m
ELM 110	50 AT 10	50	0.290

Tab. 18

Belt length (mm) = 2 x L - 290 (SP and CI Models)

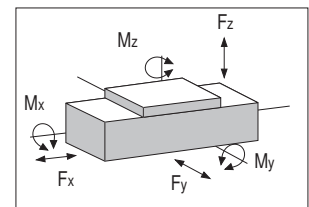

ELM 110 - Load capacity

Type	F _x [N]		F _y [N]		F _z [N]		M _x [Nm]		M _y [Nm]		M _z [Nm]	
	Stat.	Dyn.	Stat.	Dyn.	Stat.	Dyn.	Stat.	Dyn.	Stat.	Dyn.	Stat.	Dyn.
ELM 110 SP	4440	2940	79000	55000	79000	55000	1180	780	7110	4950	7110	4950
ELM 110 CI	4440	3660	19300	41700	12500	24500	330	650	960	1880	1480	3200

See verification under static load and lifetime on page SL-2 and SL-3

Tab. 19

> Lubrication

SP linear units with ball bearing guides

SP Linear units are equipped with self lubricating linear ball guides.

The ball bearing carriages of the SP versions are also fitted with a retention cage that eliminates "steel-steel" contact between adjacent revolving parts and prevents misalignment of these in the circuits.

Special lubrication reservoirs are mounted on the front plates of the linear blocks which continuously provide the necessary amount of grease to the ball raceways under load. These lubrication reservoirs also considerably reduce the frequency of lubrication of the module. This system guarantees

a long interval between maintenances: SP version: every 5000 km or 1 year of use, based on the value reached first. If a longer service life is required or in case of high dynamic or high loaded applications please contact our offices for further verification.

CI linear units with gothic arch bearing guides

Linear units with gothic arch bearing guides are equipped with an extended period lubrication system. Four grease impregnated felt scrapers, complete with grease reservoirs, guarantee a service life of ca. 6000 km without relubrication. If relubrication is required to obtain a higher service life please contact our offices.

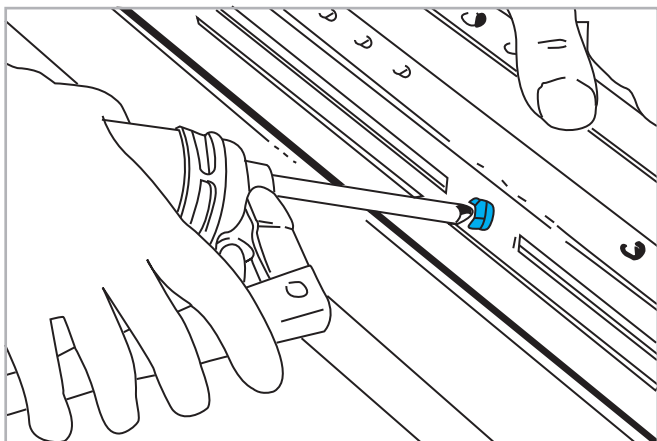

Fig. 8

- Insert the tip of the grease gun in the specific grease blocks.
- For lubrication of linear units use lithium soap grease NLGI 2.
- For specially stressed applications or difficult environmental

Quantity of lubricant necessary for re-lubrication:

Type	Unit: [g]
ELM 50 SP	1
ELM 65 SP	1.6
ELM 80 SP	2.8
ELM 110 SP	5.6

Tab. 20

conditions, lubrication should be carried out more frequently. Apply to Rollon for further advice.

> Planetary gears

Assembly to the right or to the left of the driving head

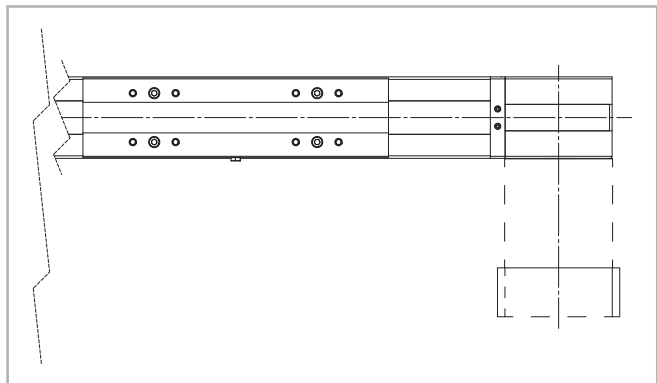
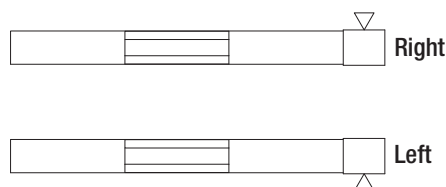

Fig. 9

The series ELM linear units can be fitted with several different drive systems. In each case, the driving pulley is attached to the reduction gearshaft by means of a tapered coupling to ensure high accuracy over a long period of time.

Versions with planetary gears

Planetary gears are used for highly dynamic robot, automation and handling applications involving stressing cycles and with high level precision requirements. Standard models are available with clearance from 3' to 15' and with a reduction ratio from 1:3 to 1:1000. For assembly of non-standard planetary gear, contact our offices.



> Simple shaft version

Simple shaft type AS

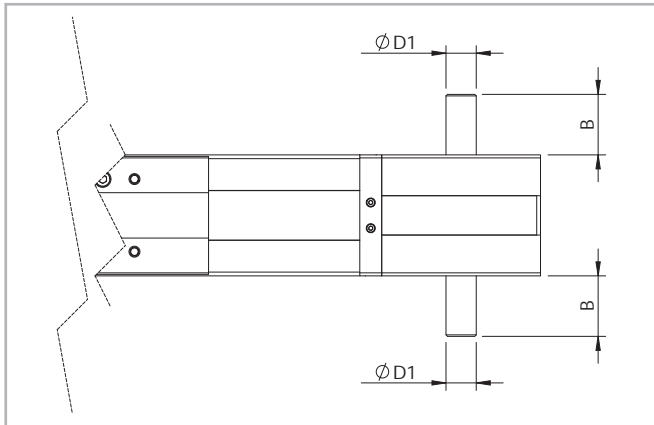

Fig. 10

Unit	Shaft type	B	D1
ELM 50	AS 12	25	12h7
ELM 65	AS 15	35	15h7
ELM 80	AS 20	40	20h7
ELM 110	AS 25	50	25h7

Tab. 21

Position of the simple shaft can be to the right, left, or both sides of the drive head.

Unit	Shaft type	Head code AS left	Head code AS right	Head code double AS
ELM 50	AS 12	1E	1C	1A
ELM 65	AS 15	1E	1C	1A
ELM 80	AS 20	1E	1C	1A
ELM 110	AS 25	1E	1C	1A

Tab. 22

Simple shaft type AE 10 for encoder assembly + AS

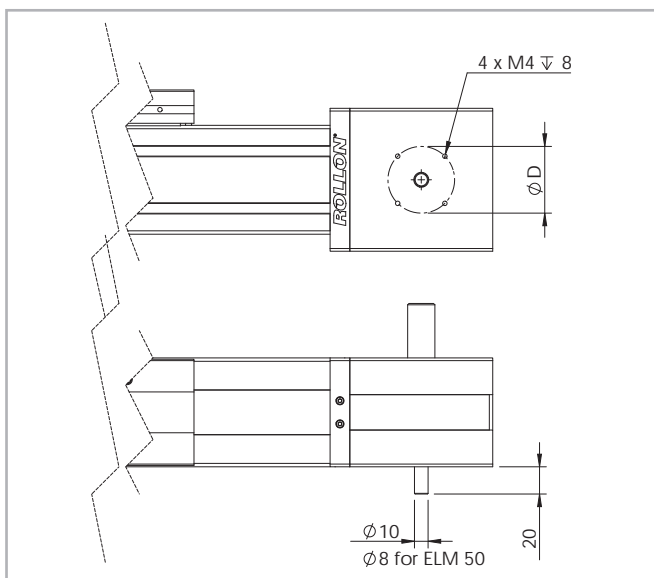

Fig. 11

Unit	Head code AS right + AE	Head code AS left + AE	$\varnothing D$
ELM 50	VF	VG	49
ELM 65	1G	1I	49
ELM 80	1G	1I	49
ELM 110	1G	1I	76

Tab. 23

Position of the simple shafts for encoder assembly to the right or to the left on the drive head.

Shaft with centering pilot

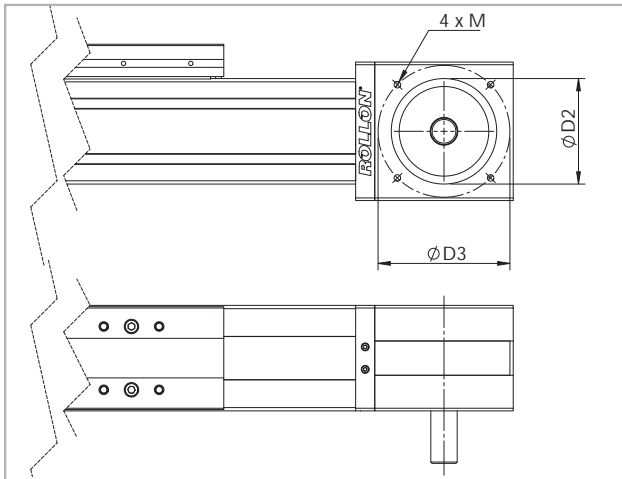

Fig. 12

Unit	Shaft type	D2	D3	M	Head code AS left	Head code AS right
ELM 50	AS 12	55	70	M5	VQ	VP
ELM 65	AS 15	60	85	M6	UQ	UP
ELM 80	AS 20	80	100	M8	UN	UM
ELM 110	AS 25	110	130	M8	UL	UI

Tab. 24

Rollon can provide driving heads with output shaft, centering diameter and threads.

Air Hole

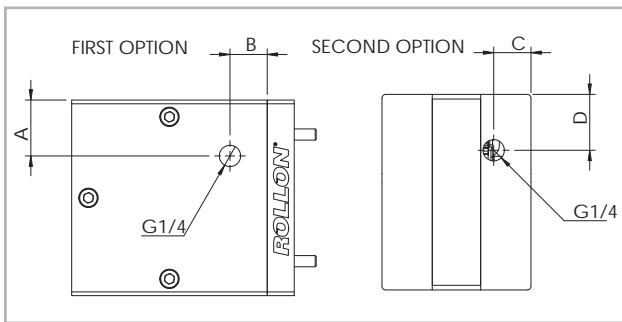

Fig. 13

Unit	First		Second	
	A	B	C	D
ELM 50	20	10	14	20
ELM 65	20	11	14	20
ELM 80	30	20	20	30
ELM 110	45	20,5	33	30

Tab. 25

> Hollow shafts

AC hollow shaft type

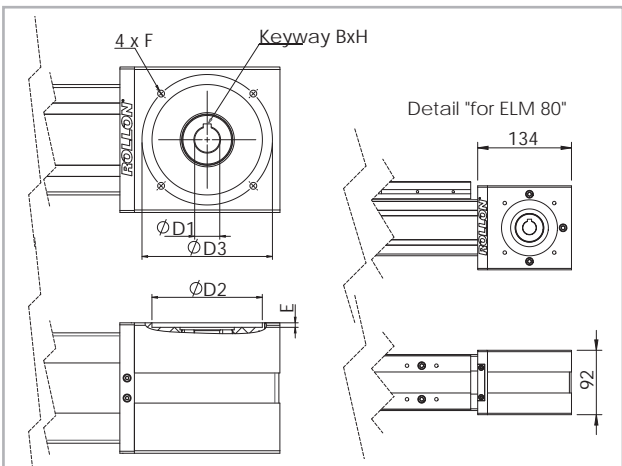

Fig. 14

Applicable to unit	Shaft type	Head code
ELM 50	AC 12	2A
ELM 80	AC 19	2A
ELM 110	AC 25	2A
ELM 110	AC 32	2C

Tab. 26

An (optional) connection flange is required to fit the standard reduction units selected by Rollon. For further information contact our offices

Dimensions (mm)

Applicable to unit	Shaft type	D1	D2	D3	E	F	Keyway B x H
ELM 50	AC 12	12H7	60	75	3.5	M5	4 x 4
ELM 80*	AC 19	19H7	80	100	3.5	M6	6 x 6
ELM 110	AC 25	25H7	110	130	4.5	M8	8 x 7
ELM 110	AC 32	32H7	130	165	4.5	M10	10 x 8

* Dimensions of head change (see detail "A" Fig. 14)

Tab. 27

> Linear units in parallel

Synchronization kit for use of ELM linear units in parallel

When movement consisting of two linear units in parallel is essential, a synchronization kit must be used. This consists of original Rollon lamina type precision joints complete with tapered splines and hollow aluminum drive shafts.

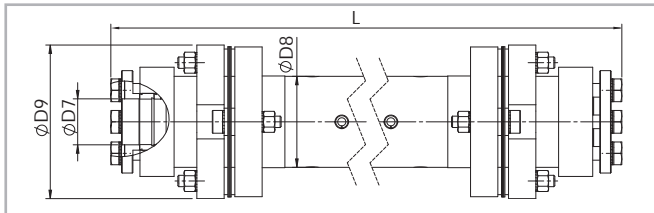

Fig. 15

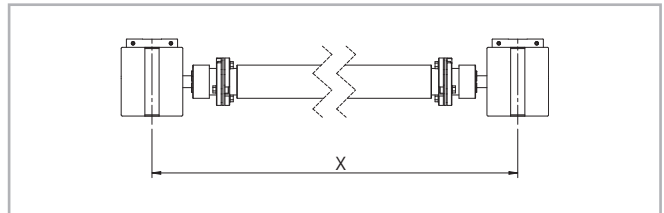

Fig. 16

Dimensions (mm)

Applicable to unit	Shaft type	D7	D8	D9	Code	Formula for length calculation
ELM 50	AP 12	12	25	45	GK12P...1A	$L = X - 68$ [mm]
ELM 65	AP 15	15	40	69.5	GK15P...1A	$L = X - 74$ [mm]
ELM 80	AP 20	20	40	69.5	GK20P...1A	$L = X - 97$ [mm]
ELM 110	AP 25	25	70	99	GK25P...1A	$L = X - 165$ [mm]

Tab. 28

> Accessories

Fixing by brackets

The linear motion systems used for the Rollon series ELM linear units enables them to support loads in any direction. They can therefore be installed in any position.

To install the units, we recommend the use of the dedicated T-slots in the extruded bodies as shown below.

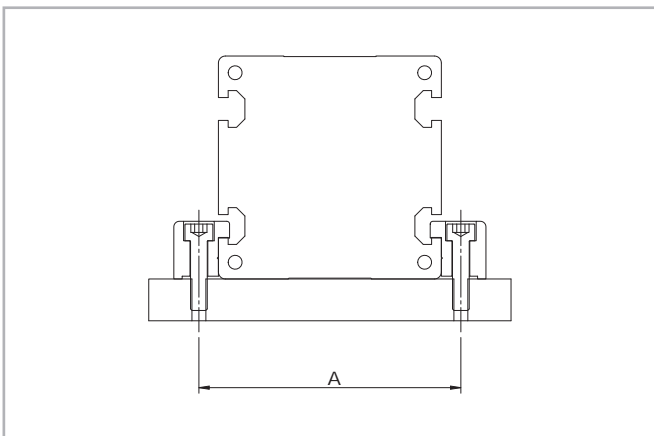

Fig. 17

Unit	A (mm)
ELM 50	62
ELM 65	77
ELM 80	94
ELM 110	130

Tab. 29

Warning:

Do not fix the linear units through the drive ends.

Fixing brackets

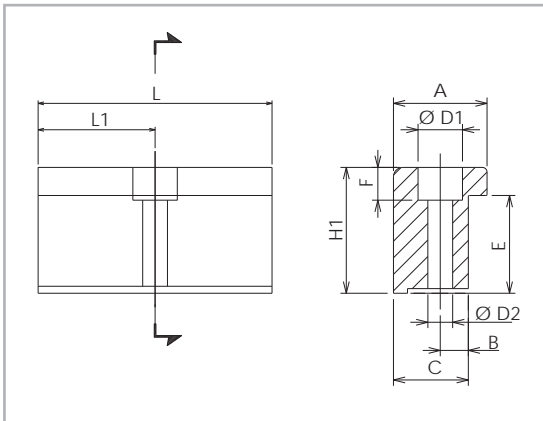

Fig. 18

Dimensions (mm)

Unit	A	H1	B	C	E	F	D1	D2	L	L1	Code
ELM 50	20	14	6	16	10	6	10	5.5	35	17.5	1000958
ELM 65	20	17.5	6	16	11.5	6	9.4	5.3	50	25	1001490
ELM 80	20	20.7	7	16	14.7	7	11	6.4	50	25	1001491
ELM 110	36.5	28.5	10	31	18.5	11.5	16.5	10.5	100	50	1001233

Tab. 30

Fixing bracket

Anodized aluminum block for fixing the linear units through the side T-slots of the body.

T-Nuts

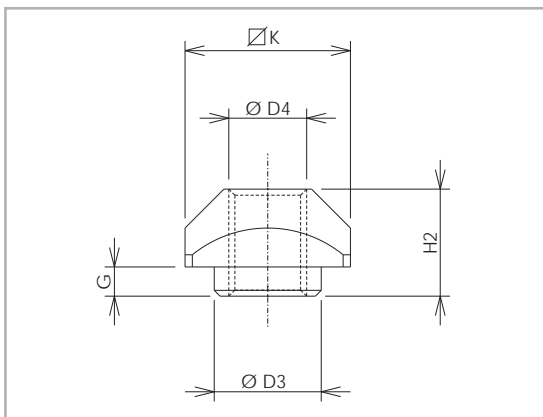

Fig. 19

Dimensions (mm)

Unit	D3	D4	G	H2	K	Code
ELM 50	-	M4	-	3.4	8	1001046
ELM 65	6.7	M5	2.3	6.5	10	1000627
ELM 80	8	M6	3.3	8.3	13	1000043
ELM 110	11	M8	2.8	10.8	17	1000932

Tab. 31

T-nuts

Steel nuts to be used in the T-slots of the body.

Proximity ELM...SP - ELM...CI series

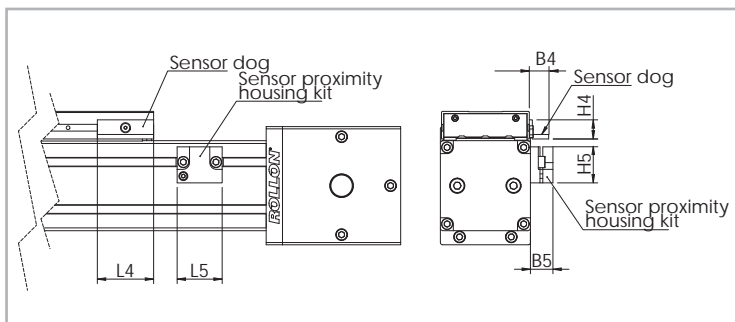

Fig. 20

Sensor proximity housing kit

Red anodized aluminum sensor holder, equipped with T-nuts for fixing onto the profile.

Sensor dog

L-shaped bracket in zinc-plated iron, mounted on the carriage and used for proximity switch operations.

Dimensions (mm)

Unit	B4	B5	L4	L5	H4	H5	For proximity	Sensor dog code	Sensor proximity housing kit code
ELM 50	9.5	14	25	29	11.9	22.5	Ø 8	G000268	G000211
ELM 65	17.2	20	50	40	17	32	Ø 12	G000267	G000212
ELM 80	17.2	20	50	40	17	32	Ø 12	G000267	G000209
ELM 110	17.2	20	50	40	17	32	Ø 12	G000267	G000210

Tab. 32

Ordering key

> Identification codes for the ELM linear unit

E	06 05=50 06=65 08=80 11=110	1C	2000	1A 1A=SP 1C=CI	D	
						Multiple carriage
						Linear motion system <i>see pg. PLS-4</i>
						L = total length of the unit
						Driving head code <i>see pg. PLS-10 - PLS-11</i>
						Linear unit size <i>see from pg. PLS-5 to pg. PLS-8</i>
						ELM Series <i>see pg. PLS-2</i>

In order to create identification codes for Actuator Line, you can visit: <http://configureactuator.rollon.com>

ROBOT series



> ROBOT series description

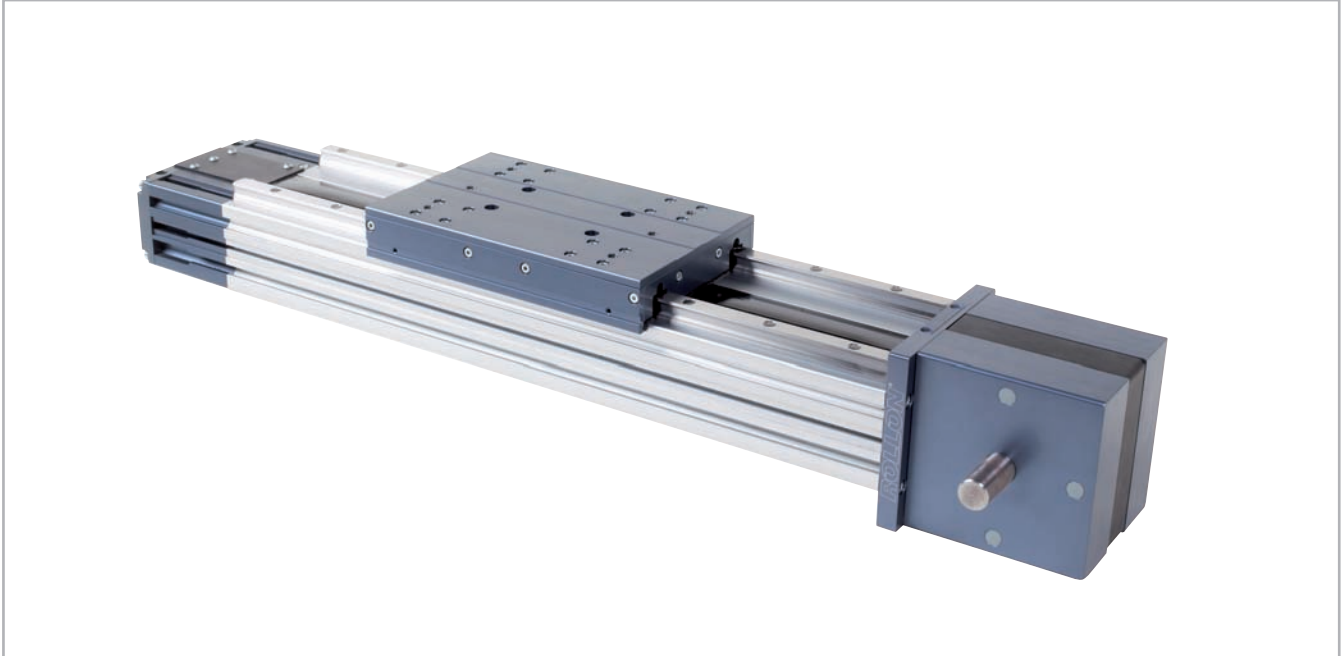

Fig. 21

ROBOT

The ROBOT series is particularly well-suited for heavy load applications where significant carriage pitch, yaw or roll moments are applied; or for the linear conveyance of SCARA-type articulated arm robots on a transfer or factory automation line. As a robust, high load choice, the ROBOT Series is the linear actuator for the most demanding applications.

Available in four sizes from 100 mm to 220 mm, the ROBOT series linear units have a rigid structure made by a heavy rectangular cross-section of extruded and anodized aluminum. The thrust force is transmitted by a steel reinforced polyurethane. The carriage is running on two parallel linear guides with four self-lubricated "maintenance-free" caged ball bearing blocks, positioned to support the carriage and all incident loads and moments. Multiple independent or idler style carriages are available to further enhance load or moment carrying capacity.

A polyurethane sealing strip ensures complete protection of the driving belt against dirt, chips, liquids and other contaminants.

The ROBOT series is the clear choice for heavy, high-speed, fluctuating load and moment applications in aggressive environments where repeatable, maintenance-free industrial automation is required.

For every size of ROBOT series is available also the 2C version, with 2 independent carriages. Each carriage is driven by its own belt. The driving head can accommodate two gearboxes, one on each side. This solution is ideal for pick & place application or loading and unloading machine.

Corrosion resistant version

All Plus System series of linear actuators are available with stainless steel elements, for applications in harsh environments and/or subject to frequent washes.

The Plus System linear units are constructed using extruded anodized 6060 and 6082 Anti-Corrosive Aluminum, which houses bearings, linear rails, nuts and bolts and components made of stainless steel, preventing or delaying corrosion caused by humidity experienced in the environments where the linear units are used.

Special no-deposit surface treatments are combined with a food grade lubrication system to allow use in highly sensitive applications, such as the food and pharmaceutical industries where product contamination is prohibited.

- Internal stainless steel elements
- Anodized 6060 and 6082 Anti-Corrosive Aluminum Profile
- AISI 440 stainless steel linear rails
- Lubricated with organic food grade vegetable oils

> The components

Extruded profile

The anodized 6060 aluminum alloy extrusion used for the profile of the Rollon ROBOT series linear units were designed and manufactured by industry experts to optimize weight while maintaining mechanical strength. The dimensional tolerances comply with EN 755-9 standards. T-slots are provided in the side and bottom faces to facilitate mounting.

Driving belt

The Rollon ROBOT series linear units use steel reinforced polyurethane drive belts with AT pitch. This belt is ideal due to its high load transmission characteristics, compact size and low noise. Used in conjunction with backlash-free pulleys, smooth alternating motion can be achieved. Optimization of the maximum belt width/body dimension ratio enables the following performance characteristics to be achieved:

- **High speed**
- **Low noise**
- **Low wear**

The provision of guidance for the belt within the body causes it to run central on the pulley, there by ensuring long service life.

Carriage

The carriage of the Rollon ROBOT series linear units are made entirely of anodized aluminum. Each carriage has mounting holes fitted with stainless steel thread inserts. Rollon offers multiple carriages to accommodate a vast array of applications. The unique design of the carriage allows for the sealing strip to pass through the carriage as well as house brush seals to remove contaminants from the sealing strip.

Sealing strip

Rollon ROBOT series linear units are equipped with a polyurethane sealing strip to protect all of the internal components from dust, contaminants, and other foreign objects. The sealing strip runs the length of the body and is kept in position by micro-bearings located within the carriage. This minimizes frictional resistance as the strip passes through the carriage while providing maximum protection.

General data about aluminum used: AL 6060

Chemical composition [%]

Al	Mg	Si	Fe	Mn	Zn	Cu	Impurities
Remainder	0.35-0.60	0.30-0.60	0.30	0.10	0.10	0.10	0.05-0.15

Tab. 33

Physical characteristics

Density	Coeff. of elasticity	Coeff. of thermal expansion (20°-100°C)	Thermal conductivity (20°C)	Specific heat (0°-100°C)	Resistivity	Melting point
$\frac{\text{kg}}{\text{dm}^3}$	$\frac{\text{kN}}{\text{mm}^2}$	$\frac{10^{-6}}{\text{K}}$	$\frac{\text{W}}{\text{m} \cdot \text{K}}$	$\frac{\text{J}}{\text{kg} \cdot \text{K}}$	$\Omega \cdot \text{m} \cdot 10^{-9}$	°C
2.7	69	23	200	880-900	33	600-655

Tab. 34

Mechanical characteristics

Rm	Rp (02)	A	HB
$\frac{\text{N}}{\text{mm}^2}$	$\frac{\text{N}}{\text{mm}^2}$	%	—
205	165	10	60-80

Tab. 35

> The linear motion system

The linear motion system has been designed to meet the load capacity, speed, and maximum acceleration conditions of a wide variety of applications. Two linear motion systems are offered:

ROBOT ...SP with ball bearing guides

- Two ball bearing guides with high load capacity are mounted in two dedicated seats on the outer sides of the body.
- The carriage is assembled on four pre-loaded ball bearing blocks.
- The four ball row configuration enable the carriage to withstand loading in the four main directions.
- The four blocks have seals on both sides and, if necessary, an additional scraper can be fitted for very dusty conditions.
- The ball bearing carriages of the SP versions are also fitted with a retention cage that eliminates "steel-steel" contact between adjacent revolving parts and prevents misalignment.
- The lubrication reservoirs (pockets) fitted on the cages considerably decreases re-lubrication frequency. Lubrication reservoirs (pockets) installed on the front of the ball bearing blocks supply the right amount of grease, thus promoting long maintenance interval.

The linear motion system described above offers:

- High speed and acceleration
- High load capacity
- High bending permissible moments
- Low friction
- Long duration
- Maintenance free (dependent on application, see page PLS-32 "Lubrication")
- Low noise

ROBOT SP section

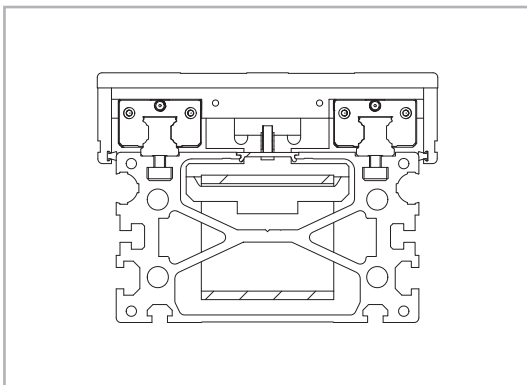

Fig. 22

ROBOT CE with gothic arch bearing guides

- Two hardened steel rods (58/60 HRC hardness, tolerance: h6) are securely inserted into the aluminum body.
- The carriage is fitted with six bearing assemblies (except for ROBOT 160), each having a gothic arch groove machined into its outer race to run on the steel rods.
- The six bearings (except for ROBOT 160) are mounted on steel pins, of which are eccentric to allow the running clearance and preload to be set.
- To keep the running tracks clean and lubricated, four grease impregnated felt seals, complete with grease reservoirs, are fitted at the ends.

The linear motion system described above offers:

- Good positioning accuracy
- Low noise
- Maintenance free (dependant on application)

ROBOT CE section

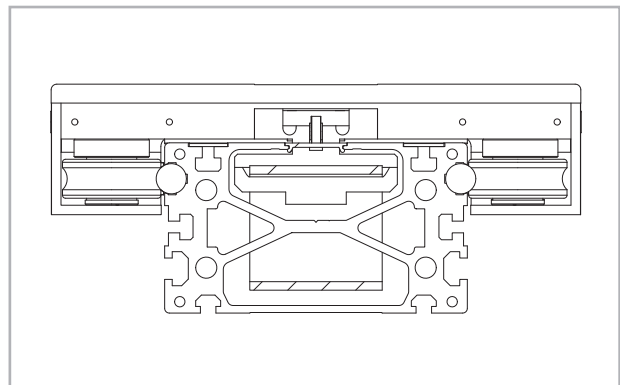

Fig. 23

ROBOT 2C

For both the SP and CE linear motion system is available the 2C version, which features 2 independent carriages on a single actuator.

> ROBOT 100 SP

ROBOT 100 SP dimensions

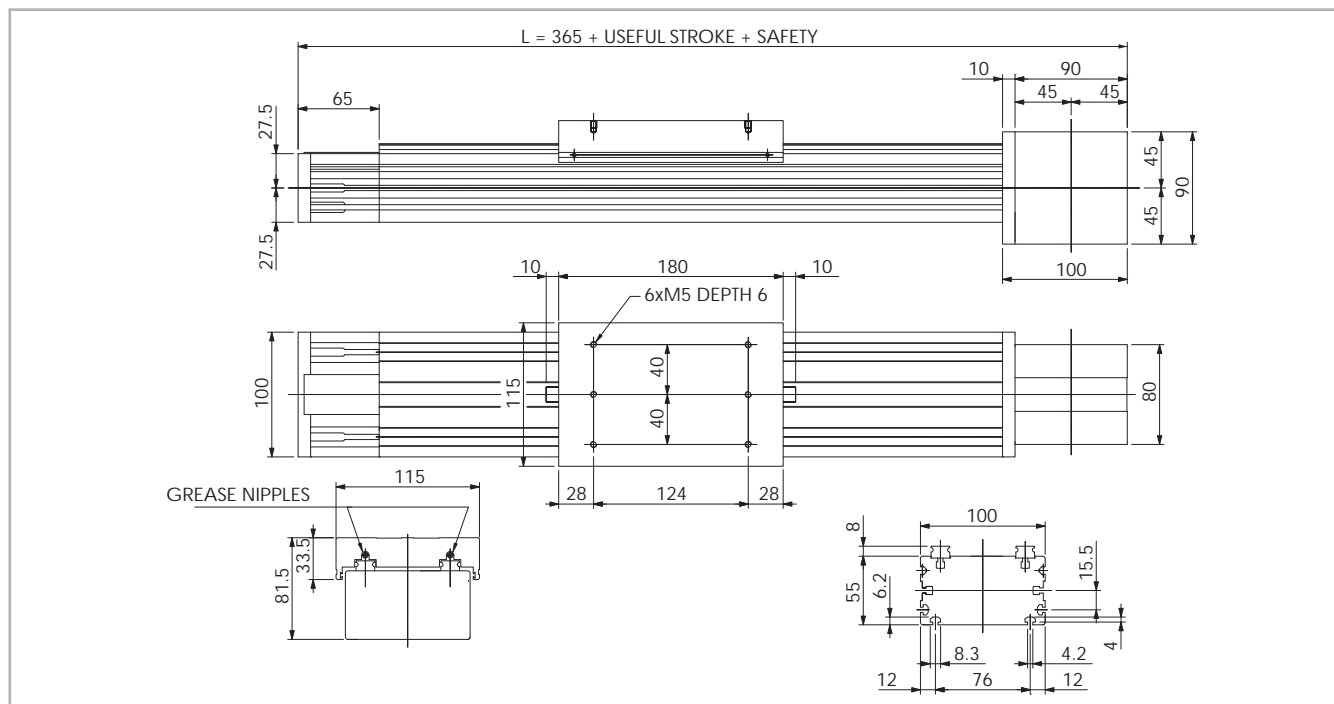

* The length of the safety stroke is provided on request according to the customer's specific requirements.

Fig. 24

Technical data

	Type
	ROBOT 100 SP
Max. useful stroke length [mm]	5800
Max. positioning repeatability [mm]*1	± 0.05
Max. speed [m/s]	4.0
Max. acceleration [m/s ²]	50
Type of belt	32 AT 5
Type of pulley	Z 23
Pulley pitch diameter [mm]	36.61
Carriage displacement per pulley turn [mm]	115
Carriage weight [kg]	2.4
Zero travel weight [kg]	4.5
Weight for 100 mm useful stroke [kg]	0.8
Starting torque [Nm]	1.3
Moment of inertia of pulleys [g mm ²]	87200

*1) Positioning repeatability is dependent on the type of transmission used

Tab. 36

ROBOT 100 SP - Load capacity

Type	F _x [N]		F _y [N]		F _z [N]		M _x [Nm]		M _y [Nm]		M _z [Nm]	
	Stat.	Dyn.	Stat.	Dyn.	Stat.	Dyn.	Stat.	Dyn.	Stat.	Dyn.	Stat.	Dyn.
ROBOT 100 SP	1176	739	25040	16800	25040	16800	851	571	1452	974	1452	974

See verification under static load and lifetime on page SL-2 and SL-3

Tab. 39

Moments of inertia of the aluminum body

Type	I _x [10 ⁷ mm ⁴]	I _y [10 ⁷ mm ⁴]	I _p [10 ⁷ mm ⁴]
ROBOT 100	0.05	0.23	0.28

Tab. 37

Driving belt

The driving belt is manufactured from a friction resistant polyurethane and with steel cords for high tensile stress resistance.

Type	Type of belt	Belt width [mm]	Weight kg/m
ROBOT 100 SP	32 AT 5	32	0.105

Tab. 38

Belt length (mm) = 2 x L - 115

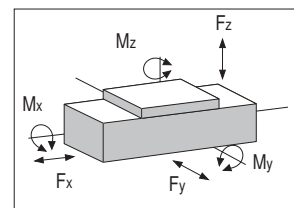

> ROBOT 100 SP-2C DOUBLE INDEPENDENT CARRIAGES

ROBOT 100 SP-2C dimensions

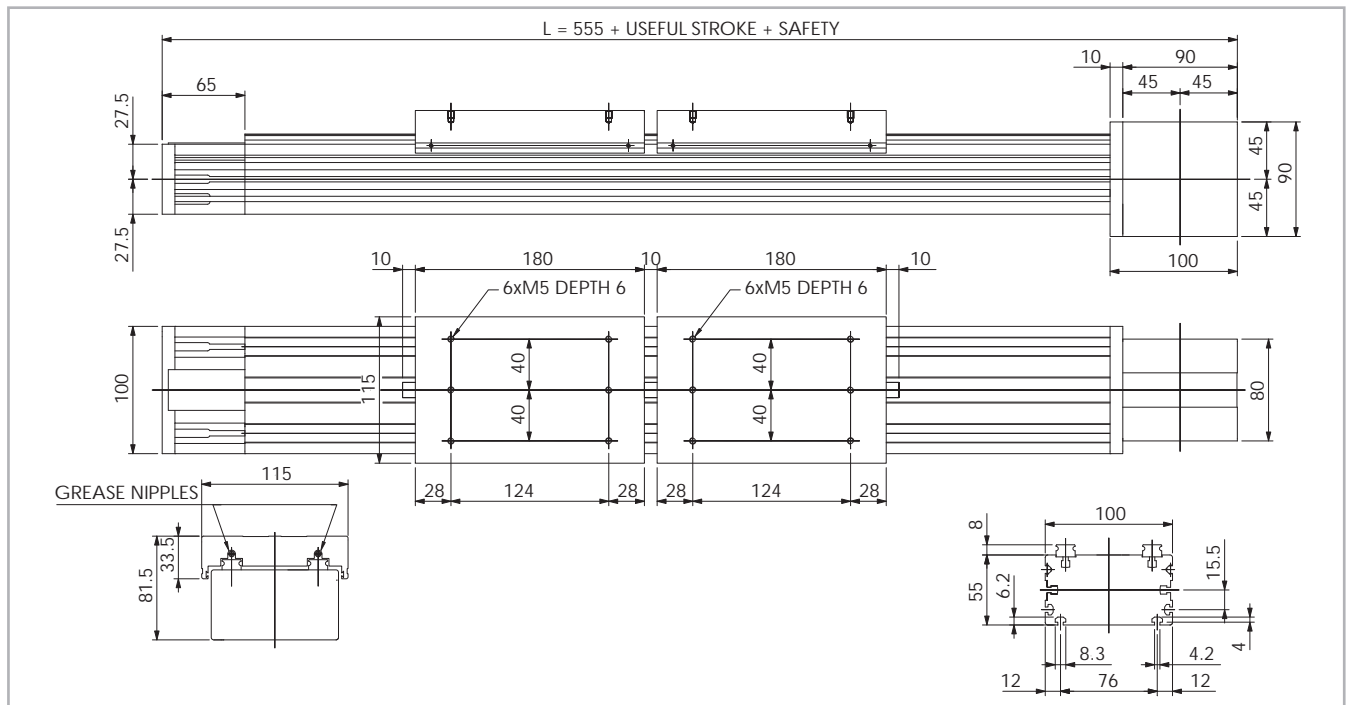

* The length of the safety stroke is provided on request according to the customer's specific requirements.

Fig. 25

Technical data

	Type
	ROBOT 100 SP-2C
Max. useful stroke length [mm]	5600
Max. positioning repeatability [mm]*1	± 0.05
Max. speed [m/s]	4.0
Max. acceleration [m/s ²]	50
Type of belt	16 AT 5
Type of pulley	Z 23
Pulley pitch diameter [mm]	36.61
Carriage displacement per pulley turn [mm]	115
Carriage weight [kg]	2.4
Zero travel weight [kg]	8.0
Weight for 100 mm useful stroke [kg]	0.8
Starting torque [Nm]	1.3
Moment of inertia of pulleys [g mm ²]	16220

*1) Positioning repeatability is dependent on the type of transmission used

Tab. 40

ROBOT 100 SP-2C - Load capacity

Type	F _x [N]		F _y [N]		F _z [N]		M _x [Nm]		M _y [Nm]		M _z [Nm]	
	Stat.	Dyn.	Stat.	Dyn.	Stat.	Dyn.	Stat.	Dyn.	Stat.	Dyn.	Stat.	Dyn.
ROBOT 100 SP-2C	588	370	25040	16800	25040	16800	851	571	1452	974	1452	974

See verification under static load and lifetime on page SL-2 and SL-3

Tab. 43

Moments of inertia of the aluminum body

Type	I _x [10 ⁷ mm ⁴]	I _y [10 ⁷ mm ⁴]	I _p [10 ⁷ mm ⁴]
ROBOT 100	0.05	0.23	0.28

Tab. 41

Driving belt

The driving belt is manufactured from a friction resistant polyurethane and with steel cords for high tensile stress resistance.

Type	Type of belt	Belt width [mm]	Weight kg/m
ROBOT 100 SP-2C	16 AT 5	16	0.05

Tab. 42

Belt length (mm) = 2 x L - 115

Two belts for each actuator.

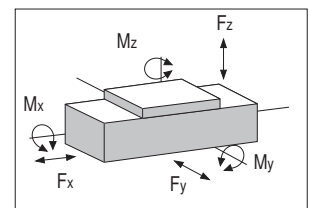

> ROBOT 100 CE

ROBOT 100 CE dimensions

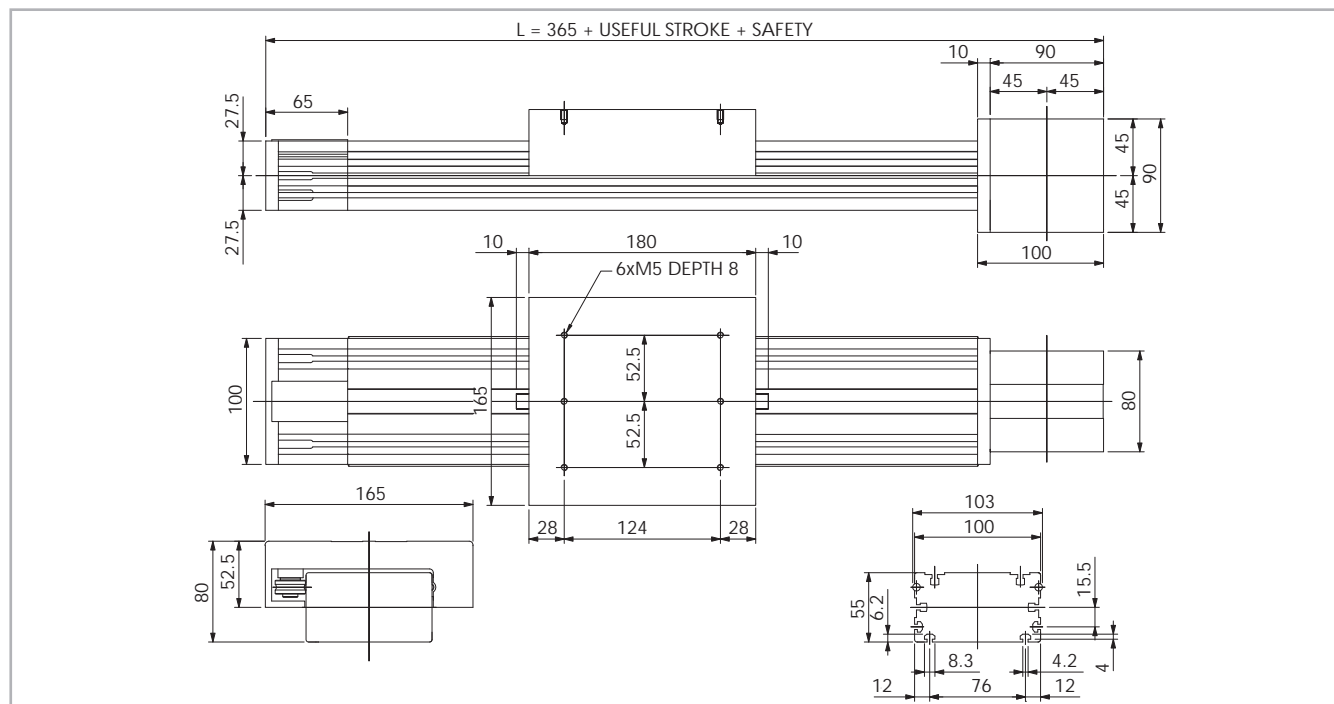

* The length of the safety stroke is provided on request according to the customer's specific requirements.

Fig. 26

Technical data

	Type
	ROBOT 100 CE
Max. useful stroke length [mm]	6000
Max. positioning repeatability [mm]*1	± 0.05
Max. speed [m/s]	1.5
Max. acceleration [m/s ²]	1.5
Type of belt	32 AT 5
Type of pulley	Z 23
Pulley pitch diameter [mm]	36.61
Carriage displacement per pulley turn [mm]	115
Carriage weight [kg]	3.4
Zero travel weight [kg]	5.5
Weight for 100 mm useful stroke [kg]	0.8
Starting torque [Nm]	1.3
Moment of inertia of pulleys [g mm ²]	87200

*1) Positioning repeatability is dependent on the type of transmission used

Tab. 44

ROBOT 100 CE - Load capacity

Type	F _x [N]		F _y [N]		F _z [N]		M _x [Nm]		M _y [Nm]		M _z [Nm]	
	Stat.	Dyn.	Stat.	Dyn.	Stat.	Dyn.	Stat.	Dyn.	Stat.	Dyn.	Stat.	Dyn.
ROBOT 100 CE	1176	907	3800	7340	2460	4080	120	198	160	265	250	477

See verification under static load and lifetime on page SL-2 and SL-3

Tab. 47

Moments of inertia of the aluminum body

Type	I _x [10 ⁷ mm ⁴]	I _y [10 ⁷ mm ⁴]	I _p [10 ⁷ mm ⁴]
ROBOT 100	0.05	0.23	0.28

Tab. 45

Driving belt

The driving belt is manufactured from a friction resistant polyurethane and with steel cords for high tensile stress resistance.

Type	Type of belt	Belt width [mm]	Weight kg/m
ROBOT 100-CE	32 AT 5	32	0.105

Tab. 46

Belt length (mm) = 2 x L - 115

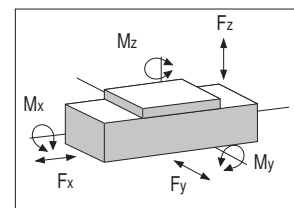

> ROBOT 100 CE-2C DOUBLE INDEPENDENT CARRIAGES

ROBOT 100 CE-2C dimensions

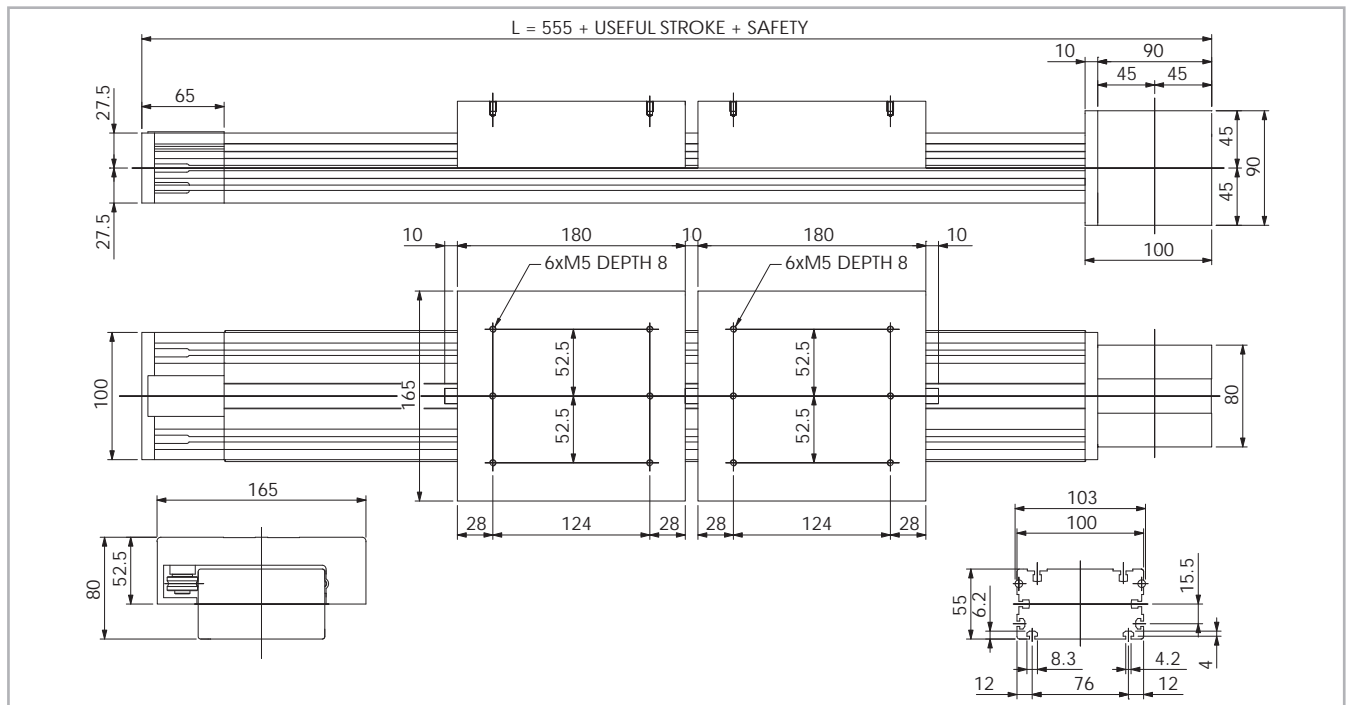

* The length of the safety stroke is provided on request according to the customer's specific requirements.

Fig. 27

Technical data

	Type
	ROBOT 100 CE-2C
Max. useful stroke length [mm]	5800
Max. positioning repeatability [mm]*1	± 0.05
Max. speed [m/s]	1.5
Max. acceleration [m/s ²]	1.5
Type of belt	16 AT 5
Type of pulley	Z 23
Pulley pitch diameter [mm]	36.61
Carriage displacement per pulley turn [mm]	115
Carriage weight [kg]	3.4
Zero travel weight [kg]	10.5
Weight for 100 mm useful stroke [kg]	0.8
Starting torque [Nm]	1.3
Moment of inertia of pulleys [g mm ²]	16220

*1) Positioning repeatability is dependent on the type of transmission used

Tab. 48

ROBOT 100 CE-2C - Load capacity

Type	F _x [N]		F _y [N]		F _z [N]		M _x [Nm]		M _y [Nm]		M _z [Nm]	
	Stat.	Dyn.	Stat.	Dyn.	Stat.	Dyn.	Stat.	Dyn.	Stat.	Dyn.	Stat.	Dyn.
ROBOT 100 CE-2C	588	454	3800	7340	2460	4080	120	198	160	265	250	477

See verification under static load and lifetime on page SL-2 and SL-3

Tab. 51

Moments of inertia of the aluminum body

Type	I _x [10 ⁷ mm ⁴]	I _y [10 ⁷ mm ⁴]	I _p [10 ⁷ mm ⁴]
ROBOT 100	0.05	0.23	0.28

Tab. 49

Driving belt

The driving belt is manufactured from a friction resistant polyurethane and with steel cords for high tensile stress resistance.

Type	Type of belt	Belt width [mm]	Weight kg/m
ROBOT 100 CE-2C	16 AT 5	16	0.05

Tab. 50

Belt length (mm) = 2 x L - 115

Two belts for each actuator.

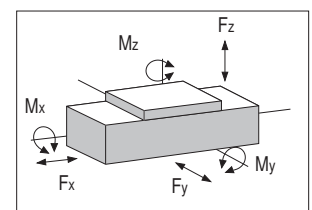

ROBOT 130 SP

ROBOT 130 SP dimensions

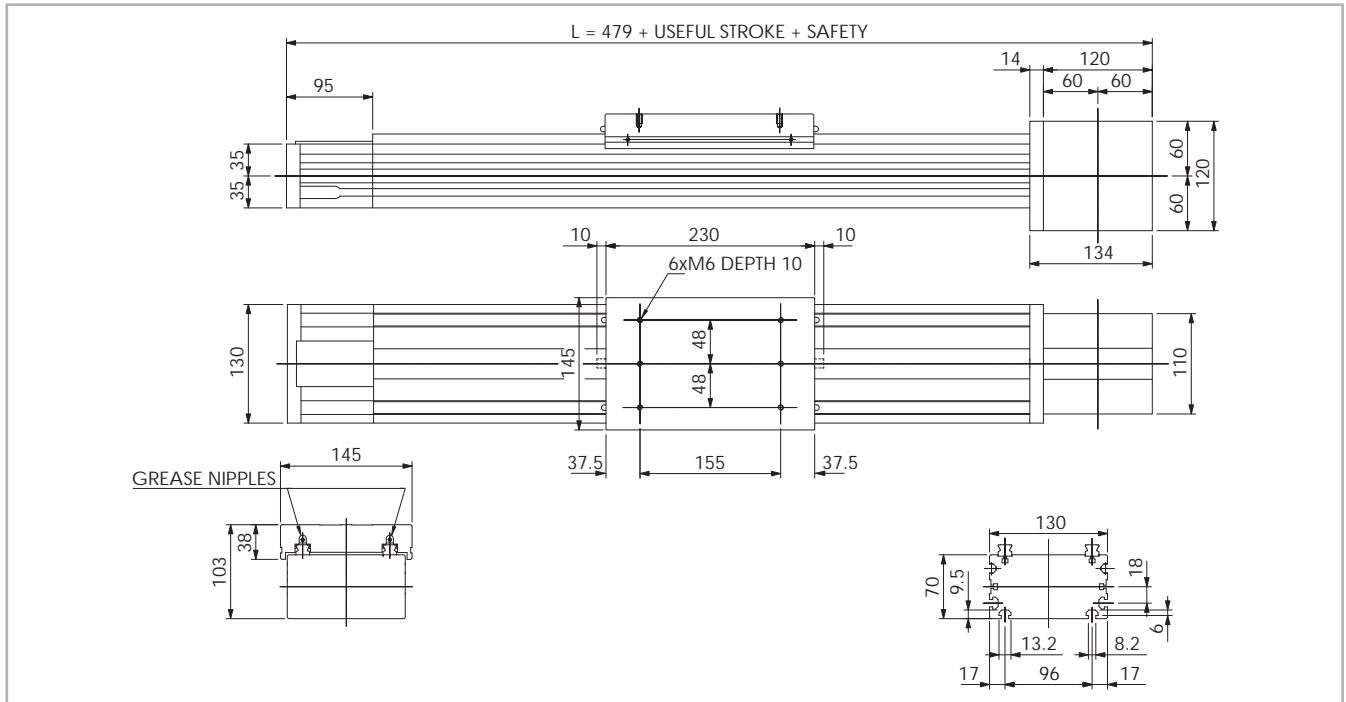

* The length of the safety stroke is provided on request according to the customer's specific requirements.

Fig. 28

Technical data

	Type
	ROBOT 130 SP
Max. useful stroke length [mm]*1	6000
Max. positioning repeatability [mm]*2	± 0.05
Max. speed [m/s]	5.0
Max. acceleration [m/s ²]	50
Type of belt	50 AT 10
Type of pulley	Z 17
Pulley pitch diameter [mm]	54.11
Carriage displacement per pulley turn [mm]	170
Carriage weight [kg]	2.8
Zero travel weight [kg]	9.1
Weight for 100 mm useful stroke [kg]	1.2
Starting torque [Nm]	2.7
Moment of inertia of pulleys [g mm ²]	493200

Tab. 52

*1) It is possible to obtain strokes up to 11000 mm by means of special Rollon joints

*2) Positioning repeatability is dependent on the type of transmission used

ROBOT 130 SP - Load capacity

Type	F _x [N]		F _y [N]		F _z [N]		M _x [Nm]		M _y [Nm]		M _z [Nm]	
	Stat.	Dyn.	Stat.	Dyn.	Stat.	Dyn.	Stat.	Dyn.	Stat.	Dyn.	Stat.	Dyn.
ROBOT 130 SP	2775	1575	48400	29120	48400	29120	2323	1398	3170	1907	3170	1907

See verification under static load and lifetime on page SL-2 and SL-3

Tab. 55

Moments of inertia of the aluminum body

Type	I _x [10 ⁷ mm ⁴]	I _y [10 ⁷ mm ⁴]	I _p [10 ⁷ mm ⁴]
ROBOT 130	0.15	0.65	0.79

Tab. 53

Driving belt

The driving belt is manufactured from a friction resistant polyurethane and with steel cords for high tensile stress resistance.

Type	Type of belt	Belt width [mm]	Weight kg/m
ROBOT 130 SP	50 AT 10	50	0.29

Tab. 54

$$\text{Belt length (mm)} = 2 \times L - 103$$

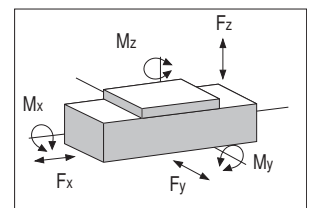

> ROBOT 130 SP-2C DOUBLE INDEPENDENT CARRIAGES

ROBOT 130 SP-2C dimensions

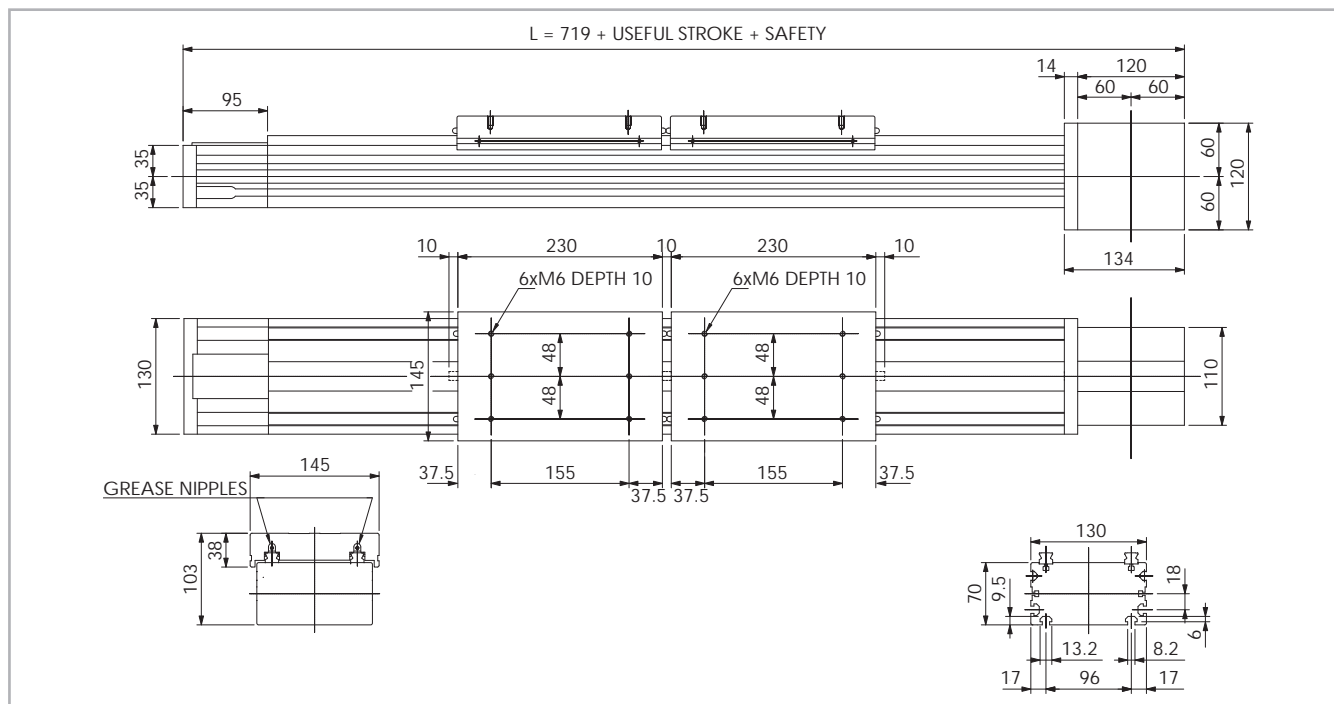

* The length of the safety stroke is provided on request according to the customer's specific requirements.

Fig. 29

Technical data

	Type
	ROBOT 130 SP-2C
Max. useful stroke length [mm]*1	6000
Max. positioning repeatability [mm]*2	± 0.05
Max. speed [m/s]	5.0
Max. acceleration [m/s ²]	50
Type of belt	25 AT 10
Type of pulley	Z 17
Pulley pitch diameter [mm]	54.11
Carriage displacement per pulley turn [mm]	170
Carriage weight [kg]	2.8
Zero travel weight [kg]	14.9
Weight for 100 mm useful stroke [kg]	1.2
Starting torque [Nm]	2.7
Moment of inertia of pulleys [g mm ²]	196200

*1) It is possible to obtain strokes up to 11000 mm by means of special Rollon joints

*2) Positioning repeatability is dependent on the type of transmission used

Tab. 56

ROBOT 130 SP-2C - Load capacity

Type	F _x [N]		F _y [N]		F _z [N]		M _x [Nm]		M _y [Nm]		M _z [Nm]	
	Stat.	Dyn.	Stat.	Dyn.	Stat.	Dyn.	Stat.	Dyn.	Stat.	Dyn.	Stat.	Dyn.
ROBOT 130 SP-2C	1388	788	48400	29120	48400	29120	2323	1398	3170	1907	3170	1907

See verification under static load and lifetime on page SL-2 and SL-3

Tab. 59

Moments of inertia of the aluminum body

Type	I _x [10 ⁷ mm ⁴]	I _y [10 ⁷ mm ⁴]	I _p [10 ⁷ mm ⁴]
ROBOT 130	0.15	0.65	0.79

Tab. 57

Driving belt

The driving belt is manufactured from a friction resistant polyurethane and with steel cords for high tensile stress resistance.

Type	Type of belt	Belt width [mm]	Weight kg/m
ROBOT 130 SP-2C	25 AT 10	25	0.16

Tab. 58

Belt length (mm) = 2 x L - 103

Two belts for each actuator.

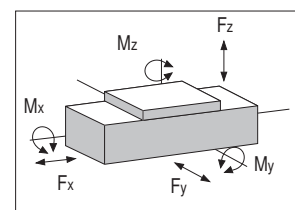

> ROBOT 130 CE

ROBOT 130 CE dimensions

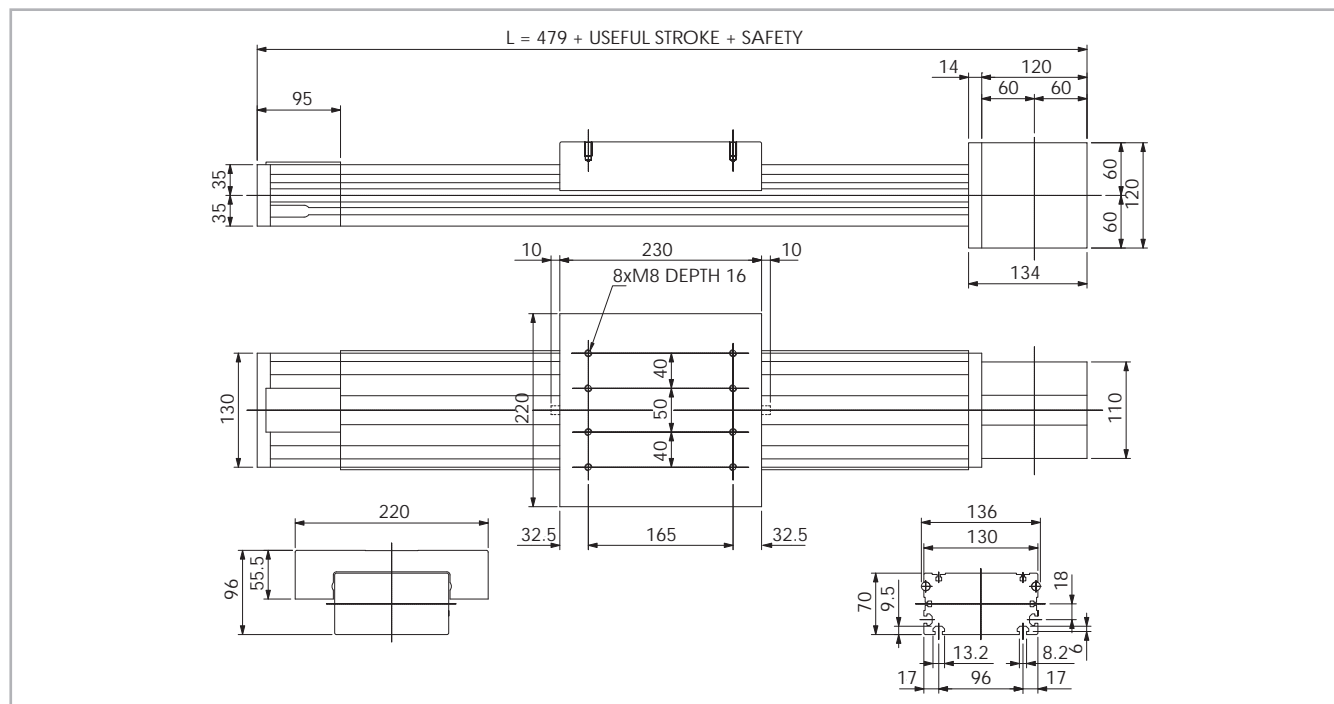

* The length of the safety stroke is provided on request according to the customer's specific requirements.

Fig. 30

Technical data

	Type
	ROBOT 130 CE
Max. useful stroke length [mm]*1	6000
Max. positioning repeatability [mm]*2	± 0.05
Max. speed [m/s]	1.5
Max. acceleration [m/s ²]	1.5
Type of belt	50 AT 10
Type of pulley	Z 17
Pulley pitch diameter [mm]	54.11
Carriage displacement per pulley turn [mm]	170
Carriage weight [kg]	4.3
Zero travel weight [kg]	10.3
Weight for 100 mm useful stroke [kg]	1.1
Starting torque [Nm]	2.7
Moment of inertia of pulleys [g mm ²]	493200

Tab. 60

*1) It is possible to obtain strokes up to 11000 mm by means of special Rollon joints

*2) Positioning repeatability is dependent on the type of transmission used

ROBOT 130 CE - Load capacity

Type	F _x [N]		F _y [N]		F _z [N]		M _x [Nm]		M _y [Nm]		M _z [Nm]	
	Stat.	Dyn.	Stat.	Dyn.	Stat.	Dyn.	Stat.	Dyn.	Stat.	Dyn.	Stat.	Dyn.
ROBOT 130 CE	2775	2138	3800	17000	4760	8700	300	548	392	724	704	1410

See verification under static load and lifetime on page SL-2 and SL-3

Tab. 63

Moments of inertia of the aluminum body

Type	I _x [10 ⁷ mm ⁴]	I _y [10 ⁷ mm ⁴]	I _p [10 ⁷ mm ⁴]
ROBOT 130	0.15	0.65	0.79

Tab. 61

Driving belt

The driving belt is manufactured from a friction resistant polyurethane and with steel cords for high tensile stress resistance.

Type	Type of belt	Belt width [mm]	Weight kg/m
ROBOT 130 CE	50 AT 10	50	0.29

Tab. 62

Belt length (mm) = 2 x L - 103

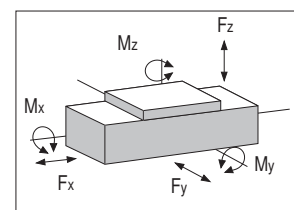

ROBOT 130 CE-2C DOUBLE INDEPENDENT CARRIAGES

ROBOT 130 CE-2C dimensions

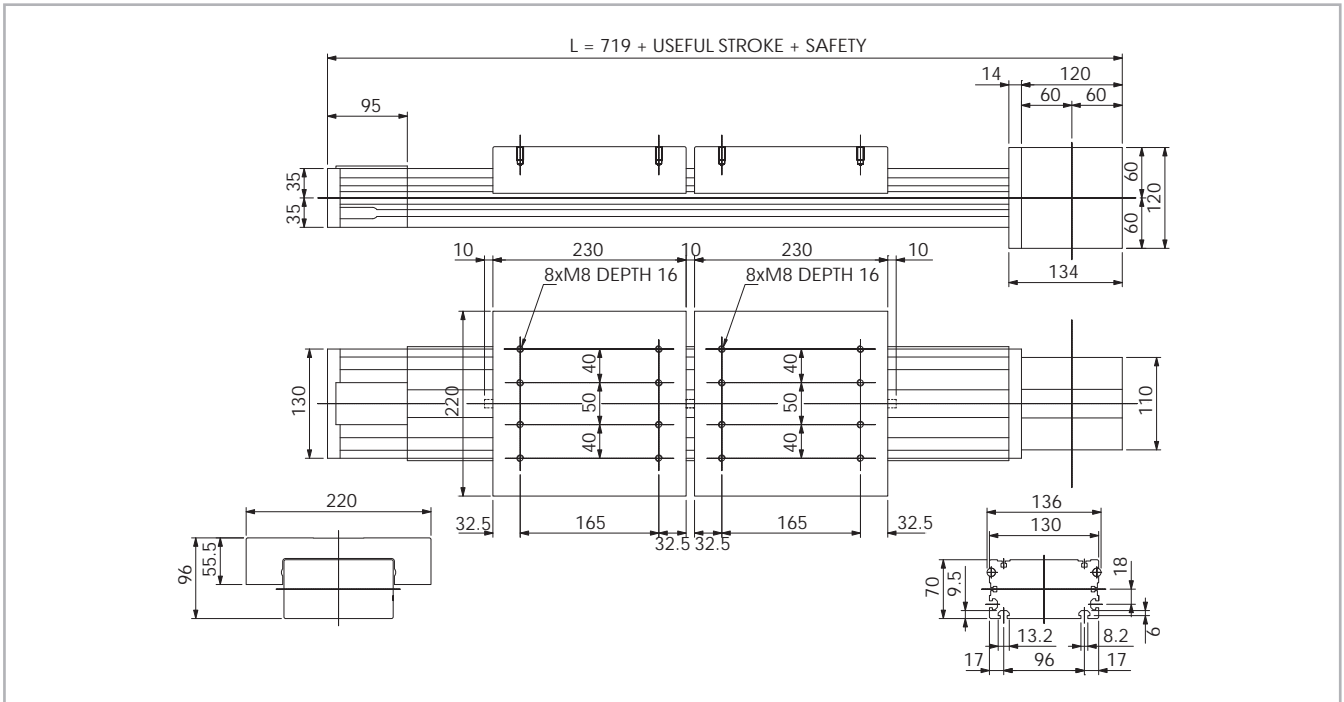

* The length of the safety stroke is provided on request according to the customer's specific requirements.

Fig. 31

Technical data

	Type
	ROBOT 130 CE-2C
Max. useful stroke length [mm]*1	6000
Max. positioning repeatability [mm]*2	± 0.05
Max. speed [m/s]	1.5
Max. acceleration [m/s ²]	1.5
Type of belt	25 AT 10
Type of pulley	Z 17
Pulley pitch diameter [mm]	54.11
Carriage displacement per pulley turn [mm]	170
Carriage weight [kg]	4.3
Zero travel weight [kg]	17.4
Weight for 100 mm useful stroke [kg]	1.1
Starting torque [Nm]	2.7
Moment of inertia of pulleys [g mm ²]	196200

*1) It is possible to obtain strokes up to 11000 mm by means of special Rollon joints

*2) Positioning repeatability is dependent on the type of transmission used

Tab. 64

ROBOT 130 CE-2C - Load capacity

Type	F _x [N]		F _y [N]		F _z [N]		M _x [Nm]		M _y [Nm]		M _z [Nm]	
	Stat.	Dyn.	Stat.	Dyn.	Stat.	Dyn.	Stat.	Dyn.	Stat.	Dyn.	Stat.	Dyn.
ROBOT 130 CE-2C	1388	1069	3800	17000	4760	8700	300	548	392	724	704	1410

See verification under static load and lifetime on page SL-2 and SL-3

Tab. 67

Moments of inertia of the aluminum body

Type	I _x [10 ⁷ mm ⁴]	I _y [10 ⁷ mm ⁴]	I _p [10 ⁷ mm ⁴]
ROBOT 130	0.15	0.65	0.79

Tab. 65

Driving belt

The driving belt is manufactured from a friction resistant polyurethane and with steel cords for high tensile stress resistance.

Type	Type of belt	Belt width [mm]	Weight kg/m
ROBOT 130 CE-2C	25 AT 10	25	0.16

Tab. 66

Belt length (mm) = 2 x L - 103

Two belts for each actuator.

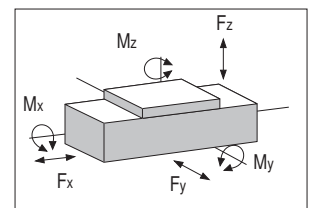

> ROBOT 160 SP

ROBOT 160 SP dimensions

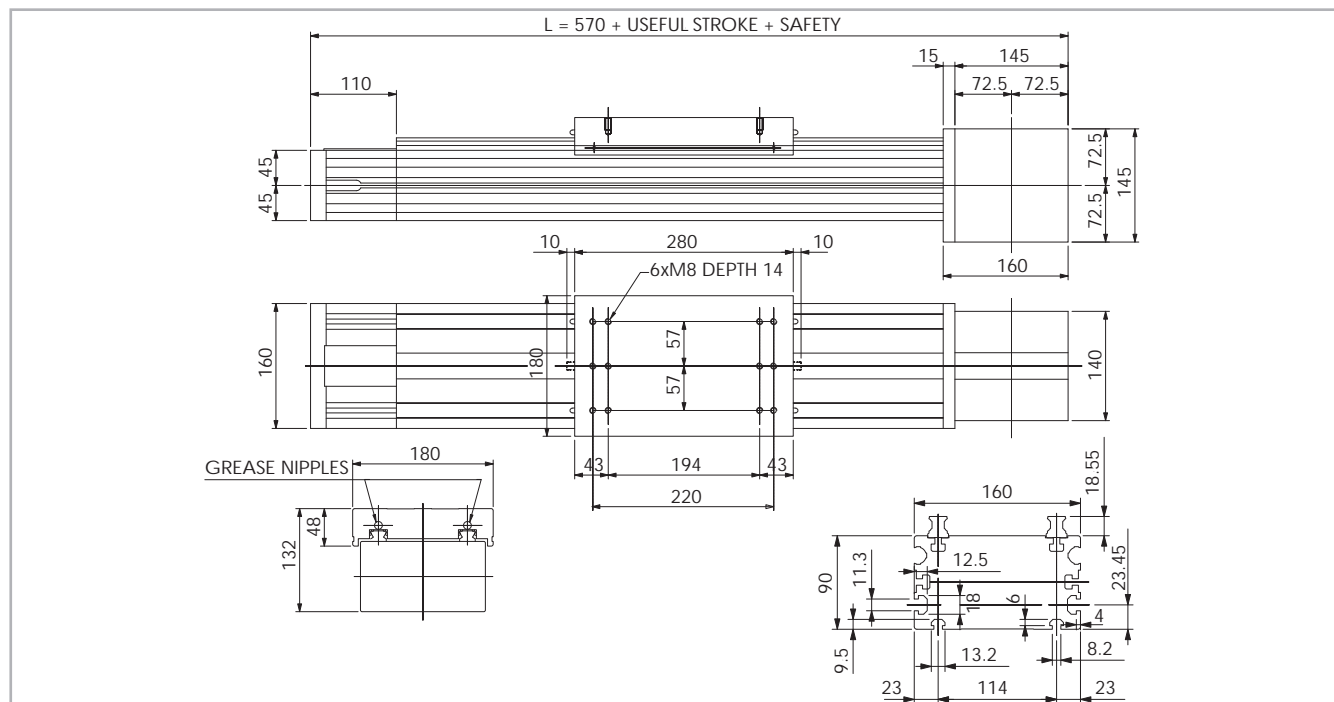

* The length of the safety stroke is provided on request according to the customer's specific requirements.

Fig. 32

Technical data

	Type
	ROBOT 160 SP
Max. useful stroke length [mm]*1	6000
Max. positioning repeatability [mm]*2	± 0.05
Max. speed [m/s]	5.0
Max. acceleration [m/s ²]	50
Type of belt	70 AT 10
Type of pulley	Z 20
Pulley pitch diameter [mm]	63.66
Carriage displacement per pulley turn [mm]	200
Carriage weight [kg]	5.3
Zero travel weight [kg]	21
Weight for 100 mm useful stroke [kg]	1.9
Starting torque [Nm]	4.5
Moment of inertia of pulleys [g mm ²]	1.202 · 10 ⁶

Tab. 68

*1) It is possible to obtain strokes up to 11000 mm by means of special Rollon joints

*2) Positioning repeatability is dependent on the type of transmission used

ROBOT 160 SP - Load capacity

Type	F _x [N]		F _y [N]		F _z [N]		M _x [Nm]		M _y [Nm]		M _z [Nm]	
	Stat.	Dyn.	Stat.	Dyn.	Stat.	Dyn.	Stat.	Dyn.	Stat.	Dyn.	Stat.	Dyn.
ROBOT 160 SP	4662	2772	86800	69600	86800	69600	4935	3957	6901	5533	6901	5533

See verification under static load and lifetime on page SL-2 and SL-3

Tab. 71

Moments of inertia of the aluminum body

Type	I _x [10 ⁷ mm ⁴]	I _y [10 ⁷ mm ⁴]	I _p [10 ⁷ mm ⁴]
ROBOT 160	0.37	1.51	1.88

Tab. 69

Driving belt

The driving belt is manufactured from a friction resistant polyurethane and with steel cords for high tensile stress resistance.

Type	Type of belt	Belt width [mm]	Weight kg/m
ROBOT 160 SP	70 AT 10	70	0.41

Tab. 70

Belt length (mm) = 2 x L - 130

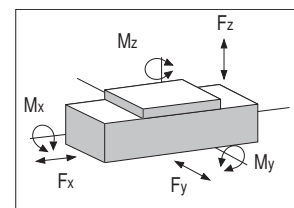

> ROBOT 160 SP-2C DOUBLE INDEPENDENT CARRIAGES

ROBOT 160 SP-2C dimensions

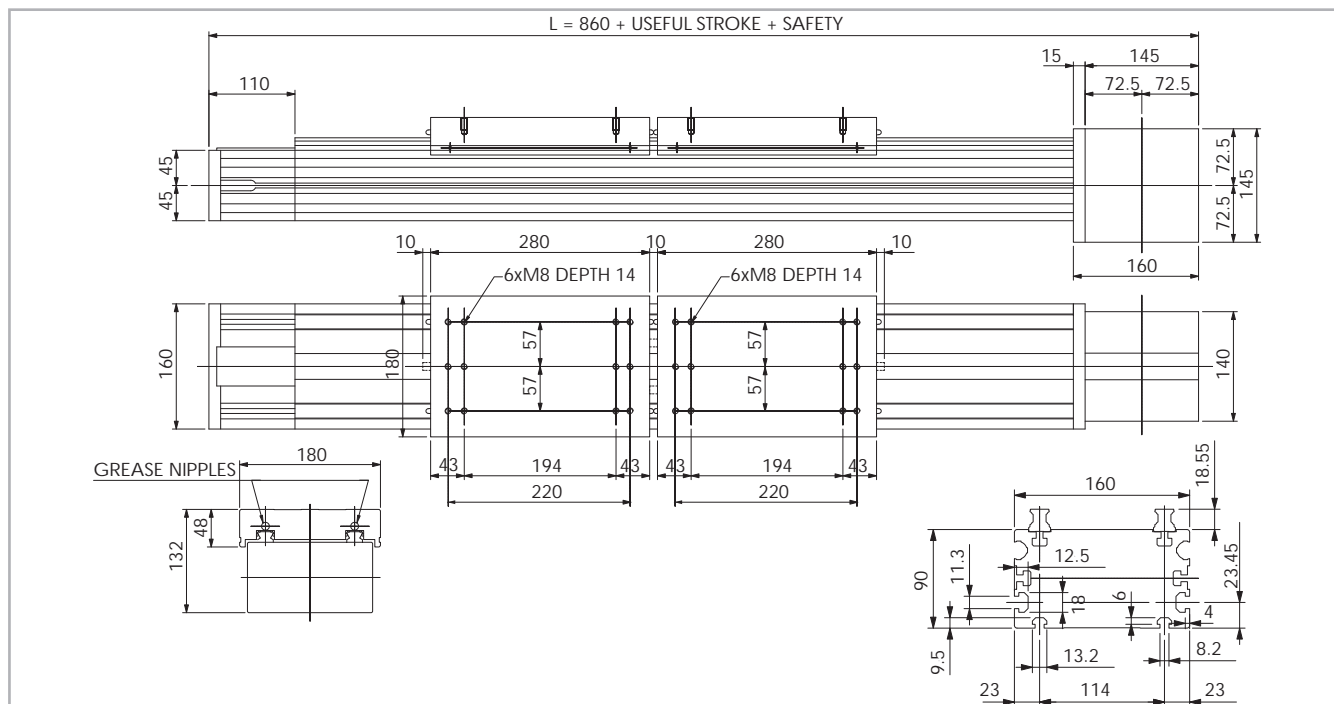

* The length of the safety stroke is provided on request according to the customer's specific requirements.

Fig. 33

Technical data

	Type
	ROBOT 160 SP-2C
Max. useful stroke length [mm]*1	6000
Max. positioning repeatability [mm]*2	± 0.05
Max. speed [m/s]	5.0
Max. acceleration [m/s ²]	50
Type of belt	32 AT 10
Type of pulley	Z 19
Pulley pitch diameter [mm]	60.48
Carriage displacement per pulley turn [mm]	190
Carriage weight [kg]	5.3
Zero travel weight [kg]	21
Weight for 100 mm useful stroke [kg]	1.9
Starting torque [Nm]	4.5
Moment of inertia of pulleys [g mm ²]	210300

*1) It is possible to obtain strokes up to 11000 mm by means of special Rollon joints

*2) Positioning repeatability is dependent on the type of transmission used

Tab. 72

ROBOT 160 SP - Load capacity

Type	F_x [N]		F_y [N]		F_z [N]		M_x [Nm]		M_y [Nm]		M_z [Nm]	
	Stat.	Dyn.	Stat.	Dyn.	Stat.	Dyn.	Stat.	Dyn.	Stat.	Dyn.	Stat.	Dyn.
ROBOT 160 SP-2C	2013	1170	86800	69600	86800	69600	4935	3957	6901	5533	6901	5533

See verification under static load and lifetime on page SL-2 and SL-3

Tab. 75

Moments of inertia of the aluminum body

Type	I_x [10 ⁷ mm ⁴]	I_y [10 ⁷ mm ⁴]	I_p [10 ⁷ mm ⁴]
ROBOT 160	0.37	1.51	1.88

Tab. 73

Driving belt

The driving belt is manufactured from a friction resistant polyurethane and with steel cords for high tensile stress resistance.

Type	Type of belt	Belt width [mm]	Weight kg/m
ROBOT 160 SP-2C	32 AT 10	32	0.185

Tab. 74

Belt length (mm) = 2 x L - 130

Two belts for each actuator.

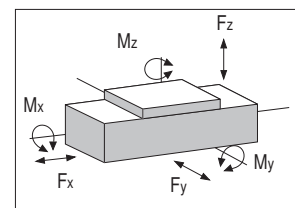

> ROBOT 160 CE

ROBOT 160 CE dimensions

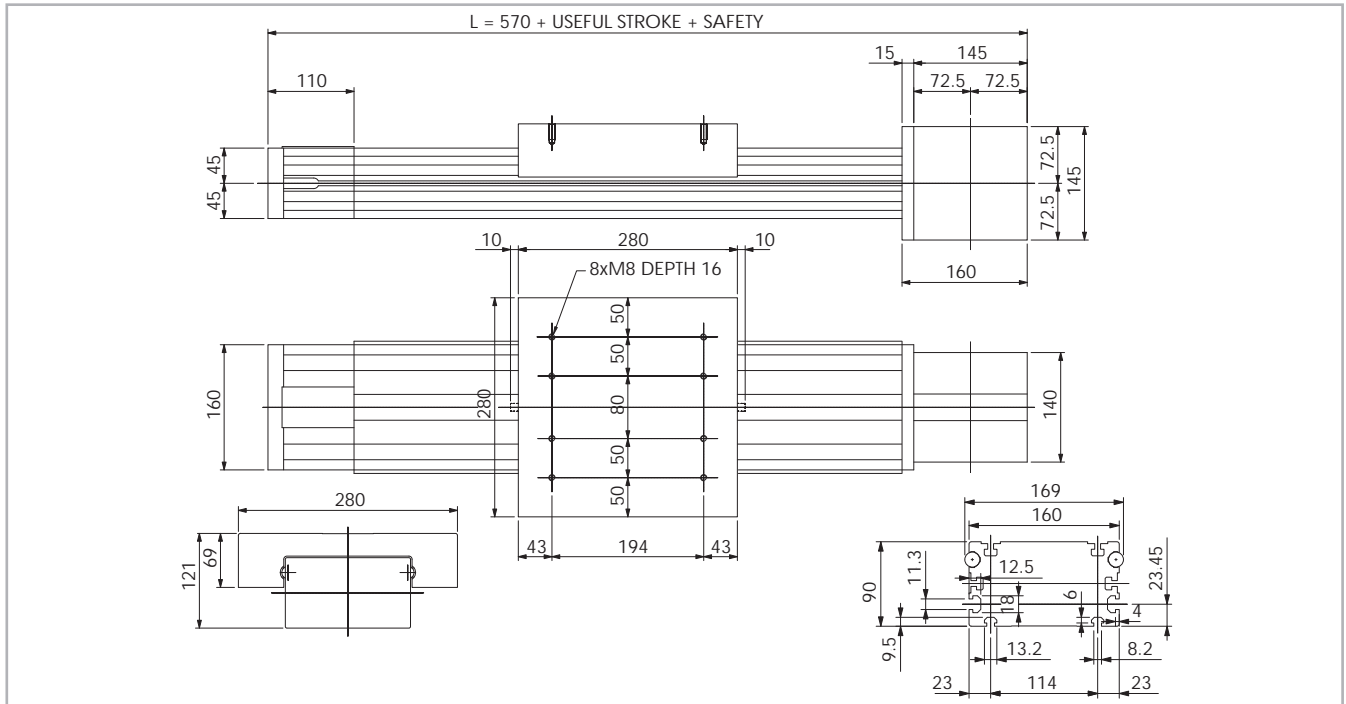

* The length of the safety stroke is provided on request according to the customer's specific requirements.

Fig. 34

Technical data

	Type
	ROBOT 160 CE
Max. useful stroke length [mm]*1	6000
Max. positioning repeatability [mm]*2	± 0.05
Max. speed [m/s]	1.5
Max. acceleration [m/s ²]	1.5
Type of belt	70 AT 10
Type of pulley	Z 20
Pulley pitch diameter [mm]	63.66
Carriage displacement per pulley turn [mm]	200
Carriage weight [kg]	8.6
Zero travel weight [kg]	23
Weight for 100 mm useful stroke [kg]	2.2
Starting torque [Nm]	4.5
Moment of inertia of pulleys [g mm ²]	1.202 · 10 ⁶

Tab. 76

*1) It is possible to obtain strokes up to 11000 mm by means of special Rollon joints

*2) Positioning repeatability is dependent on the type of transmission used

ROBOT 160 CE - Load capacity

Type	F _x [N]		F _y [N]		F _z [N]		M _x [Nm]		M _y [Nm]		M _z [Nm]	
	Stat.	Dyn.	Stat.	Dyn.	Stat.	Dyn.	Stat.	Dyn.	Stat.	Dyn.	Stat.	Dyn.
ROBOT 160 CE	4662	3717	15800	33600	7600	15300	580	1170	820	1650	1710	3630

See verification under static load and lifetime on page SL-2 and SL-3

Tab. 79

Moments of inertia of the aluminum body

Type	I _x [10 ⁷ mm ⁴]	I _y [10 ⁷ mm ⁴]	I _p [10 ⁷ mm ⁴]
ROBOT 160	0.37	1.51	1.88

Tab. 77

Driving belt

The driving belt is manufactured from a friction resistant polyurethane and with steel cords for high tensile stress resistance.

Type	Type of belt	Belt width [mm]	Weight kg/m
ROBOT 160 CE	70 AT 10	70	0.41

Tab. 78

Belt length (mm) = 2 x L - 130

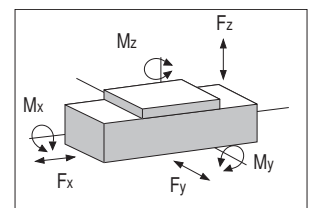

> ROBOT 160 CE-2C DOUBLE INDEPENDENT CARRIAGES

ROBOT 160 CE-2C dimensions

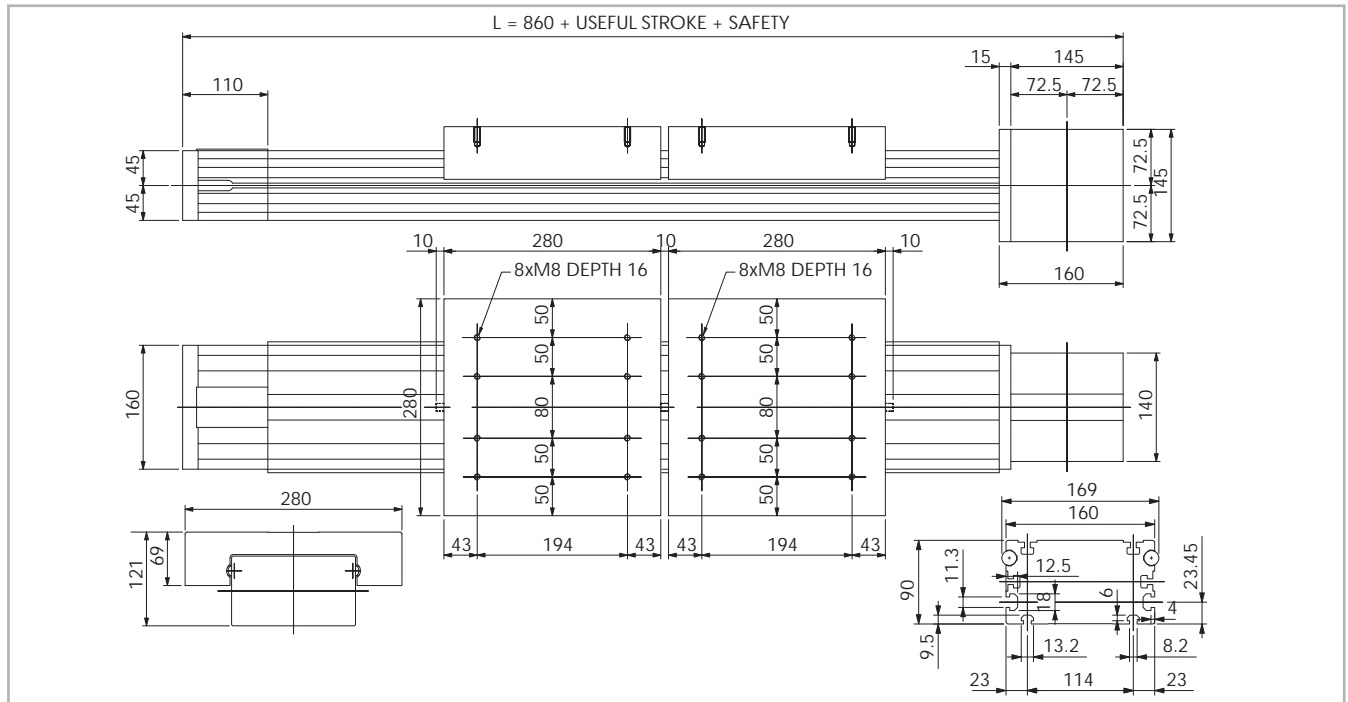

* The length of the safety stroke is provided on request according to the customer's specific requirements.

Fig. 35

Technical data

	Type
	ROBOT 160 CE-2C
Max. useful stroke length [mm]*1	6000
Max. positioning repeatability [mm]*2	± 0.05
Max. speed [m/s]	1.5
Max. acceleration [m/s ²]	1.5
Type of belt	32 AT 10
Type of pulley	Z 19
Pulley pitch diameter [mm]	60.48
Carriage displacement per pulley turn [mm]	190
Carriage weight [kg]	8.6
Zero travel weight [kg]	32
Weight for 100 mm useful stroke [kg]	2.2
Starting torque [Nm]	4.5
Moment of inertia of pulleys [g mm ²]	210300

Tab. 80

*1) It is possible to obtain strokes up to 11000 mm by means of special Rollon joints

*2) Positioning repeatability is dependent on the type of transmission used

ROBOT 160 CE-2C - Load capacity

Type	F _x [N]		F _y [N]		F _z [N]		M _x [Nm]		M _y [Nm]		M _z [Nm]	
	Stat.	Dyn.	Stat.	Dyn.	Stat.	Dyn.	Stat.	Dyn.	Stat.	Dyn.	Stat.	Dyn.
ROBOT 160 CE-2C	2013	1605	15800	33600	7600	15300	580	1170	820	1650	1710	3630

See verification under static load and lifetime on page SL-2 and SL-3

Tab. 83

Moments of inertia of the aluminum body

Type	I _x [10 ⁷ mm ⁴]	I _y [10 ⁷ mm ⁴]	I _p [10 ⁷ mm ⁴]
ROBOT 160	0.37	1.51	1.88

Tab. 81

Driving belt

The driving belt is manufactured from a friction resistant polyurethane and with steel cords for high tensile stress resistance.

Type	Type of belt	Belt width [mm]	Weight kg/m
ROBOT 160 CE-2C	32 AT 10	32	0.185

Tab. 82

$$\text{Belt length (mm)} = 2 \times L - 130$$

Two belts for each actuator.

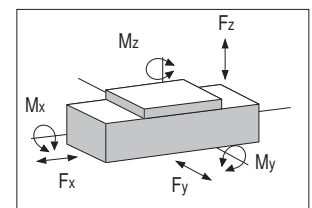

ROBOT 220 SP

ROBOT 220 SP dimensions

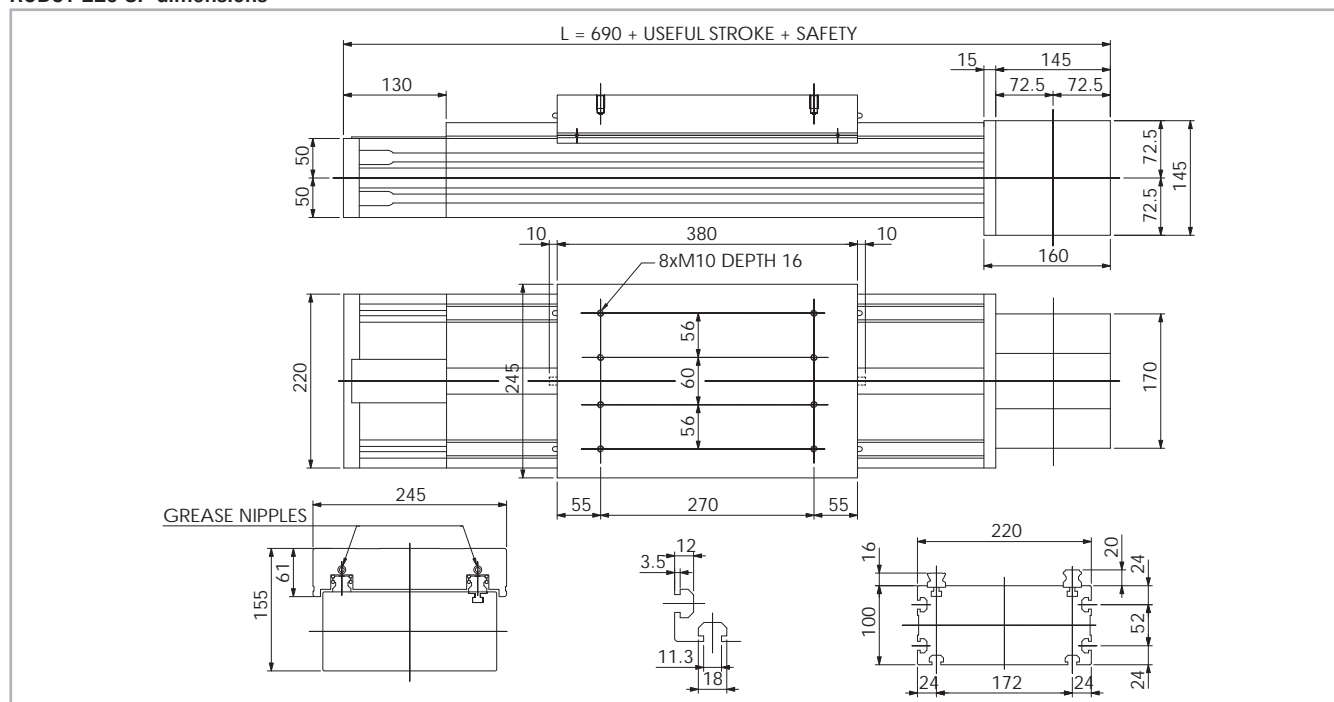

* The length of the safety stroke is provided on request according to the customer's specific requirements.

Fig. 36

Technical data

	Type
	ROBOT 220 SP
Max. useful stroke length [mm]*1	6000
Max. positioning repeatability [mm]*2	± 0.05
Max. speed [m/s]	5.0
Max. acceleration [m/s ²]	50
Type of belt	100 AT 10
Type of pulley	Z 25
Pulley pitch diameter [mm]	79.58
Carriage displacement per pulley turn [mm]	250
Carriage weight [kg]	14.4
Zero travel weight [kg]	41
Weight for 100 mm useful stroke [kg]	2.5
Starting torque [Nm]	6.4
Moment of inertia of each pulley [g mm ²]	4.114 · 10 ⁶

*1) It is possible to obtain strokes up to 11000 mm by means of special Rollon joints

*2) Positioning repeatability is dependent on the type of transmission used

Tab. 84

ROBOT 220 SP - Load capacity

Type	F _x [N]		F _y [N]		F _z [N]		M _x [Nm]		M _y [Nm]		M _z [Nm]	
	Stat.	Dyn.	Stat.	Dyn.	Stat.	Dyn.	Stat.	Dyn.	Stat.	Dyn.	Stat.	Dyn.
ROBOT 220 SP	8510	5520	158000	110000	158000	110000	13588	9460	17696	12320	17696	12320

See verification under static load and lifetime on page SL-2 and SL-3

Tab. 87

Moments of inertia of the aluminum body

Type	I _x [10 ⁷ mm ⁴]	I _y [10 ⁷ mm ⁴]	I _p [10 ⁷ mm ⁴]
ROBOT 220	0.65	3.26	3.92

Tab. 85

Driving belt

The driving belt is manufactured from a friction resistant polyurethane and with steel cords for high tensile stress resistance.

Type	Type of belt	Belt width [mm]	Weight kg/m
ROBOT 220 SP	100 AT 10	100	0.58

Tab. 86

Belt length (mm) = 2 x L - 120

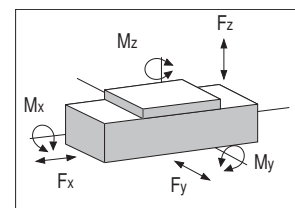

> ROBOT 220 SP-2C DOUBLE INDEPENDENT CARRIAGES

ROBOT 220 SP-2C dimensions

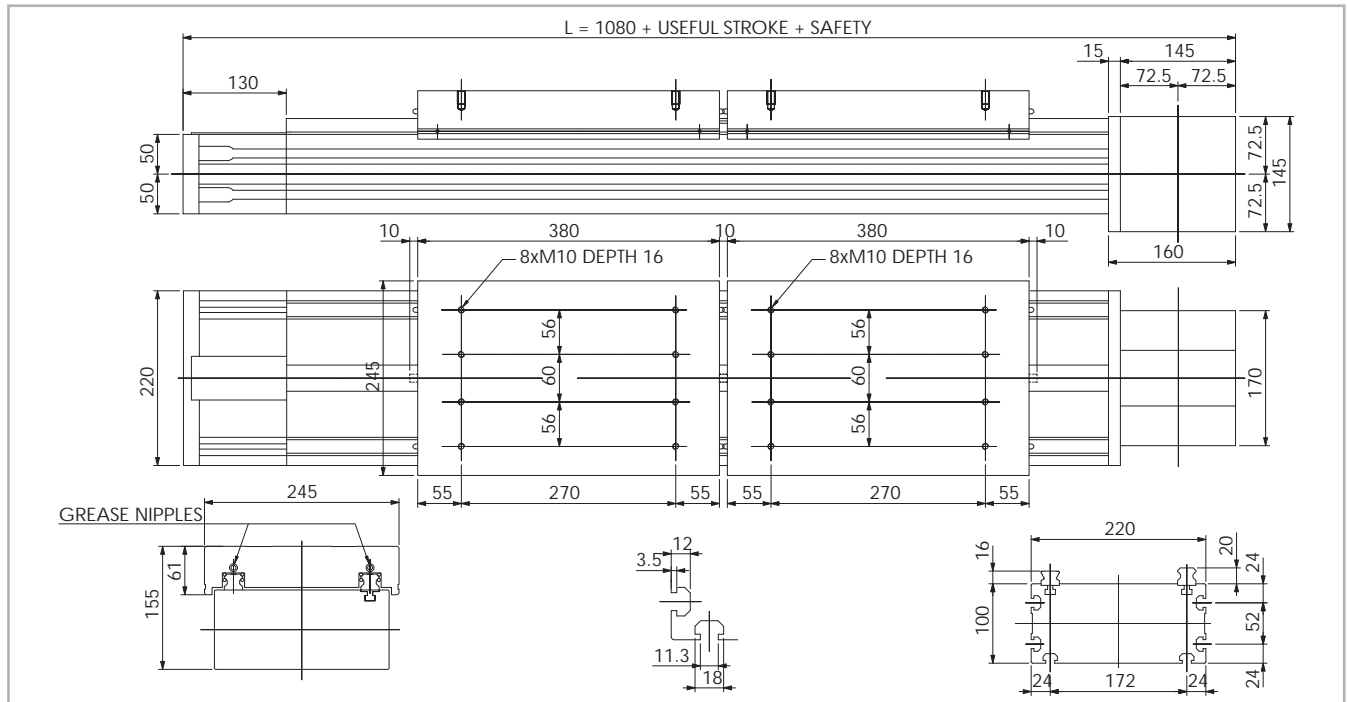

* The length of the safety stroke is provided on request according to the customer's specific requirements.

Fig. 37

Technical data

	Type
	ROBOT 220 SP-2C
Max. useful stroke length [mm]*1	6000
Max. positioning repeatability [mm]*2	± 0.05
Max. speed [m/s]	5.0
Max. acceleration [m/s ²]	50
Type of belt	40 AT 10
Type of pulley	Z 25
Pulley pitch diameter [mm]	79.58
Carriage displacement per pulley turn [mm]	250
Carriage weight [kg]	13.3
Zero travel weight [kg]	46
Weight for 100 mm useful stroke [kg]	2.5
Starting torque [Nm]	6.4
Moment of inertia of pulleys [g mm ²]	2.026 · 10 ⁶

*1) It is possible to obtain strokes up to 11000 mm by means of special Rollon joints

*2) Positioning repeatability is dependent on the type of transmission used

Tab. 88

ROBOT 220 SP-2C - Load capacity

Type	F _x [N]		F _y [N]		F _z [N]		M _x [Nm]		M _y [Nm]		M _z [Nm]	
	Stat.	Dyn.	Stat.	Dyn.	Stat.	Dyn.	Stat.	Dyn.	Stat.	Dyn.	Stat.	Dyn.
ROBOT 220 SP-2C	3404	2208	158000	110000	158000	110000	13588	9460	17696	12320	17696	12320

See verification under static load and lifetime on page SL-2 and SL-3

Tab. 91

Moments of inertia of the aluminum body

Type	I _x [10 ⁷ mm ⁴]	I _y [10 ⁷ mm ⁴]	I _p [10 ⁷ mm ⁴]
ROBOT 220	0.65	3.26	3.92

Tab. 89

Driving belt

The driving belt is manufactured from a friction resistant polyurethane and with steel cords for high tensile stress resistance.

Type	Type of belt	Belt width [mm]	Weight kg/m
ROBOT 220 SP-2C	40 AT 10	40	0.23

Tab. 90

Belt length (mm) = 2 x L - 120

Two belts for each actuator.

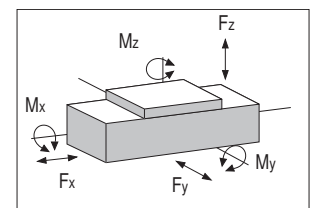

> Lubrication

SP linear units with ball bearing guides

SP Linear units are equipped with self lubricating linear ball guides.

The ball bearing carriages of the SP versions are also fitted with a retention cage that eliminates "steel-steel" contact between adjacent revolving parts and prevents misalignment of these in the circuits.

Special lubrication reservoirs are mounted on the front plates of the linear blocks which continuously provide the necessary amount of grease to the ball raceways under load. These lubrication reservoirs also considerably reduce the frequency of lubrication of the module. This system guarantees

a long interval between maintenances: SP version: every 5000 km or 1 year of use, based on the value reached first. If a longer service life is required or in case of high dynamic or high loaded applications please contact our offices for further verification.

Linear units type CE with gothic arch bearing guides

Linear units with gothic arch bearing guides are equipped with along period lubrication system. Four grease impregnated felt scrapers, complete with grease reservoirs, guarantee a service life of ca. 6000 km without relubrication. If relubrication is required to obtain a higher service life please contact our offices.

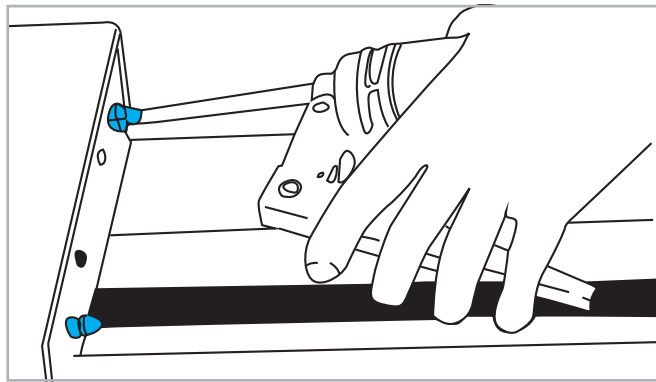

Fig. 38

- Insert grease gun in the specific grease nipples.
- Type of lubricant: Lithium soap grease of class NLGI 2.
- For specially stressed applications or difficult environmental condi-

Quantity of lubricant necessary for re-lubrication for each block:

Type	Unit: [g]
ROBOT 100 SP	1
ROBOT 130 SP	0.8
ROBOT 160 SP	1.4
ROBOT 220 SP	2.8

Tab. 92

tions, lubrication should be carried out more frequently. Apply to Rollon for further advice.

> Planetary gears

Assembly to the right or to the left of the driving head

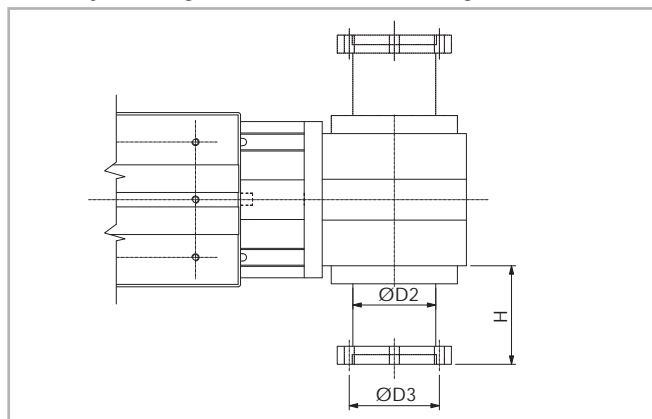
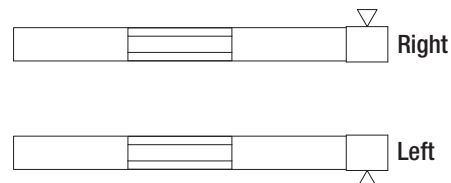

Fig. 39

The series Robot linear units can be fitted with several different drive systems. In each case, the driving pulley is attached to the reduction gear-shaft by means of a tapered coupling to ensure high accuracy over a long period of time.

Versions with planetary gears

Planetary gears are used for highly dynamic robot, automation and handling applications involving stressing cycles and with high level precision requirements. Standard models are available with clearance from 3' to 15' and with a reduction ratio from 1:3 to 1:1000. For assembly of non-standard planetary gear, contact our offices.



> Simple shaft version

Simple shaft type AS

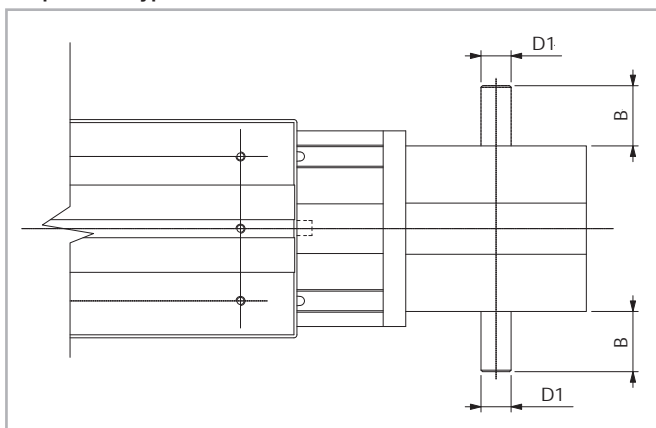

Fig. 40

Unit	Shaft type	B	D1
ROBOT 100	AS 15	35	15h7
ROBOT 130	AS 20	40	20h7
ROBOT 160	AS 25	50	25h7
ROBOT 220	AS 25	50	25h7

Tab. 93

Position of the simple shaft can be to the right, left, or both sides of the drive head.

Unit	Shaft type	Head code AS left	Head code AS right	Head code double AS
ROBOT 100	AS 15	1E	1C	1A
ROBOT 130	AS 20	1E	1C	1A
ROBOT 160	AS 25	1E	1C	1A
ROBOT 220	AS 25	1E	1C	1A

Tab. 94

Simple shaft type AE 10 for encoder assembly + AS

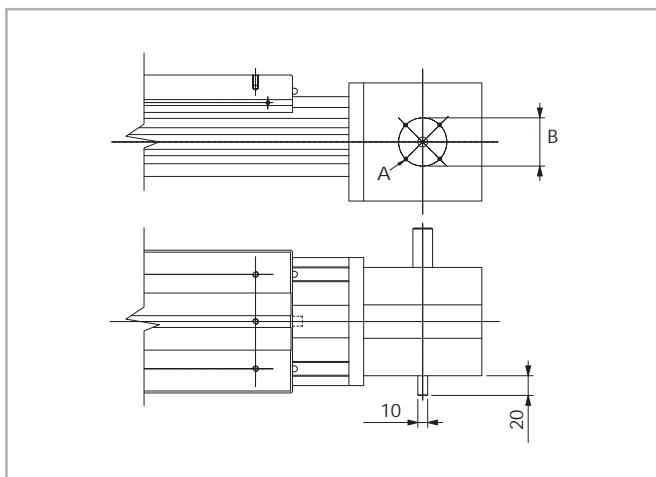

Fig. 41

Unit	A	B	Head code AS right + AE	Head code AS left + AE
ROBOT 100	4xM4	Ø49	1G	1I
ROBOT 130	4xM4	Ø79	1G	1I
ROBOT 160	4xM4	Ø76	1G	1I
ROBOT 220	4xM4	Ø76	1G	1I

Tab. 95

Position of the simple shafts for encoder assembly to the right or to the left on the driving head.

> Hollow shafts

AC hollow shaft type

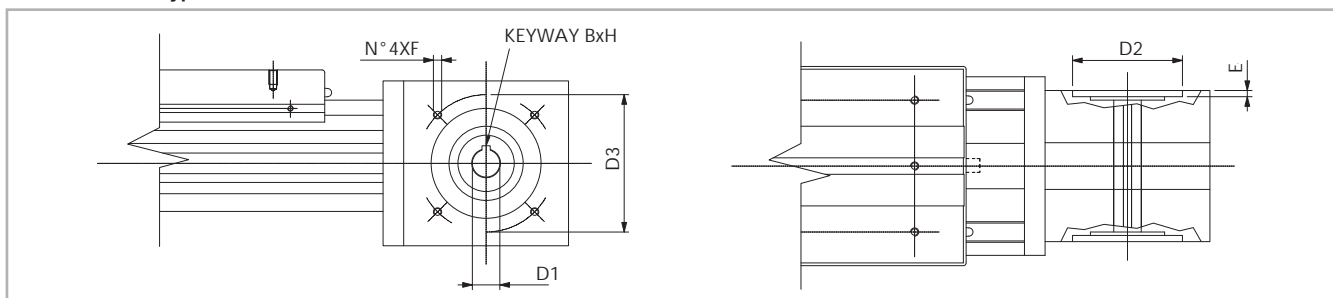

Fig. 42

Unit mm

Applicable to unit	Shaft type	D1	D2	D3	E	F	Keyway B x H	Head code
ROBOT 100	AC19	19H7	80	100	3	M6	6 x 6	2A
ROBOT 130	AC19	19H7	80	100	4.5	M6	6 x 6	2A
ROBOT 130	AC20	20H7	80	100	4.5	M6	6 x 6	2C
ROBOT 130	AC25	25H7	110	130	4.5	M8	8 x 7	2E
ROBOT 160	AC25	25H7	110	130	4.5	M8	8 x 7	2A
ROBOT 160	AC32	32H7	130	165	4.5	M10	10 x 8	2C
ROBOT 220	AC25	25H7	110	130	4.5	M8	8 x 7	2A
ROBOT 220	AC32	32H7	130	165	4.5	M10	10 x 8	2C

Tab. 96

An (optional) connection flange is required to fit the standard reduction units selected by Rollon.

For further informations contact our offices

> Accessories

Fixing by brackets

The linear motion systems used for the Rollon series ROBOT linear units enable support of loads in any direction. They can therefore be installed in any position.

To install the units, we recommend the use of the dedicated T-slots in the extruded bodies as shown below.

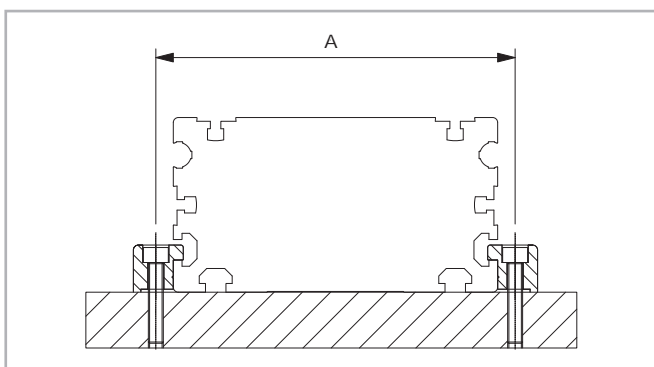

Fig. 43

Unit	A (mm)
ROBOT 100	112
ROBOT 130	144
ROBOT 160	180
ROBOT 220	240

Tab. 97

Fixing brackets

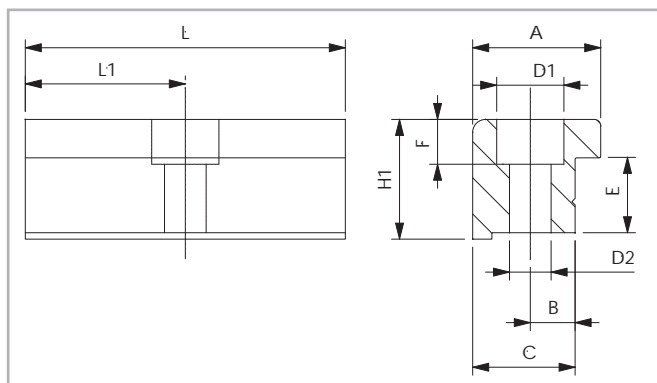

Fig. 44

Anodised aluminum block for fixing the linear units through the side T-slots of the body.

Fixing by T-nuts

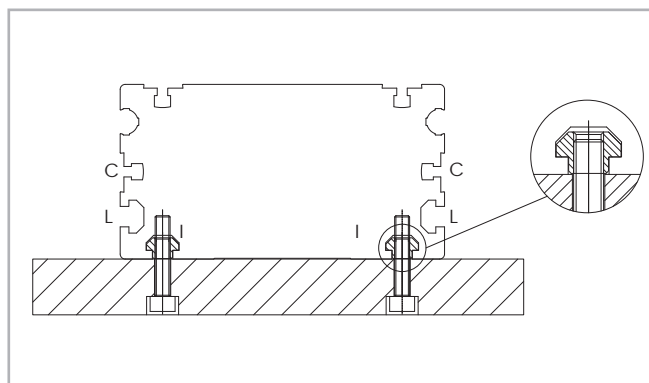

Fig. 45

Warning:
Do not fix the linear units through the drive ends.

Dimensions (mm)

Unit	A	B	C	E	F	D1	D2	H1	L	L1	Code
ROBOT 100	20	6	16	10	5.5	9.5	5.3	14	35	17.5	1000958
ROBOT 130	20	7	16	12.7	7	10.5	6.5	18.7	50	25	1001061
ROBOT 160	36.5	10	31	18.5	10.5	16.5	10.5	28.5	100	50	1001233
ROBOT 220	36.5	10	31	18.5	10.5	16.5	10.5	28.5	100	50	1001233

Tab. 98

T-nuts

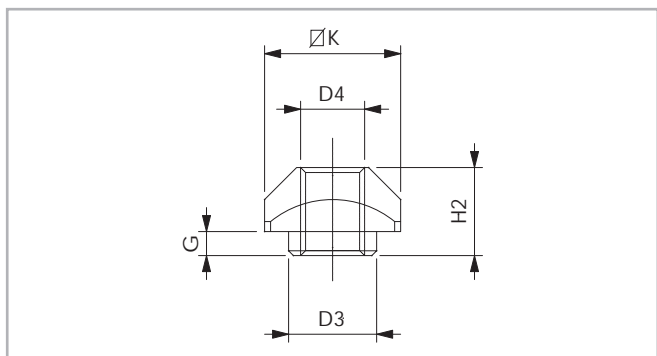

Fig. 46

L=Side / C=Central / I=Lower - see fig. 45

Steel nuts to be used in the slots of the body.

Dimensions (mm)

Unit		D3	D4	G	H2	K	Code
ROBOT 100	L-I	-	M4	-	3.4	8	1001046
ROBOT 130	C	-	M3	-	4	6	1001097
ROBOT 130	L-I	8	M6	3.3	8.3	13	1000043
ROBOT 160	C	-	M6	-	5.8	13	1000910
ROBOT 160	I	8	M6	3.3	8.3	13	1000043
ROBOT 160	L	11	M8	2.8	10.8	17	1000932
ROBOT 220	L-I	11	M8	2.8	10.8	17	1000932

Tab. 99

Proximity ROBOT...SP

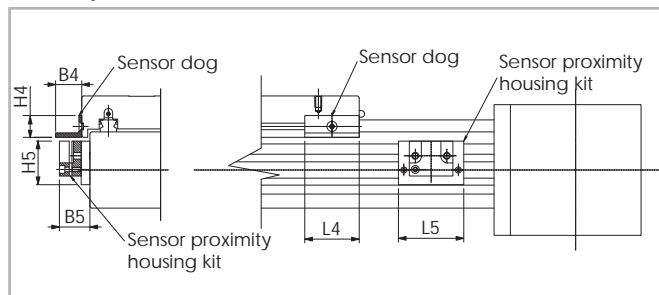

Fig. 47

Sensor proximity housing kit

Red anodized aluminum sensor holder, equipped with T-nuts for fixing into the body slots.

Sensor dog

L-shaped bracket in zinc-plated iron, mounted on the carriage and used for proximity switch operations.

Dimensions (mm)

Unit	B4	B5	L4	L5	H4	H5	For proximity	Sensor dog code	Sensor proximity housing kit code
ROBOT SP 100	9.5	20	25	45	12	25	Ø 8	G000268	G000092
ROBOT SP 130	21	28	50	60	20	40	Ø 12	G000269	G000126
ROBOT SP 160	21	28	50	64	20	40	Ø 12	G000269	G000123
ROBOT SP 220	21	28	50	70	20	40	Ø 12	G000269	G000207

Tab. 100

Warning:

If a bellow is used, it is not possible to assemble the proximity switch holders to the aluminum body.

Proximity ROBOT...CE

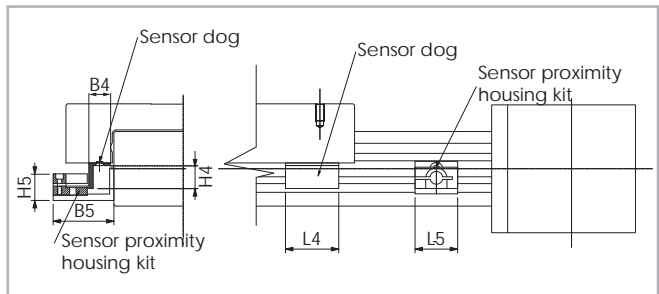

Fig. 48

Sensor proximity housing kit

Red anodized aluminum sensor holder, equipped with T-nuts for fixing into the body slots.

Sensor dog

L-shaped bracket in zinc-plated iron, mounted on the carriage and used for proximity switch operations.

Dimensions (mm)

Unit	B4	B5	L4	L5	H4	H5	For proximity	Sensor dog code	Sensor proximity housing kit code
ROBOT CE 100	9.5	47	25	29	12	20	Ø 8	G000268	G000756
ROBOT CE 130	21	57	50	40	20	25	Ø 12	G000269	G000125
ROBOT CE 160	21	57	50	40	20	28.5	Ø 12	G000269	G000124

Tab. 101

Warning:

If a bellow is used, it is not possible to assemble the proximity switch holders to the aluminum body.

Protections

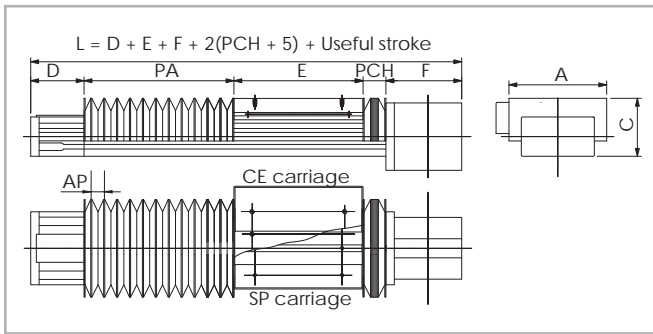

Fig. 49

Standard protections

The Rollon series ROBOT linear units are equipped with a polyurethane sealing strip to protect all parts inside the body against dust and foreign matter. The sealing strip runs the length of the body and is kept in position by micro-bearings located within the carriage. This ensures very low frictional resistance as it passes through the carriage.

Dimensions (mm)

Unit	A	C	D	E	F
ROBOT 130	174	103	95	230	135
ROBOT 160	204	131.5	110	280	160
ROBOT 220	275	149.5	130	380	160

Tab. 102

Protection of ball bearing guides

The four ball bearing blocks have seals on both sides and, where necessary, an additional scraper can be fitted for very dusty conditions.

Special protection

To use these linear units in very critical environments, they can be fitted with a bellows system in addition to the standard protection. The bellows is fixed to the carriage and the ends of the body with Velcro tape for easy assembly and disassembly.

The total length (L) of the linear unit will vary:

See Fig. 49.

Standard material: Thermally welded nylon coated with polyurethane

Materials on demand: Nylon coated with PVC, fiberglass, stainless steel

Warning: The use of bellows does not allow the assembly of the proximity switch holders to the aluminum body.

Assembly kits

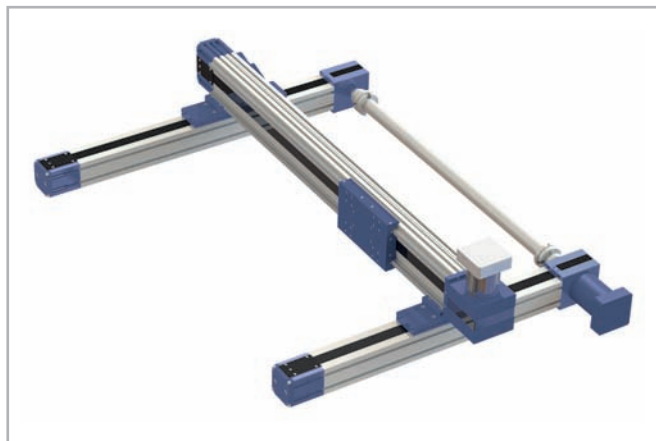

Fig. 50

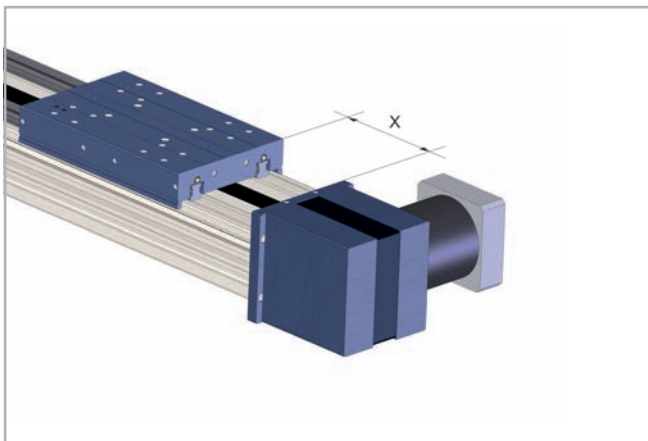

Fig. 51

For the direct assembly of Robot linear units on other types of actuators Rollon offers dedicated assembly kits (brackets) in order to fix those brackets the ends of the actuator must be free of rails. The table below gives the codes of the assembly kit. The allowed combination of assembly as well as the length without rails at each end.

	Kit	Code	X No rail at each end (mm)
	ROBOT 100 - ELM 65	G000205	75
	ROBOT 100 - ROBOT 130	G000201	140
	ROBOT 100 - ECO 80	G000203	90
	ROBOT 100 - E-SMART 50	G000642	60
	ROBOT 130 - ELM 65	G000196	75
	ROBOT 130 - ELM 80	G000195	90
	ROBOT 130 - ROBOT 130	G000197	140
	ROBOT 130 - ROBOT 160	G000198	170
	ROBOT 160 - ELM 80	G000204	90
	ROBOT 160 - ELM 110	G000452	120
	ROBOT 160 - ROBOT 160	G000202	170
	ROBOT 160 - ROBOT 220	G000202	230
	ROBOT 220 - ELM 110	G000199	120

Tab. 103

Ordering key

> Identification codes for the ROBOT linear unit

R	13	1C	2000	1A	-075	D					
	10=100			1A=SP							
	13=130			1E=CE							
	16=160						Multiple carriage				
	22=220						ROBOT	075 ROBOT 130 - ELM 65	090 ROBOT 130 - ELM 80		
							on ELM	075 ROBOT 100 - ELM 65	120 ROBOT 130 - ELM 110		
								120 ROBOT 130 - ELM 110	<i>see pg. PLS-38</i>		
							Linear motion system <i>see pg. PLS-17</i>				
				L = total length of the unit							
				Driving head code <i>see pg. PLS-33 - PLS-34</i>							
		Linear unit size <i>see from pg. PLS-18 to pg. PLS-31</i>									
		Linear unit serie ROBOT <i>see pg. PLS-15</i>									

In order to create identification codes for Actuator Line, you can visit: <http://configureactuator.rollon.com>

SC series



> SC series description



Fig. 52

SC

The SC series linear units are specifically designed for vertical motion in gantry applications, or in applications where the aluminum profile must move while the carriage remains fixed.

Available in three sizes: 65 mm, 130 mm and 160 mm, the SC linear actuator has a self-supporting structure made by a profile (square profile for SC 65) of extruded and anodized aluminum.

The SC is a very stiff vertical system, guaranteed by the use of two parallel linear guides, four "maintenance-free" caged ball bearing blocks and a very wide belt drive.

The SC Series has been designed for heavy loads and high cycle applications. It is specifically designed and configured to be compatible and assembled with the ROBOT Series actuators without the need for adaptor plates.

PLS-40

Corrosion resistant version

All Plus System series of linear actuators are available with stainless steel elements, for applications in harsh environments and/or subject to frequent washes.

The Plus System linear units are constructed using extruded anodized 6060 and 6082 Anti-Corrosive Aluminum, which houses bearings, linear rails, nuts and bolts and components, all of which are made of low carbon SS AISI 303 and 404C steel, to prevent or delay corrosion caused by humidity experienced in the environments where the linear units are used.

Special no-deposit surface treatments are combined with a food grade lubrication system to allow use in highly sensitive applications, such as the food and pharmaceutical industries where product contamination is prohibited.

- Internal stainless steel elements
- Anodized 6060 and 6082 Anti-Corrosive Aluminum Profile
- Very low carbon SS AISI 303 and 404C steel linear rails, nuts and bolts and components
- Lubricated with organic food grade vegetable oils

> The components

Extruded profile

The anodized aluminum extrusions used for the profile of the Rollon SC series linear units were designed and manufactured by industry experts to optimize weight while maintaining mechanical strength. The anodized aluminum alloy 6060 used (see physical-chemical characteristics below) was extruded with dimensional tolerances complying with EN 755-9 standards.

Side slots are provided for fast, trouble-free mounting of accessories (proximity switch runner, etc.). Power cables and/or air hoses (gripper, etc.) can be passed inside the body.

Driving belt

The Rollon SC series linear units use steel reinforced polyurethane drive belts with AT pitch. This belt is ideal due to its high load transmission characteristics, compact size and low noise. Used in conjunction with a

backlash-free pulley, smooth alternating motion can be achieved. Optimization of the maximum belt width/body dimension ratio enables the following performance characteristics to be achieved:

- High speed
- Low noise
- Low wear

Carriage

The carriage is an enveloping structure that houses the entire linear motion system consisting of a drive pulley and two driven pulleys. The external parts are made of anodized aluminum. Dimensions vary according to type. One of the two configurations shown on page PLS-48 can be used for fast, simple assembly of the SC series. The carriage also houses brush seals to remove contaminants from the system.

General data about aluminum used: AL 6060

Chemical composition [%]

Al	Mg	Si	Fe	Mn	Zn	Cu	Impurities
Remainder	0.35-0.60	0.30-0.60	0.30	0.10	0.10	0.10	0.05-0.15

Tab. 104

Physical characteristics

Density	Coeff. of elasticity	Coeff. of thermal expansion (20°-100°C)	Thermal conductivity (20°C)	Specific heat (0°-100°C)	Resistivity	Melting point
$\frac{\text{kg}}{\text{dm}^3}$	$\frac{\text{kN}}{\text{mm}^2}$	$\frac{10^{-6}}{\text{K}}$	$\frac{\text{W}}{\text{m} \cdot \text{K}}$	$\frac{\text{J}}{\text{kg} \cdot \text{K}}$	$\Omega \cdot \text{m} \cdot 10^{-9}$	°C
2.7	69	23	200	880-900	33	600-655

Tab. 105

Mechanical characteristics

Rm	Rp (02)	A	HB
$\frac{\text{N}}{\text{mm}^2}$	$\frac{\text{N}}{\text{mm}^2}$	%	—
205	165	10	60-80

Tab. 106

> The linear motion system

The linear motion system has been designed to meet the load capacity, speed, and maximum acceleration conditions of a wide variety of applications.

SC series with ball bearing guides

- Two ball bearing guides with high load capacity are mounted in two dedicated seats on the outer sides of the aluminum body.
- The carriage of the linear unit is assembled on four pre-loaded ball bearing blocks with plastic retention cages.
- The four ball row configuration enables the carriage to withstand loading in the four main directions.
- The four blocks have seals on both sides and, where necessary, an additional scraper can be fitted for very dusty conditions.
- Lubrication reservoirs (pockets) installed on the front of the ball bearing blocks supply the right amount of grease, thus promoting long maintenance intervals.

The linear motion system described above offers:

- High speed and acceleration
- High load capacity
- High permissible bending moments
- Low friction
- Long life
- Low noise
- Free maintenance (dependent on application)

SC section

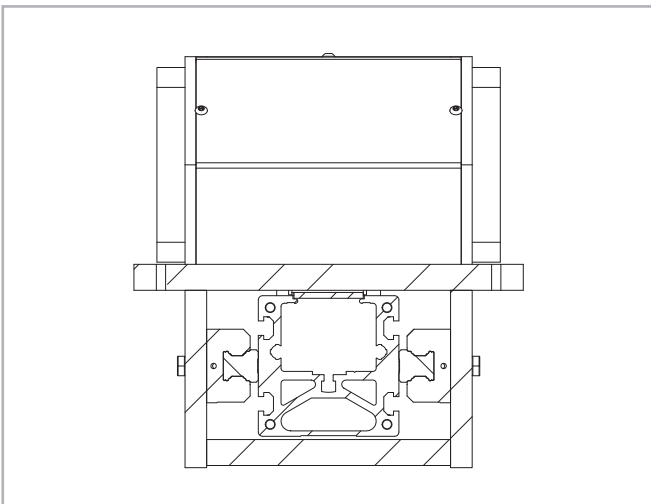
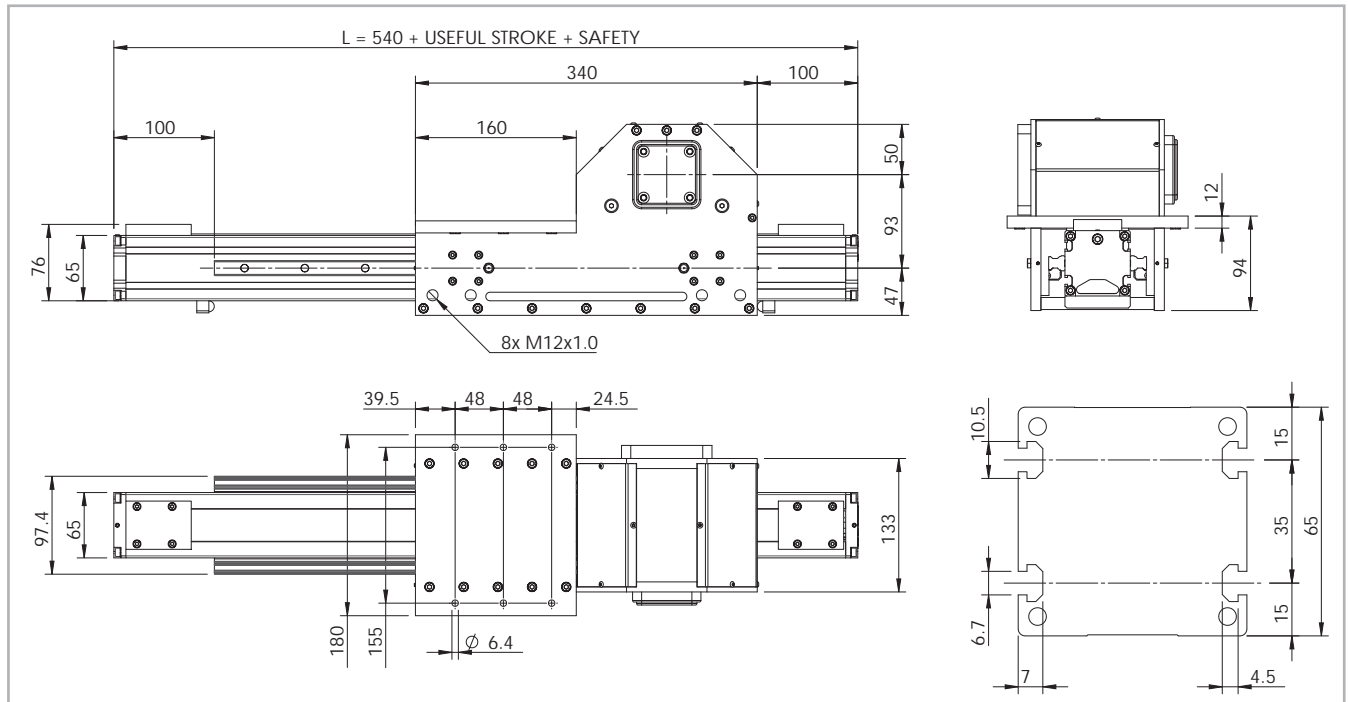

Fig. 53

> SC 65 SP

SC 65 SP Dimensions



* The length of the safety stroke is provided on request according to the customer's specific requirements.

Fig. 54

Technical data

	Type
	SC 65 SP
Max. useful stroke length [mm]	1500
Max. positioning repeatability [mm]*1	± 0.05
Max. speed [m/s]	5.0
Max. acceleration [m/s ²]	50
Type of belt	32 AT 5
Type of pulley	Z 32
Pulley pitch diameter [mm]	50.93
Carriage displacement per pulley turn [mm]	160
Carriage weight [kg]	7.8
Zero travel weight [kg]	11.6
Weight for 100 mm useful stroke [kg]	0.7
Starting torque [Nm]	1.3

*1) Positioning repeatability is dependent on the type of transmission used

Tab. 107

Moments of inertia of the aluminum body

Type	I _x [10 ⁷ mm ⁴]	I _y [10 ⁷ mm ⁴]	I _p [10 ⁷ mm ⁴]
SC 65	0.06	0.09	0.15

Tab. 108

Driving belt

The driving belt is manufactured from a friction resistant polyurethane and with steel cords for high tensile stress resistance.

Type	Type of belt	Belt width [mm]	Weight kg/m
SC 65	32 AT 5	32	0.105

Tab. 109

Belt length (mm) = L + 85

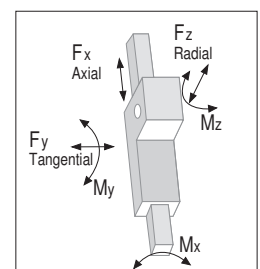

SC 65 SP - Load capacity

Type	F _x [N]		F _y [N]		F _z [N]		M _x [Nm]		M _y [Nm]		M _z [Nm]	
	Stat.	Dyn.	Stat.	Dyn.	Stat.	Dyn.	Stat.	Dyn.	Stat.	Dyn.	Stat.	Dyn.
SC 65 SP	1344	883	48400	29120	48400	29120	1573	946	5808	3494	5808	3494

See verification under static load and lifetime on page SL-2 and SL-3

Tab. 110

> SC 130 SP

SC 130 SP Dimensions

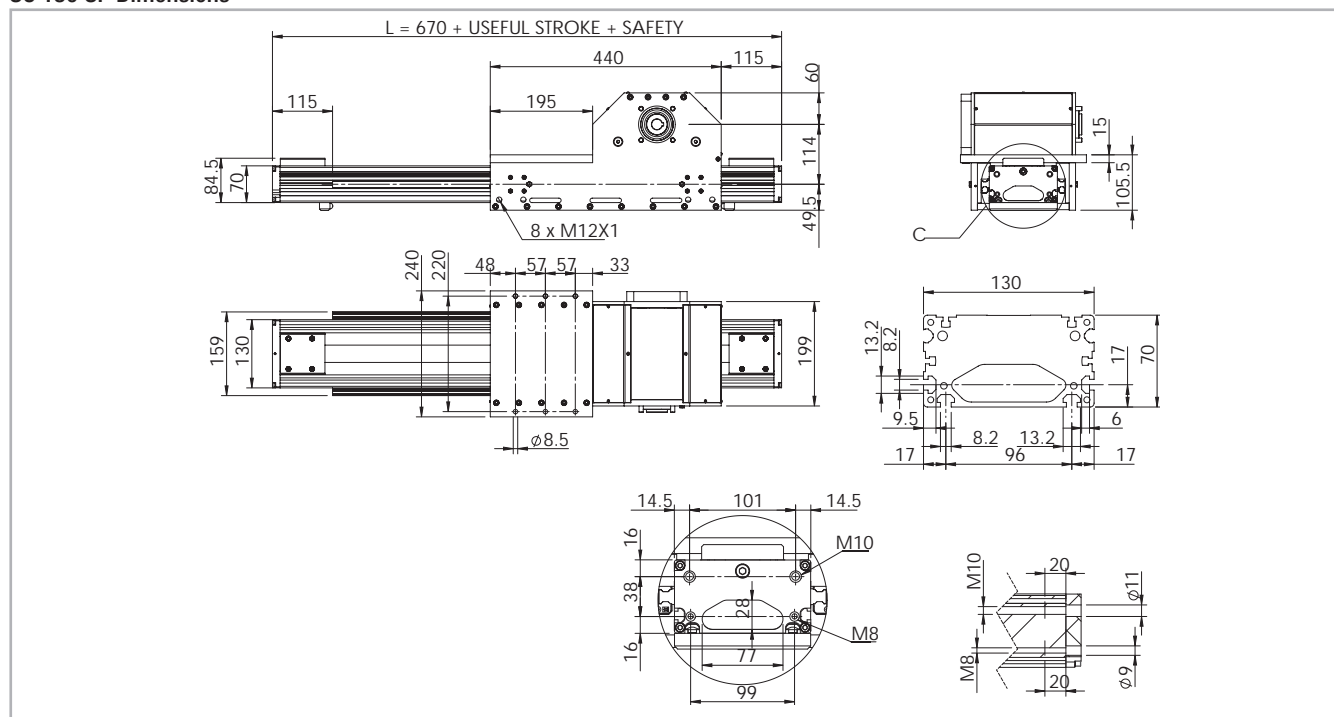

* The length of the safety stroke is provided on request according to the customer's specific requirements.

Fig. 55

Technical data

	Type
	SC 130 SP
Max. useful stroke length [mm]	2000
Max. positioning repeatability [mm]*1	± 0.05
Max. speed [m/s]	5.0
Max. acceleration [m/s ²]	50
Type of belt	50 AT 10
Type of pulley	Z 20
Pulley pitch diameter [mm]	63.66
Carriage displacement per pulley turn [mm]	200
Carriage weight [kg]	13.5
Zero travel weight [kg]	23
Weight for 100 mm useful stroke [kg]	1.4
Starting torque [Nm]	3

*1) Positioning repeatability is dependent on the type of transmission used

Tab. 111

Moments of inertia of the aluminum body

Type	I_x [10 ⁷ mm ⁴]	I_y [10 ⁷ mm ⁴]	I_p [10 ⁷ mm ⁴]
SC 130	0.15	0.65	0.79

Tab. 112

Driving belt

The driving belt is manufactured from a friction resistant polyurethane and with steel cords for high tensile stress resistance.

Type	Type of belt	Belt width [mm]	Weight kg/m
SC 130	50 AT 10	50	0.209

Tab. 113

Belt length (mm) = L + 101

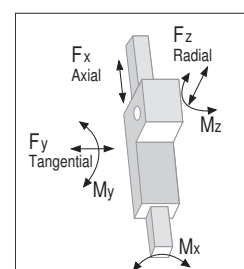

SC 130 SP - Load capacity

Type	F_x [N]		F_y [N]		F_z [N]		M_x [Nm]		M_y [Nm]		M_z [Nm]	
	Stat.	Dyn.	Stat.	Dyn.	Stat.	Dyn.	Stat.	Dyn.	Stat.	Dyn.	Stat.	Dyn.
SC 130 SP	3330	1980	48400	29120	48400	29120	3073	1849	8155	4907	8155	4907

See verification under static load and lifetime on page SL-2 and SL-3

Tab. 114

> SC 160 SP

SC 160 SP Dimensions

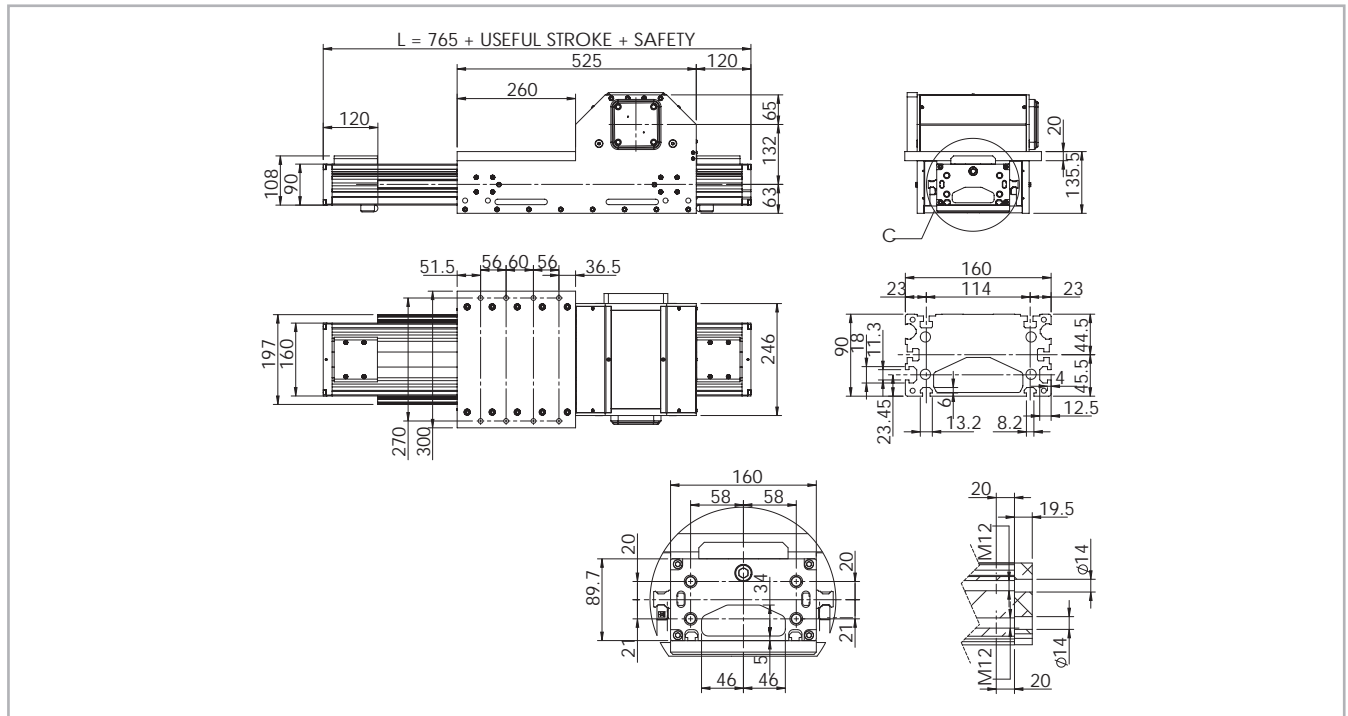

Fig. 56

Technical data

	Type
	SC 160 SP
Max. useful stroke length [mm]	2500
Max. positioning repeatability [mm]*1	± 0.05
Max. speed [m/s]	5.0
Max. acceleration [m/s ²]	50
Type of belt	70 AT 10
Type of pulley	Z 25
Pulley pitch diameter [mm]	79.58
Carriage displacement per pulley turn [mm]	250
Carriage weight [kg]	32
Zero travel weight [kg]	48
Weight for 100 mm useful stroke [kg]	1.9
Starting torque [Nm]	6.1

*1) Positioning repeatability is dependent on the type of transmission used

Tab. 115

Moments of inertia of the aluminum body

Type	I _x [10 ⁷ mm ⁴]	I _y [10 ⁷ mm ⁴]	I _p [10 ⁷ mm ⁴]
SC 160	0.37	1.50	1.88

Tab. 116

Driving belt

The driving belt is manufactured from a friction resistant polyurethane and with steel cords for high tensile stress resistance.

Type	Type of belt	Belt width [mm]	Weight kg/m
SC 160	70 AT 10	70	0.407

Tab. 117

Belt length (mm) = L + 121

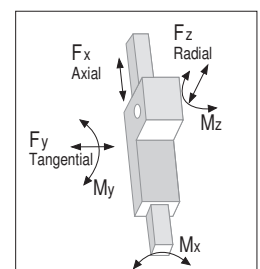

SC 160 SP - Load capacity

Type	F _x [N]		F _y [N]		F _z [N]		M _x [Nm]		M _y [Nm]		M _z [Nm]	
	Stat.	Dyn.	Stat.	Dyn.	Stat.	Dyn.	Stat.	Dyn.	Stat.	Dyn.	Stat.	Dyn.
SC 160 SP	5957	3864	86800	69600	86800	69600	6770	5429	17577	14094	17577	14094

See verification under static load and lifetime on page SL-2 and SL-3

Tab. 118

> Lubrication

SP linear units with ball bearing guides

SP Linear units are equipped with self lubricating linear ball guides. The ball bearing carriages of the SP versions are also fitted with a retention cage that eliminates "steel-steel" contact between adjacent revolving parts and prevents misalignment of these in the circuits. Special lubrication reservoirs are mounted on the front plates of the linear blocks which continuously provide the necessary amount of grease to the

ball raceways under load. These lubrication reservoirs also considerably reduce the frequency of lubrication of the module. This system guarantees a long interval between maintenances: SP version: every 5000 km or 1 year of use, based on the value reached first. If a longer service life is required or in case of high dynamic or high loaded applications please contact our offices for further verification.

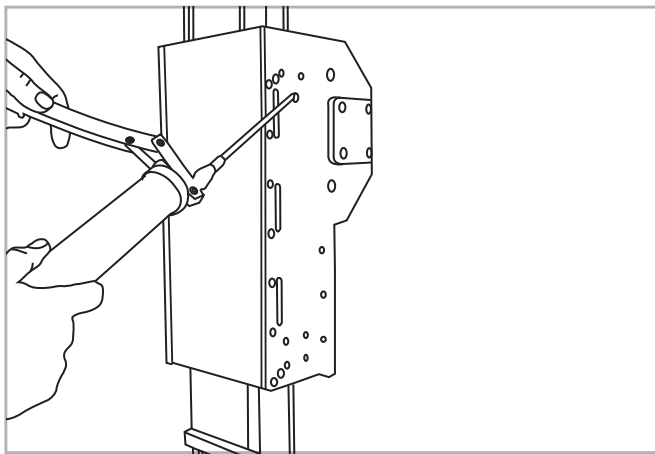

Fig. 57

- Insert the tip of the grease gun in the specific grease blocks.
- For lubrication of linear units use lithium soap grease NLGI 2.
- For specially stressed applications or difficult environmental

Quantity of lubricant necessary for re-lubrication for each block:

Type	Unit: [g]
SC 65	0.8
SC 130	0.8
SC 160	1.4

Tab. 119

conditions, lubrication should be carried out more frequently. Apply to Rollon for further advice.

> Planetary gears

Assembly to the right or to the left of the driving head

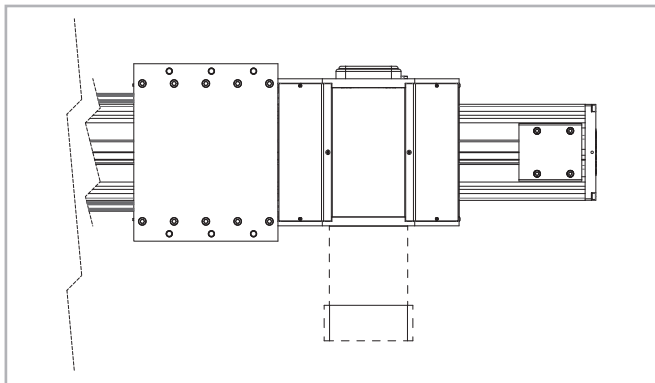

Fig. 58

Motion can be achieved with standard transmission types as follows:

- Planetary gears
- Worm gears
- Versions with simple shaft
- Versions with hollow shaft

Versions with planetary gears

Planetary gears are used for highly dynamic robot, automation and handling applications involving stressing cycles and with high level precision requirements. Standard models are available with a clearance ranging from 3' to 15' and with a reduction ratio from 1:3 to 1:1000. For assembly of non-standard planetary gear, contact our offices.

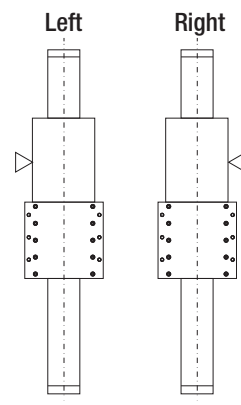

> Simple shaft version

Simple shaft type AS

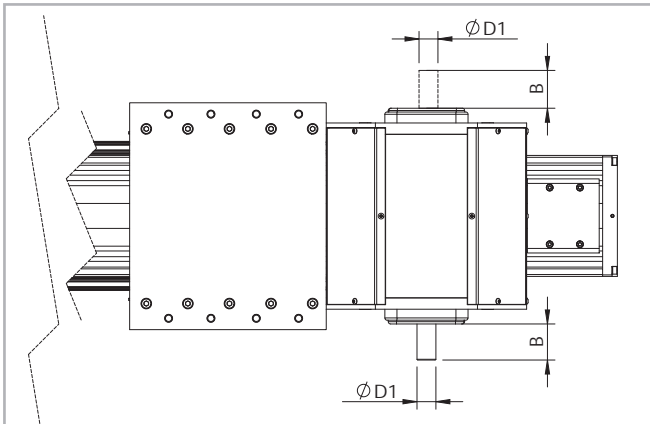

Fig. 59

Unit	Shaft type	B	D1
SC 65	AS 20	40	20h7
SC 130	AS 25	50	25h7
SC 160	AS 25	50	25h7

Tab. 120

Position of the simple shaft can be to the left or right of the drive head.

Unit	Shaft type	Head code AS left	Head code AS right	Head code double AS
SC 65	AS 20	1EA	1CA	1AA
SC 130	AS 25	1EA	1CA	1AA
SC 160	AS 25	1EA	1CA	1AA

Tab. 121

> Hollow shafts

AC hollow shaft type

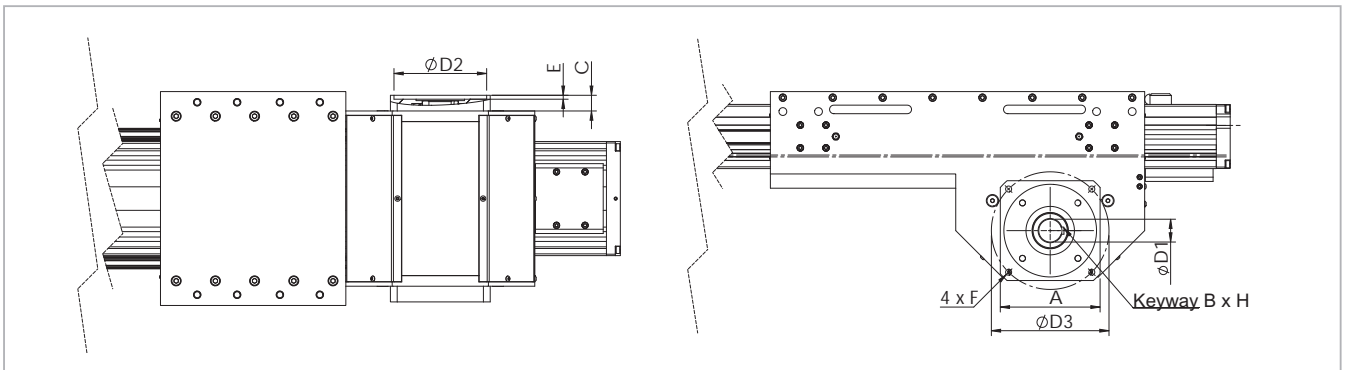

Fig. 60

Unit mm

Applicable to unit	Shaft type	D1	D2	D3	A	B	E	F	Keyway B x H	Head code
SC 65 SP	AC 19	19H7	80	100	90	13	3	M6	6 x 6	2AA
SC 65 SP	AC 20	20H7	80	100	90	13	3	M6	6 x 6	2BA
SC 130 SP	AC 20	20H7	80	100	115	19	4.5	M6	6 x 6	2AA
SC 130 SP	AC 25	25H7	110	130	115	19	4.5	M8	8 x 7	2BA
SC 160 SP	AC 32	32H7	130	165	140	22	5.5	M10	10 x 8	2AA

Tab. 122

An (optional) connection flange is required to fit the standard reduction units selected by Rollon.

For further information contact our offices

> Accessories

Fixing by brackets

The ball bearing guide linear drive systems of Rollon SC series linear units enable support of loads in any direction. They can therefore be installed in any position. To install the SC series units, we recommend use of one of the two systems indicated below:

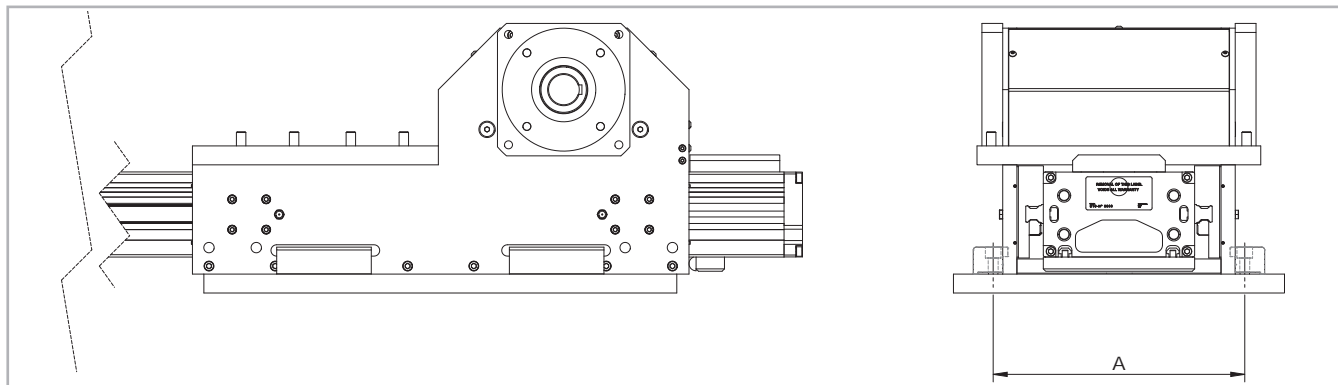

Fig. 61

Fixing brackets

Material: Anodized aluminum

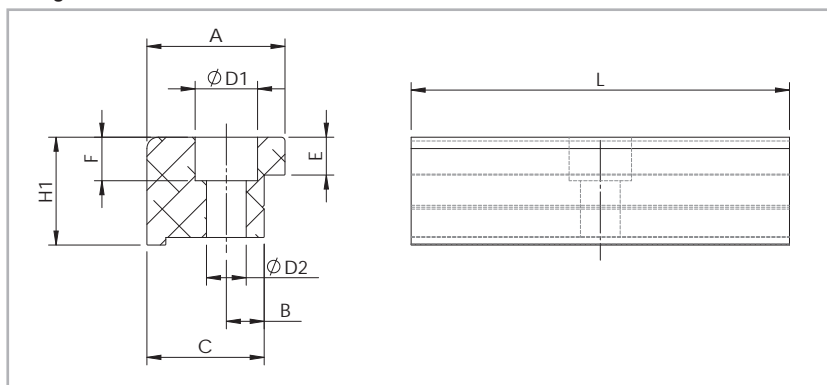

Fig. 62

Unit	A (mm)
SC 65 SP	147
SC 130 SP	213
SC 160 SP	266

Tab. 123

Unit	A	B	C	E	F	D1	D2	H1	L	Code
SC 65 SP	20	6	16	10	5.5	9.5	5.3	14	35	1001491
SC 130 SP	20	7	16	12.7	7	10.5	6.5	18.7	50	1001491
SC 160 SP	36.5	10	31	18.5	10.5	16.5	10.5	28.5	100	1001233

Tab. 124

Direct fixing

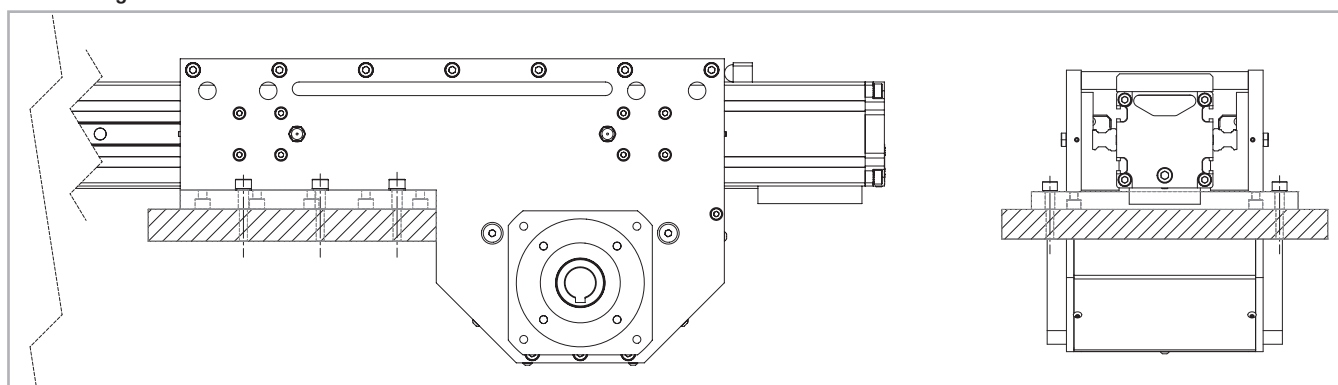

Fig. 63

T-nuts

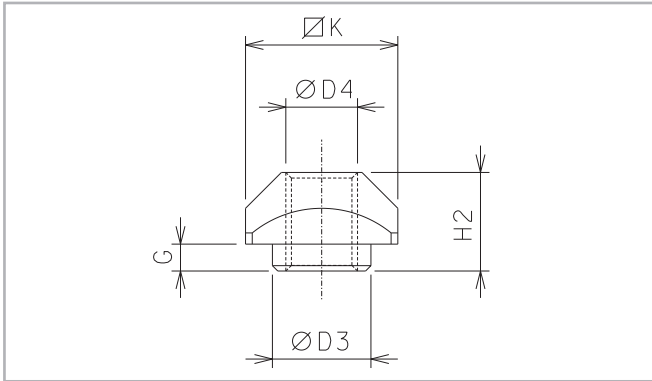

Fig. 64

Steel nuts to be used in the slots of the body

Fixing by T-nuts

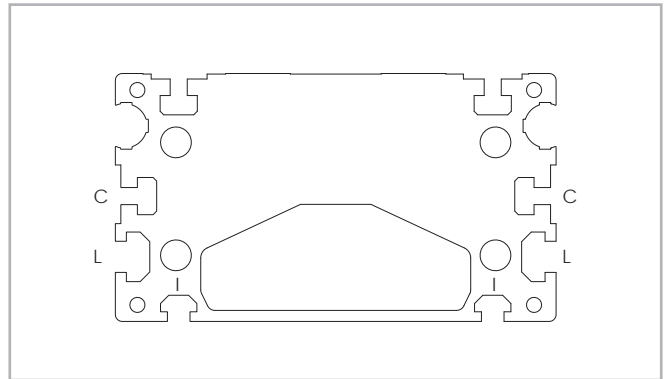

Fig. 65

Warning:

Do not fix the linear units through the drive ends.

Unit	Slot	D3	D4	G	H2	K	Code
SC 65	L	6.7	M5	2.3	6.5	10	1000627
SC 130	L-I	8	M6	3.3	8.3	13	1000043
SC 130	C	-	M3	-	4	6	1001097
SC 160	I	8	M6	3.3	8.3	13	1000043
SC 160	L	11	M8	2.8	10.8	17	1000932
SC 160	C	-	M6	-	5.8	13	1000910

L = Side - I = Lower - C=Central

Tab. 125

Proximity

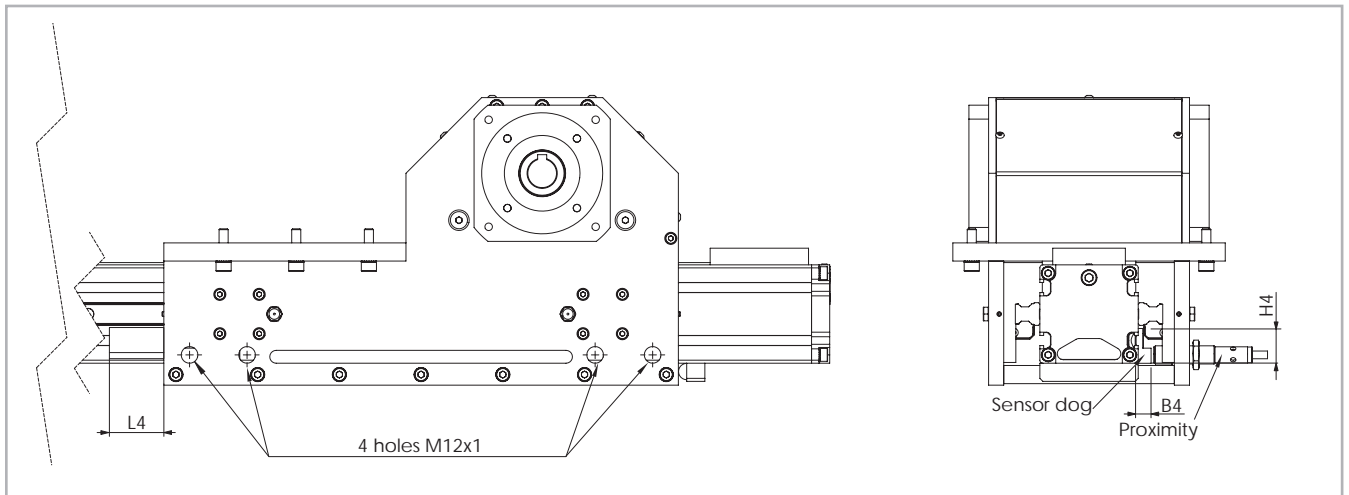

Fig. 66

Fitting of the proximity switch

Proximity switches can be mounted on four threaded mounting holes that are positioned on the sides of the carriage. Do not over-torque the switches during installation as this can cause interference with the proximity switch runner and damage the sensor.

Sensor dog

L-shaped bracket in zinc-plated iron, mounted on the carriage and used for proximity switch operations.

Unit	B4	H4	L4	Sensor dog Code
SC 65	8.5	23	50	G000270
SC 130	8.4	25	50	G000271
SC 160	10	27	50	G000272

Tab. 126

Protections

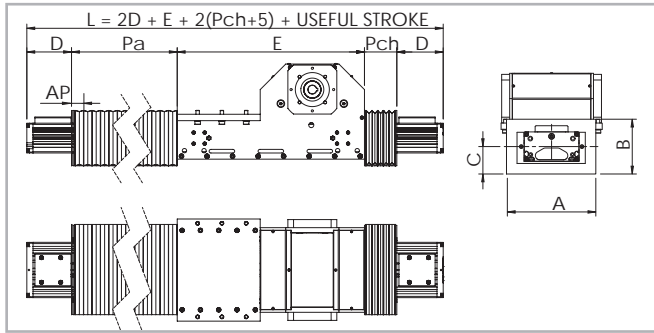

Fig. 67

Protection of ball bearing guides

The four ball bearing blocks have seals on both sides and, where necessary, an additional scraper can be fitted for very dusty conditions.

Special protection

For use in hostile conditions, the SC can be fitted with bellows system in addition to the standard protection. The bellows is fixed to the carriage and drive ends with hook and loop fasteners for ease of assembly and disassembly.

The total length (L) of the linear unit will vary:

See Fig. 67.

Dimensions (mm)

Unit	A	B	C	D	E
SC 65	135	109	54,5	100	340
SC 130	212	130	64	115	440
SC 160	248	150	73	120	525

Tab. 127

Standard material: Thermally welded nylon coated with polyurethane

Materials on demand: Nylon coated with PVC, fiberglass, stainless steel

Warning: The use of bellows does not allow the assembly of the proximity switch holders to the aluminum body.

Ordering key

> Identification codes for the SC linear unit

S	13	1 CA	2000	1A	Linear motion system <i>see pg. PLS-42</i>
	06=65			1A=SP	
	13=130				
	16=160				
			L = total length of the unit		
			Driving head code <i>see pg. PLS-47</i>		
			Linear unit size <i>see from pg. PLS-43 to pg. PLS-45</i>		
			Linear unit series SC <i>see pg. PLS-40</i>		

In order to create identification codes for Actuator Line, you can visit: <http://configureactuator.rollon.com>

Multiaxis systems



Previously, customers wishing to build multiaxis units have had to design, draw and manufacture all the elements necessary to assemble two or more axis. Rollon now offers a set of fittings including brackets and cross plates, to enable multiaxis units to be built. The SC series is also pre-

engineered to facilitate direct connection with the units of the ROBOT series. In addition to standard elements, Rollon also provides plates for special applications.

Application examples:

Two axis - X-Y system

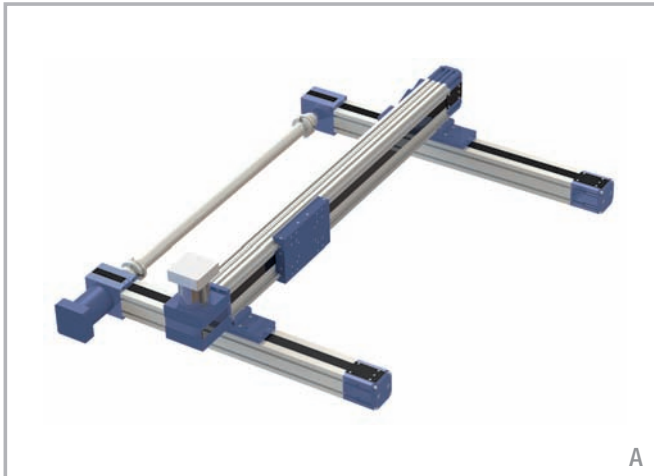

A - Linear units: X axis: 2 ELM 80 SP... Y axis: 1 ROBOT 160 SP...
Connection part: 2 kits of fixing brackets for ROBOT 160 SP... on to the carriages of ELM 80 SP...

Three axis - X-Y-Z system

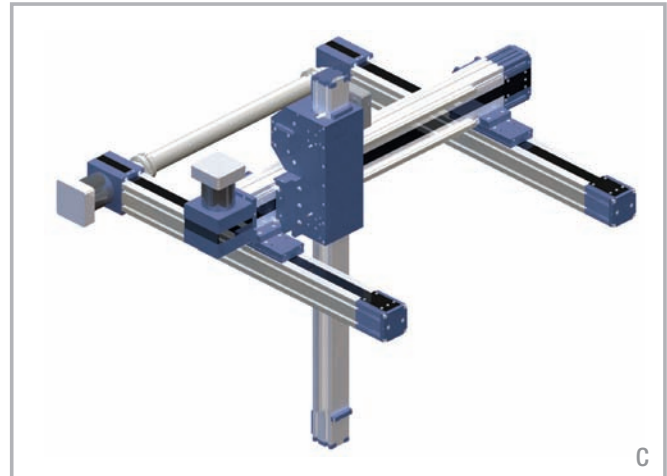

C - Linear units: X axis: 2 ELM 65 SP... Y axis: 1 ROBOT 130 SP...
 Z axis: 1 SC 65
Connection part: 2 kits of fixing brackets for ROBOT 130 SP... on to the carriages of ELM 65 SP... The SC 65 unit is directly assembled on to the ROBOT 130 SP... unit without further elements.

Two axis - Y-Z system



B - Linear units: X axis: 1 ROBOT 220 SP... Z axis: 1 SC 160
Connection part: None
 The SC 160 unit is directly assembled on to the ROBOT 220 SP... unit without further elements

Three axis - X-Y-Z system

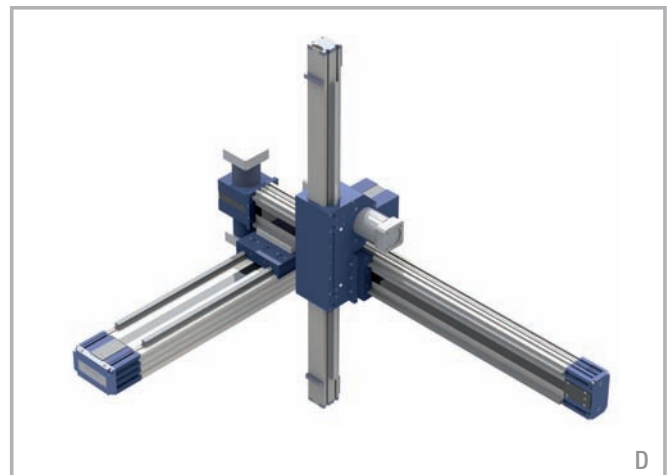

D - Linear units: X axis: 1 ROBOT 220 SP... Y axis: 1 ROBOT 130 SP...
 Z axis: SC 65
Connection part: 1 kit of fixing brackets for ROBOT 130 SP... unit to the carriage of the ROBOT 220 SP... unit. The SC 65 unit is directly assembled on to the ROBOT 130 SP... unit without further elements.

ROLLON[®]
Linear Evolution

Clean Room System



INTL. PATENT PENDING

ONE series**> ONE series description**

Fig. 1

The ONE series actuators are belt driven linear actuators specifically designed for Clean Room applications. The ONE series is certified compliant with ISO CLASS 3 (DIN EN ISO 14644-1) and CLASS 1 US FED STD 209E cleanroom standards by the Fraunhofer Institute IPA in Stuttgart.

The ONE series reduces particle contamination using a specially designed straight seal that isolates the internals of the actuator from the environment. In addition to particle containment, the ONE series can support a vacuum pump (up to 0,8 bar) to remove and transport contaminates from the interior of the actuator to filtration sites. The 2 vacuum ports are located on the drive and idle head.

All internal components of the ONE series actuators are designed to minimize particle release. Component materials are limited to stainless steel. Where stainless steel is not an option, special treatments are used to ensure low particle release.

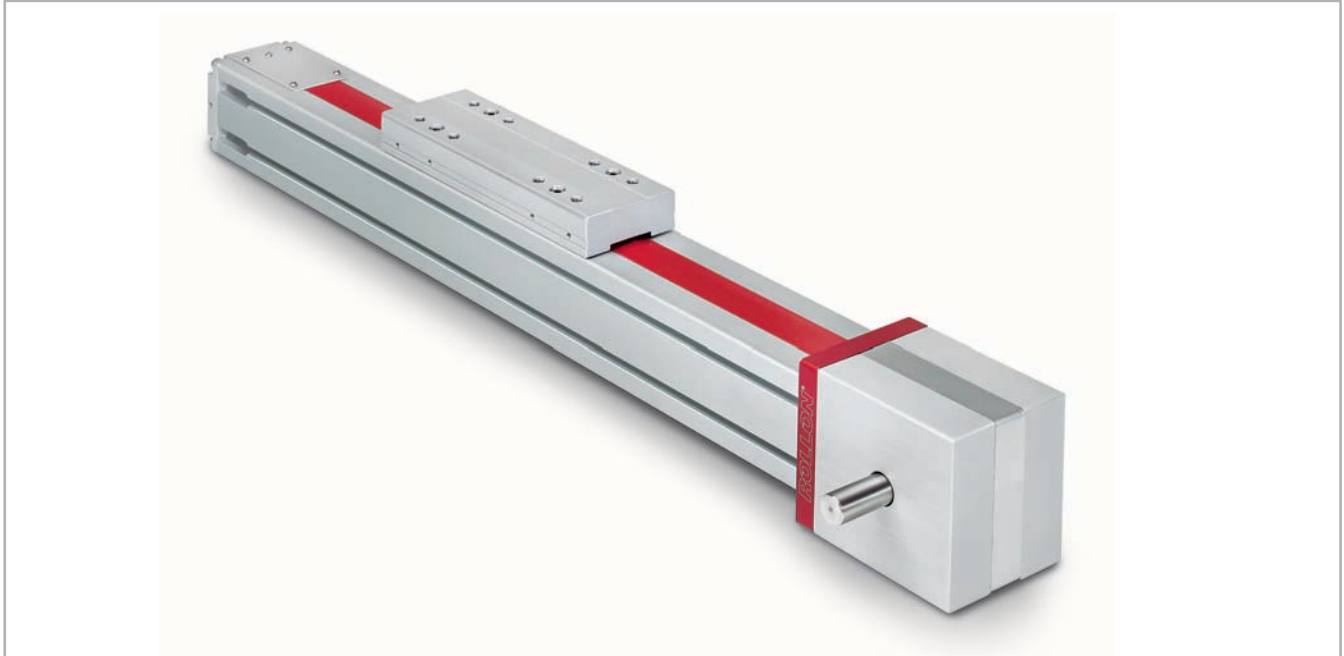
Special lubrications designed for use in cleanroom or vacuum environments are used for all bearings and linear rails.

> The components

Extruded bodies

The anodized aluminium extrusions used for the bodies of the Rollon ONE series linear units were designed and manufactured in cooperation with a leading company in this field to obtain the right combination of high mechanical strength and reduced weight. Aluminium alloy 6060 is used (see physical-chemical characteristics below). The dimensional tolerances comply with EN 755-9 standard.

Driving belt

ONE Series is the first linear units driven by timing belt capable to achieve ISO CLASS 3.

We are using selected high quality polyurethane timing belts, AT profile, manufactured by leading companies in this field.

Carriage

The carriage of the Rollon ONE series linear units are made entirely of anodized aluminum. Each carriage has mounting holes fitted with stainless steel thread inserts. Rollon offers multiple carriages to accommodate a vast array of applications. The unique design of the carriage allows for the sealing strip to pass through the carriage.

Sealing strip

Rollon ONE series linear units are equipped with a polyurethane sealing strip to prevent particles generated inside the unit to go outside. The sealing strip runs the length of the body and is kept in position by micro-bearings located with in the carriage. This minimizes frictional resistance as the strip passes through the carriage while providing maximum protection.

General data about aluminum used: AL 6060

Chemical composition [%]

Al	Mg	Si	Fe	Mn	Zn	Cu	Impurities
Remainder	0.35-0.60	0.30-0.60	0.30	0.10	0.10	0.10	0.05-0.15

Tab. 1

Physical characteristics

Density	Coeff. of elasticity	Coeff. of thermal expansion (20°-100°C)	Thermal conductivity (20°C)	Specific heat (0°-100°C)	Resistivity	Melting point
$\frac{\text{kg}}{\text{dm}^3}$	$\frac{\text{kN}}{\text{mm}^2}$	$\frac{10^{-6}}{\text{K}}$	$\frac{\text{W}}{\text{m} \cdot \text{K}}$	$\frac{\text{J}}{\text{kg} \cdot \text{K}}$	$\Omega \cdot \text{m} \cdot 10^{-9}$	°C
2.7	69	23	200	880-900	33	600-655

Tab. 2

Mechanical characteristics

Rm	Rp (02)	A	HB
$\frac{\text{N}}{\text{mm}^2}$	$\frac{\text{N}}{\text{mm}^2}$	%	—
205	165	10	60-80

Tab. 3

> The linear motion system

Certified Clean Room Class

ONE Series is a device tested by FRAUNHOFER IPA Institute - Stuttgart (D). Rollon achieved the ISO CLASS 3 (DIN EN ISO 14644-1) and CLASS 1 US FED STD 209E cleanroom standard using a combination of a vacuum pump and our special sealing belt (Intl. Patent Pending).

Vacuum system

The ONE series actuator has specific connection ports on the drive and the idle end of the unit to connect a vacuum system. The vacuum quality must be evaluated case by case, but Rollon has had success with 0,8 bar on a ONE 80 with a stroke of 1.000 mm up to 4.000 mm. A vacuum was used in conjunction to Rollon's special sealing strip to achieve ISO CLASS 3 (DIN EN ISO 14644-1) and CLASS 1 US FED STD 209E

Selected mechanical components

ONE Series is assembled with select high-quality components. Only Stainless Steel (AISI 303, AISI 440C) is used for bearings, linear guides, shafts, pulleys, and other metallic components. Where it is impossible to use Stainless Steel, Rollon provides a special treatment tested under severe conditions and under particle generation.

ONE SP section

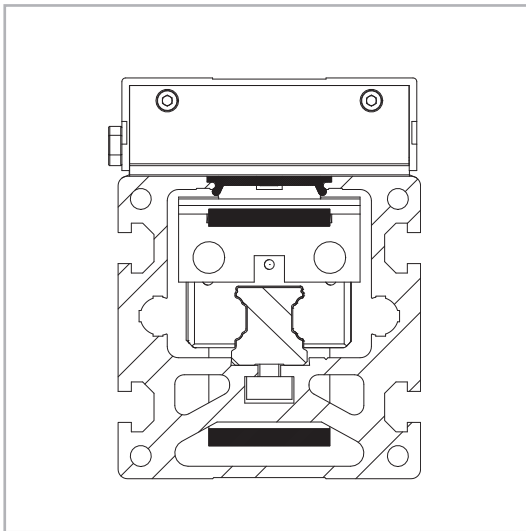

Fig. 2

Lubrication

ONE Series is equipped with "innovate and hi-tech linear guides" that feature special ball cages to maintain spacing. This feature supports a long-term maintenance and a low particle generation if combined with special lubricant, specifically developed and adopted for Clean Room applications.

Range

ONE Series is now available in 3 different sizes, for multi axes combinations:

- ONE 50
- ONE 80
- ONE 100

Maximum stroke is 6.000 mm, except ONE 50 where the maximum stroke is 3.700 mm.

For technical details and load capacities, please refer to next pages.



INTL. PATENT PENDING

> ONE 50

ONE 50 Dimension

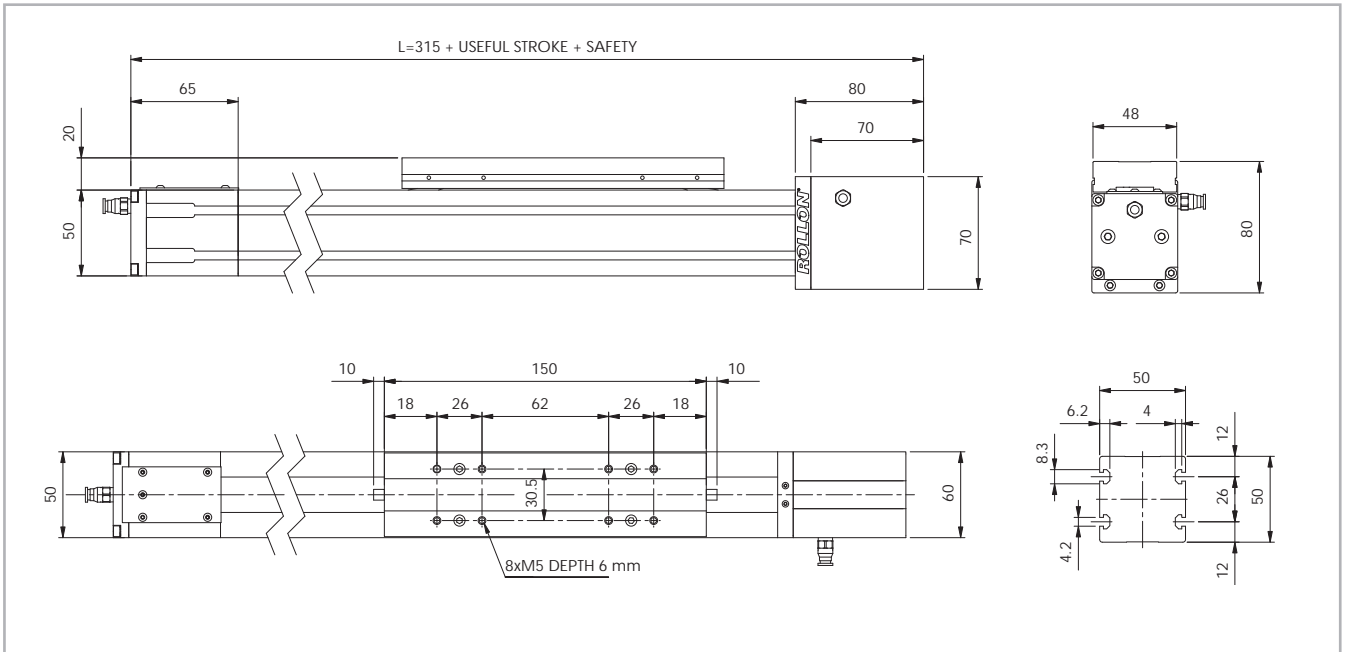

For further details please visit our website www.rollon.com and download the related DXF files.

Fig. 3

Technical data

	Type
	ONE 50
Max. useful stroke length [mm]	3700
Max. positioning repeatability [mm]*1	± 0.05
Max. speed [m/s]	4
Max. acceleration [m/s ²]	50
Type of belt	22 AT 5
Type of pulley	Z 23
Pulley pitch diameter [mm]	36,61
Carriage displacement per pulley turn [mm]	115
Carriage weight [kg]	0.4
Zero travel weight [kg]	1.8
Weight for 100 mm useful stroke [kg]	0.4
Starting torque [Nm]	0.4
Moment of inertia of pulleys [g mm ²]	19810

*1) Positioning repeatability is dependent on the type of transmission used

Tab. 4

Moments of inertia of the aluminum body

Type	I_x [10 ⁷ mm ⁴]	I_y [10 ⁷ mm ⁴]	I_p [10 ⁷ mm ⁴]
ONE 50	0.025	0.031	0.056

Tab. 5

Driving belt

The driving belt is manufactured from a friction resistant polyurethane and with steel cords for high tensile stress resistance.

Type	Type of belt	Belt width [mm]	Weight kg/m
ONE 50	22 AT 5	22	0.072

Tab. 6

Belt length (mm) = 2 x L - 130

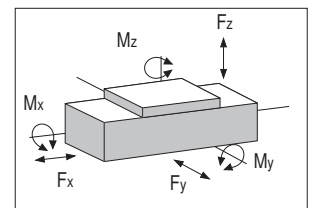

ONE 50 - Load capacity

Type	F_x [N]		F_y [N]		F_z [N]		M_x [Nm]		M_y [Nm]		M_z [Nm]	
	Stat.	Dyn.	Stat.	Dyn.	Stat.	Dyn.	Stat.	Dyn.	Stat.	Dyn.	Stat.	Dyn.
ONE 50	809	508	7000	4492	7000	4492	42	27	231	148	231	148

See verification under static load and lifetime on page SL-2 and SL-3

Tab. 7

> ONE 80

ONE 80 Dimension

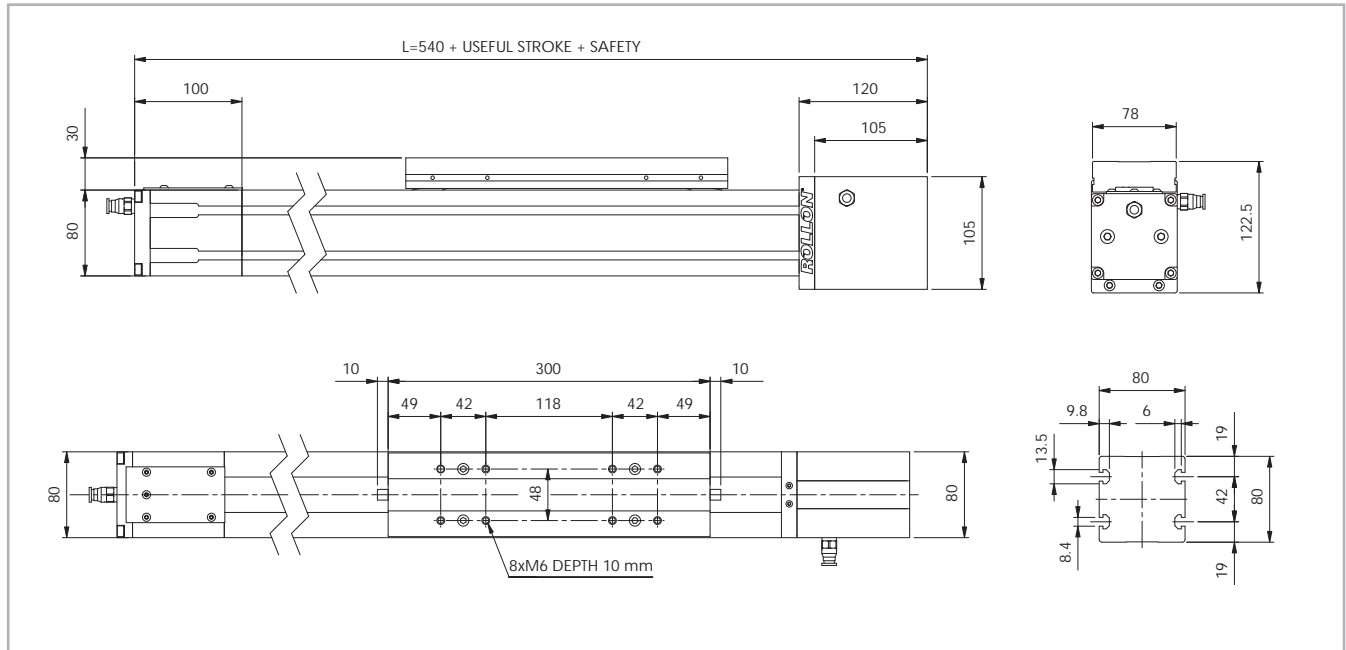

For further details please visit our website www.rollon.com and download the related DXF files.

Fig. 4

Technical data

	Type
	ONE 80
Max. useful stroke length [mm]	6000
Max. positioning repeatability [mm]*1	± 0.05
Max. speed [m/s]	5
Max. acceleration [m/s ²]	50
Type of belt	32 AT 10
Type of pulley	Z 19
Pulley pitch diameter [mm]	60.48
Carriage displacement per pulley turn [mm]	190
Carriage weight [kg]	2.7
Zero travel weight [kg]	10.5
Weight for 100 mm useful stroke [kg]	1
Starting torque [Nm]	2.2
Moment of inertia of pulleys [g mm ²]	388075

*1) Positioning repeatability is dependant on the type of transmission used

Tab. 8

Moments of inertia of the aluminum body

Type	I_x [10 ⁷ mm ⁴]	I_y [10 ⁷ mm ⁴]	I_p [10 ⁷ mm ⁴]
ONE 80	0.136	0.195	0.331

Tab. 9

Driving belt

The driving belt is manufactured from a friction resistant polyurethane and with steel cords for high tensile stress resistance.

Type	Type of belt	Belt width [mm]	Weight kg/m
ONE 80	32 AT 10	32	0.185

Tab. 10

Belt length (mm) = 2 x L - 230

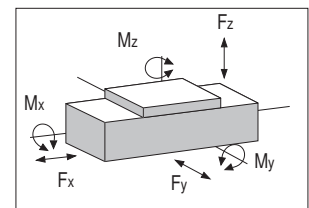

ONE 80 - Load capacity

Type	F_x [N]		F_y [N]		F_z [N]		M_x [Nm]		M_y [Nm]		M_z [Nm]	
	Stat.	Dyn.	Stat.	Dyn.	Stat.	Dyn.	Stat.	Dyn.	Stat.	Dyn.	Stat.	Dyn.
ONE 80	2013	1170	38480	21735	46176	25875	398	223	3371	1889	2809	1587

See verification under static load and lifetime on page SL-2 and SL-3

Tab. 11

> ONE 110

ONE 110 Dimension

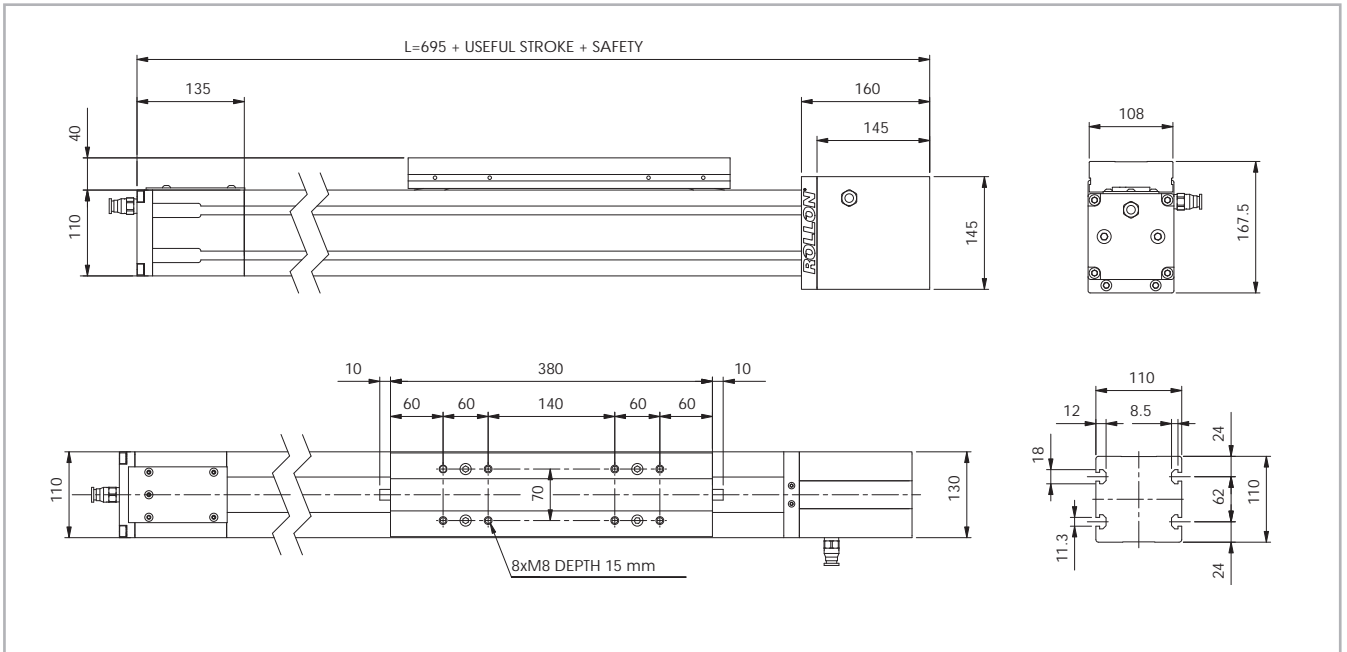

For further details please visit our website www.rollon.com and download the related DXF files.

Fig. 5

Technical data

	Type
	ONE 110
Max. useful stroke length [mm]	6000
Max. positioning repeatability [mm]*1	± 0.05
Max. speed [m/s]	5
Max. acceleration [m/s ²]	50
Type of belt	50 AT 10
Type of pulley	Z 27
Pulley pitch diameter [mm]	85.94
Carriage displacement per pulley turn [mm]	270
Carriage weight [kg]	5.6
Zero travel weight [kg]	22.5
Weight for 100 mm useful stroke [kg]	1.4
Starting torque [Nm]	3.5
Moment of inertia of pulleys [g mm ²]	2.193 · 10 ⁶

*1) Positioning repeatability is dependent on the type of transmission used

Tab. 12

Moments of inertia of the aluminum body

Type	I_x [10 ⁷ mm ⁴]	I_y [10 ⁷ mm ⁴]	I_p [10 ⁷ mm ⁴]
ONE 110	0.446	0.609	1.054

Tab. 13

Driving belt

The driving belt is manufactured from a friction resistant polyurethane and with steel cords for high tensile stress resistance.

Type	Type of belt	Belt width [mm]	Weight kg/m
ONE 110	50 AT 10	50	0.290

Tab. 14

Belt length (mm) = 2 x L - 290

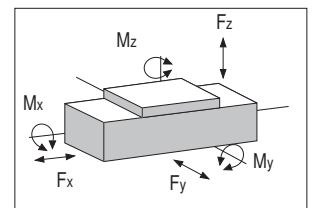

ONE 110 - Load capacity

Type	F_x [N]		F_y [N]		F_z [N]		M_x [Nm]		M_y [Nm]		M_z [Nm]	
	Stat.	Dyn.	Stat.	Dyn.	Stat.	Dyn.	Stat.	Dyn.	Stat.	Dyn.	Stat.	Dyn.
ONE 110	4440	2940	92300	46003	110760	54765	1110	549	9968	4929	8307	4140

See verification under static load and lifetime on page SL-2 and SL-3

Tab. 15

> Planetary gears

Assembly to the right or to the left of the driving head

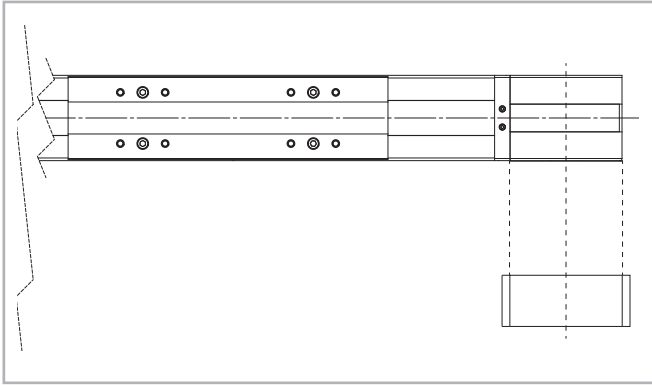
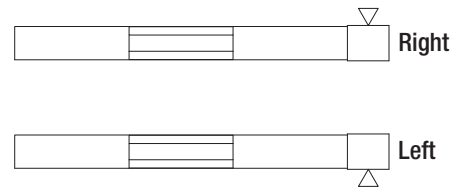

Fig. 6

The series ONE linear units can be fitted with several different drive systems. In each case, the driving pulley is attached to the reduction gearshaft by means of a tapered coupling to ensure high accuracy over a long period of time.

Versions with planetary gears

Planetary gears are used for highly dynamic robot, automation and handling applications involving stressing cycles and with high level precision requirements. Standard models are available with clearance from 3' to 15' and with a reduction ratio from 1:3 to 1:1000. For assembly of non-standard planetary gear, contact our offices.



Shaft with centering

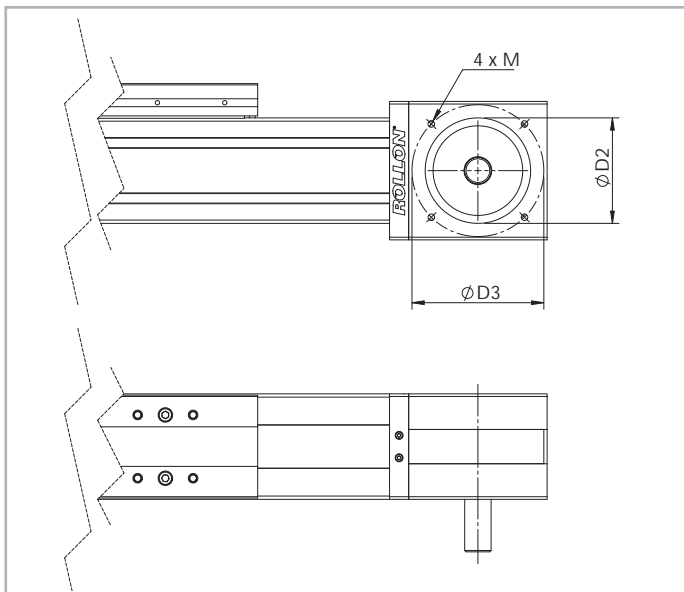

Fig. 7

Unit	Shaft type	D2	D3	M	Head code AS left	Head code AS right
ONE 50	AS 12	55	70	M5	VB	VA
ONE 80	AS 20	80	100	M6	VB	VA
ONE 110	AS 25	110	130/160	M8	VB	VA

Tab. 16

> Accessories

Fixing by brackets

The linear motion systems used for the Rollon series ONE linear units enables them to support loads in any direction. They can therefore be installed in any position.

To install the units, we recommend the use of the dedicated T-Slots in the extruded bodies as shown below.

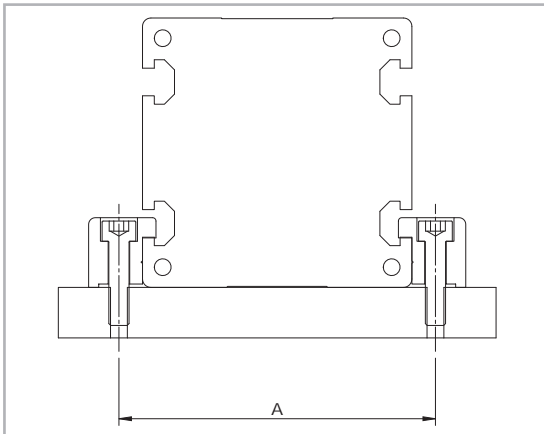

Fig. 8

Unit	A (mm)
ONE 50	62
ONE 80	94
ONE 110	130

Tab. 17

Warning:

Do not fix the linear units through the drive ends.

Fixing brackets

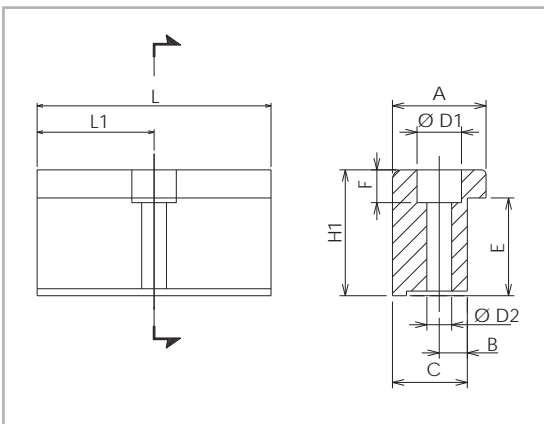

Fig. 9

Dimensions (mm)

Unit	A	H1	B	C	E	F	D1	D2	L	L1	Code
ONE 50	20	14	6	16	10	6	10	5.5	35	17.5	1000958
ONE 80	20	20.7	7	16	14.7	7	11	6.4	50	25	1001491
ONE 110	36.5	28.5	10	31	18.5	11.5	16.5	10.5	100	50	1001233

Tab. 18

Fixing bracket

Anodized aluminum block for fixing the linear units through the side T-Slots of the body.

T-Nuts

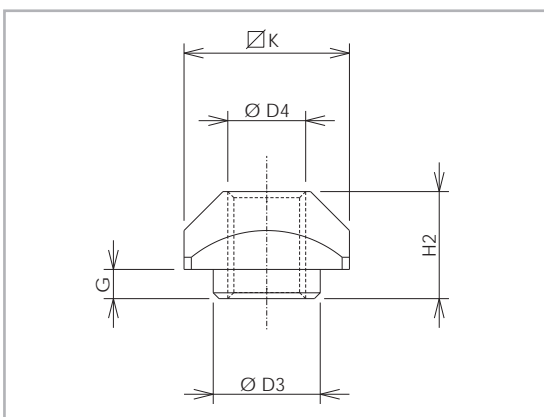

Fig. 10

Dimensions (mm)

Unit	D3	D4	G	H2	K	Code
ONE 50	-	M4	-	3.4	8	1001046
ONE 80	8	M6	3.3	8.3	13	1000043
ONE 110	11	M8	2.8	10.8	17	1000932

Tab. 19

T-nuts

Steel nuts to be used in the slots of the body.

Proximity

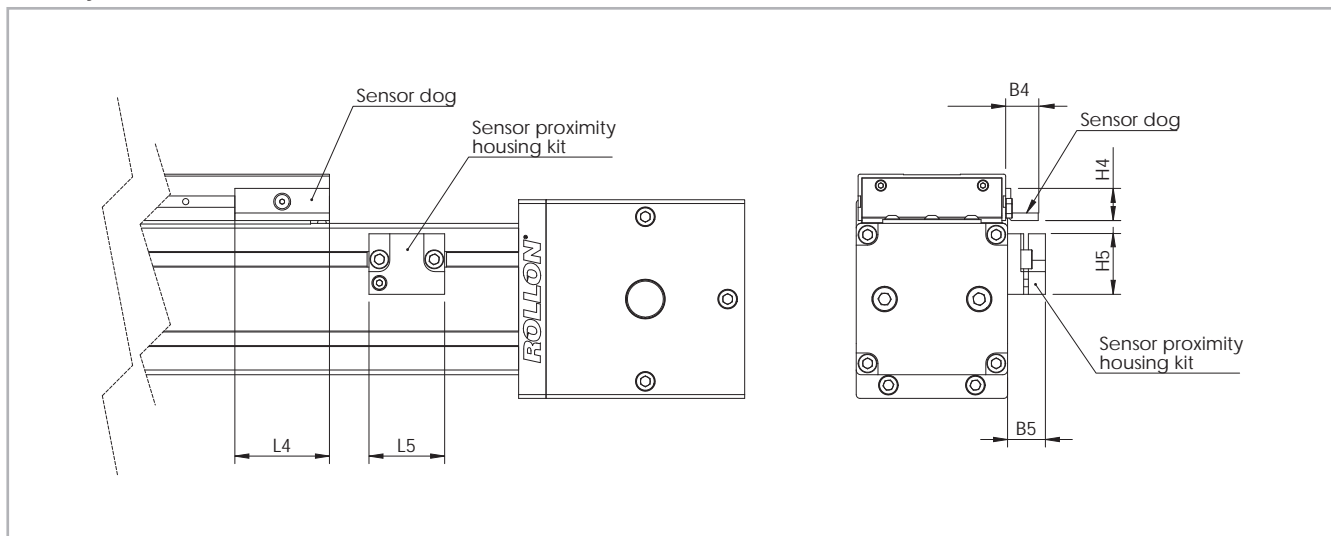

Fig. 11

Sensor proximity housing kit

Red anodized aluminum sensor holder, equipped with T-nuts for fixing onto the profile.

Sensor dog

L-shaped bracket in zinc-plated iron, mounted on the carriage and used for proximity switch operations.

Dimensions (mm)

Unit	B4	B5	L4	L5	H4	H5	For proximity	Sensor dog code	Sensor proximity housing kit code
ONE 50	9.5	14	25	29	11.9	22.5	Ø 8	G000268	G000211
ONE 80	17.2	20	50	40	17	32	Ø 12	G000267	G000209
ONE 110	17.2	20	50	40	17	32	Ø 12	G000267	G000210

Tab. 20

Ordering key



> Identification codes for the ONE linear unit

N	08 05=50 08=80 10=100	VA	02000	3B	
					SP stainless steel <i>see pg. CRS-3</i>
					L= total length of the unit
					Driving head code <i>see pg. CRS-8</i>
					Linear unit size <i>see from pg. CRS-5 to pg. CRS-7</i>
					ONE Series <i>see pg. CRS-2</i>

In order to create identification codes for Actuator Line, you can visit: <http://configureactuator.rollon.com>

ROLLON[®]
Linear Evolution

Smart System

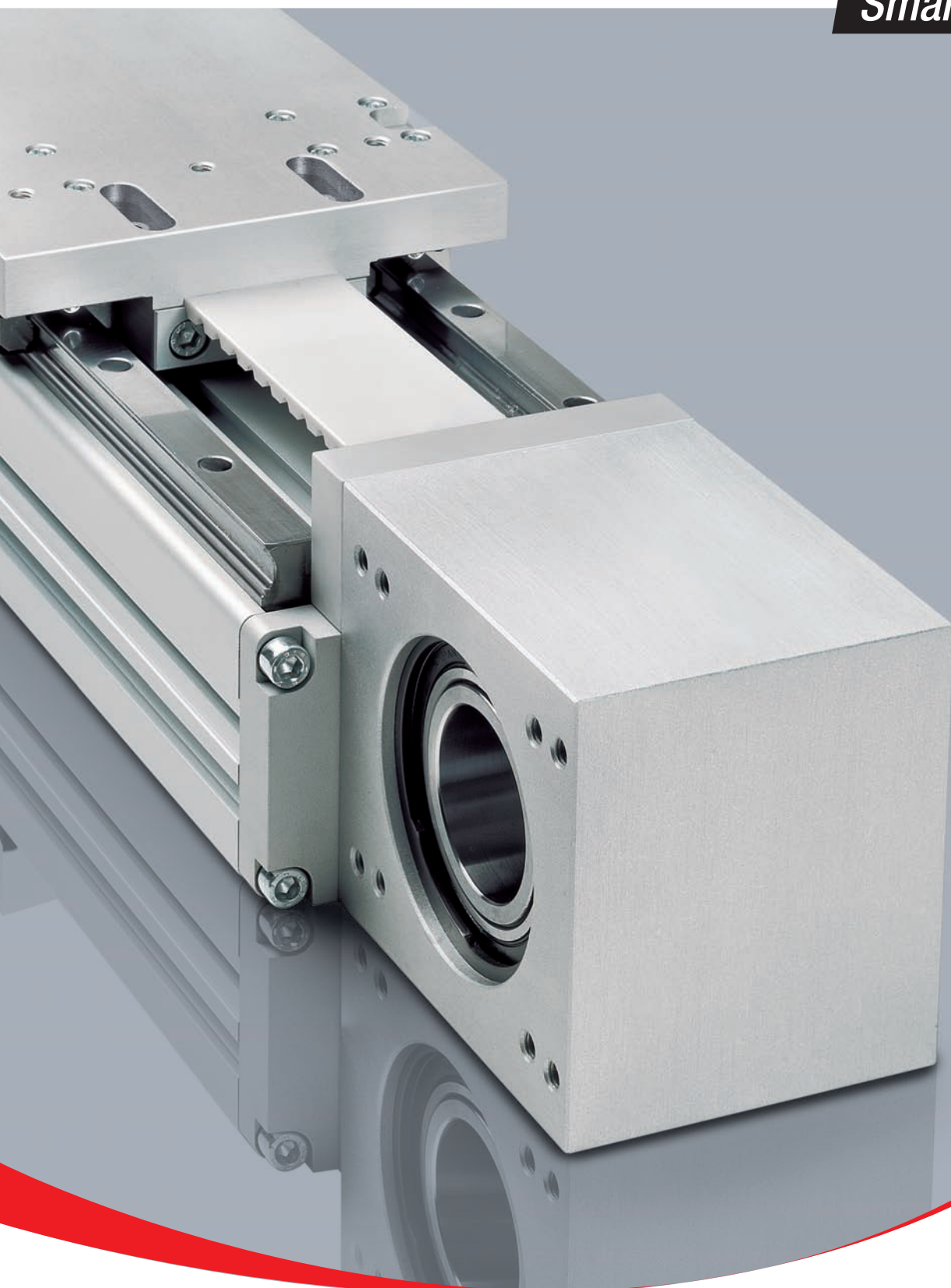

E-SMART series



> E-SMART series description

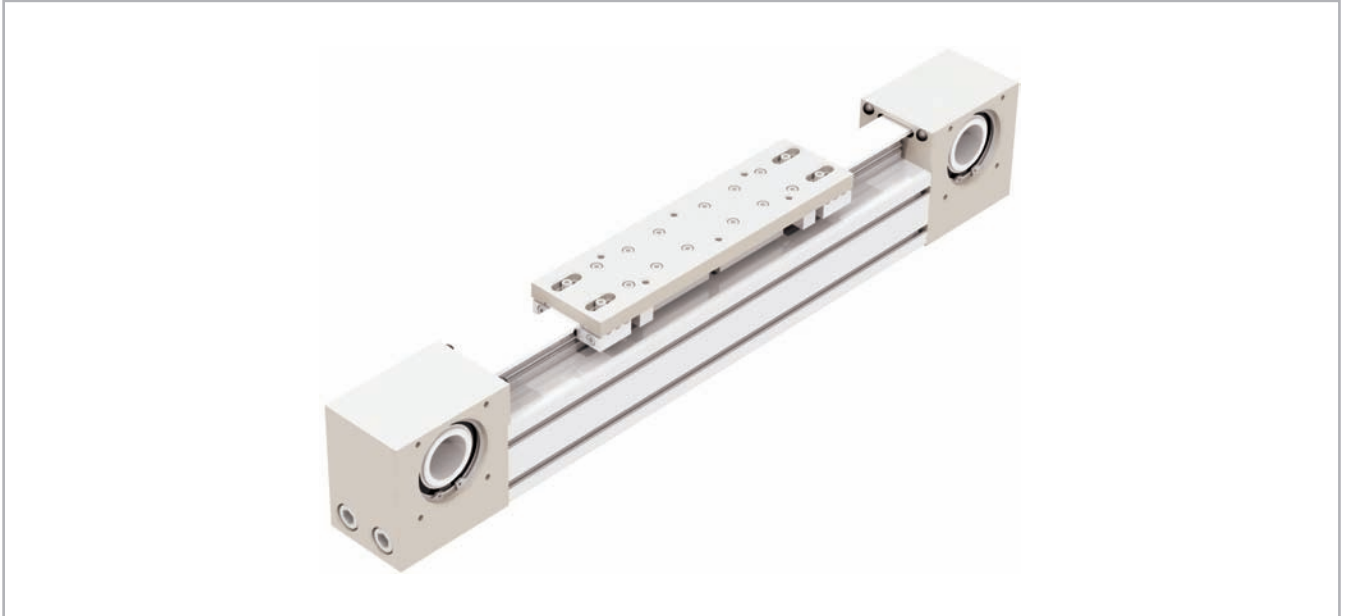

Fig. 1

E-SMART

The E-SMART series linear units have an extruded and anodized aluminum self-supporting structure with a profile available in four sizes from 30 to 100mm. Transmission is achieved with a polyurethane steel reinforced driving belt. Also featured is a single rail with one or more recirculating ball bearing runner blocks.

> The components

Extruded bodies

The anodized aluminum extrusions used for the bodies of the Rollon SMART series linear units were designed and manufactured in cooperation with a leading company in this field to obtain the right combination of high mechanical strength and reduced weight. The anodized aluminum alloy 6060 used (see physical chemical characteristics below for further information) was extruded with dimensional tolerances complying with EN 755-9 standards.

Driving belt

The Rollon SMART series linear units use steel reinforced polyurethane drive belts with AT pitch. This type of belt is ideal due to its high load trans-

mission characteristics, compact size, and low noise. Used in conjunction with a backlash-free pulley, smooth alternating motion can be achieved. Optimization of the maximum belt width/body dimension ratio enables the following performance characteristics to be achieved:

- High speed
- Low noise
- Low wear

Carriage

The carriage of the Rollon SMART series linear units is made entirely of machined anodized aluminum. The dimensions vary depending on the type. Rollon offers multiple carriages to accommodate a vast array of applications.

General data about aluminum used: AL 6060

Chemical composition [%]

Al	Mg	Si	Fe	Mn	Zn	Cu	Impurites
Remainder	0.35-0.60	0.30-0.60	0.30	0.10	0.10	0.10	0.05-0.15

Tab. 1

Physical characteristics

Density	Coeff. of elasticity	Coeff. of thermal expansion (20°-100°C)	Thermal conductivity (20°C)	Specific heat (0°-100°C)	Resistivity	Melting point
$\frac{\text{kg}}{\text{dm}^3}$	$\frac{\text{kN}}{\text{mm}^2}$	$\frac{10^{-6}}{\text{K}}$	$\frac{\text{W}}{\text{m} \cdot \text{K}}$	$\frac{\text{J}}{\text{kg} \cdot \text{K}}$	$\Omega \cdot \text{m} \cdot 10^{-9}$	°C
2.7	70	23.8	200	880-900	33	600-655

Tab. 2

Mechanical characteristics

Rm	Rp (02)	A	HB
$\frac{\text{N}}{\text{mm}^2}$	$\frac{\text{N}}{\text{mm}^2}$	%	—
250	200	10	75

Tab. 3

> The linear motion system

The linear motion system has been designed to meet the load capacity, speed, and maximum acceleration conditions of a wide variety of applications.

Performance characteristics:

- The ball bearing guides with high load capacity are mounted in a dedicated seat on the aluminum body.
- The carriage of the linear unit is assembled on preloaded ball bearing blocks that enables the carriage to withstand loading in the four main directions.
- The ball bearing carriages of the SP versions are also fitted with a retention cage that eliminates "steel-steel" contact between adjacent revolving parts and prevents misalignment.
- The blocks have seals on both sides and, when necessary, an additional scraper can be fitted for very dusty conditions.

The linear motion system described above offers:

- High speed and acceleration
- High load capacity
- High permissible bending moments
- Low friction
- Long life
- Low noise

E-SMART section

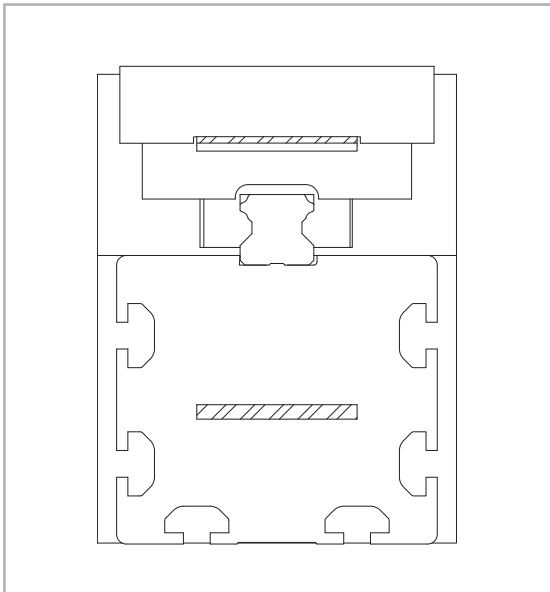
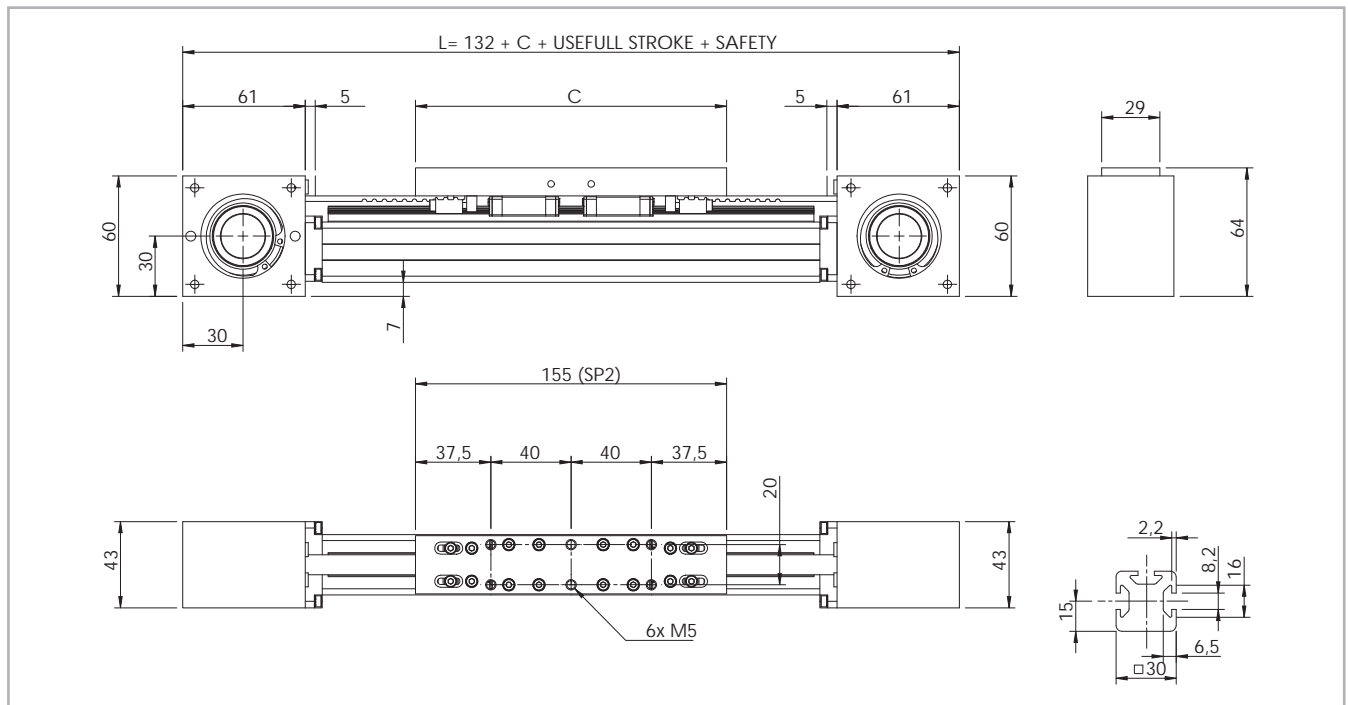

Fig. 2

> E-SMART 30 SP2

E-SMART 30 Dimensions



* The length of the safety stroke is provided on request according to the customer's specific requirements.

Fig. 3

Technical data

	Type
	E-SMART 30 SP2
Max. useful stroke length [mm]	3700
Max. positioning repeatability [mm]*1	± 0.05
Max. speed [m/s]	4.0
Max. acceleration [m/s ²]	50
Type of belt	10 AT 5
Type of pulley	Z 24
Pulley pitch diameter [mm]	38.2
Carriage displacement per pulley turn [mm]	120
Carriage weight [kg]	0.28
Zero travel weight [kg]	1.83
Weight for 100 mm useful stroke [kg]	0.16
Starting torque [Nm]	0.15
Moment of inertia of pulleys [g · mm ²]	57.630

*1) Positioning repeatability is dependent on the type of transmission used.

Tab. 4

E-SMART 30 - Load capacity

Type	F _x [N]		F _y [N]		F _z [N]		M _x [Nm]		M _y [Nm]		M _z [Nm]	
	Stat.	Dyn.	Stat.	Dyn.	Stat.	Dyn.	Stat.	Dyn.	Stat.	Dyn.	Stat.	Dyn.
E-SMART 30 SP2	385	242	6930	4616	6930	4616	43	29	132	88	132	88

See verification under static load and lifetime on page SL-2 and SL-3

Tab. 7

Moments of inertia of the aluminum body

Type	I _x [10 ⁷ mm ⁴]	I _y [10 ⁷ mm ⁴]	I _p [10 ⁷ mm ⁴]
E-SMART 30 SP2	0.003	0.003	0.007

Tab. 5

Driving belt

The driving belt is manufactured from a friction resistant polyurethane and with steel cords for high tensile stress resistance.

Type	Type of belt	Belt width [mm]	Weight [kg/m]
E-SMART 30 SP2	10 AT 5	10	0.033

Tab. 6

$$\text{Belt length (mm)} = 2 \times L - 100 \text{ (SP2)}$$

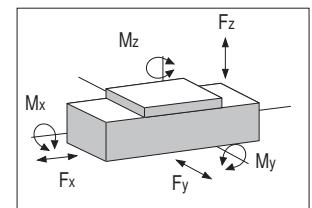

> E-SMART 50 SP1 - SP2 - SP3

E-SMART 50 Dimensions

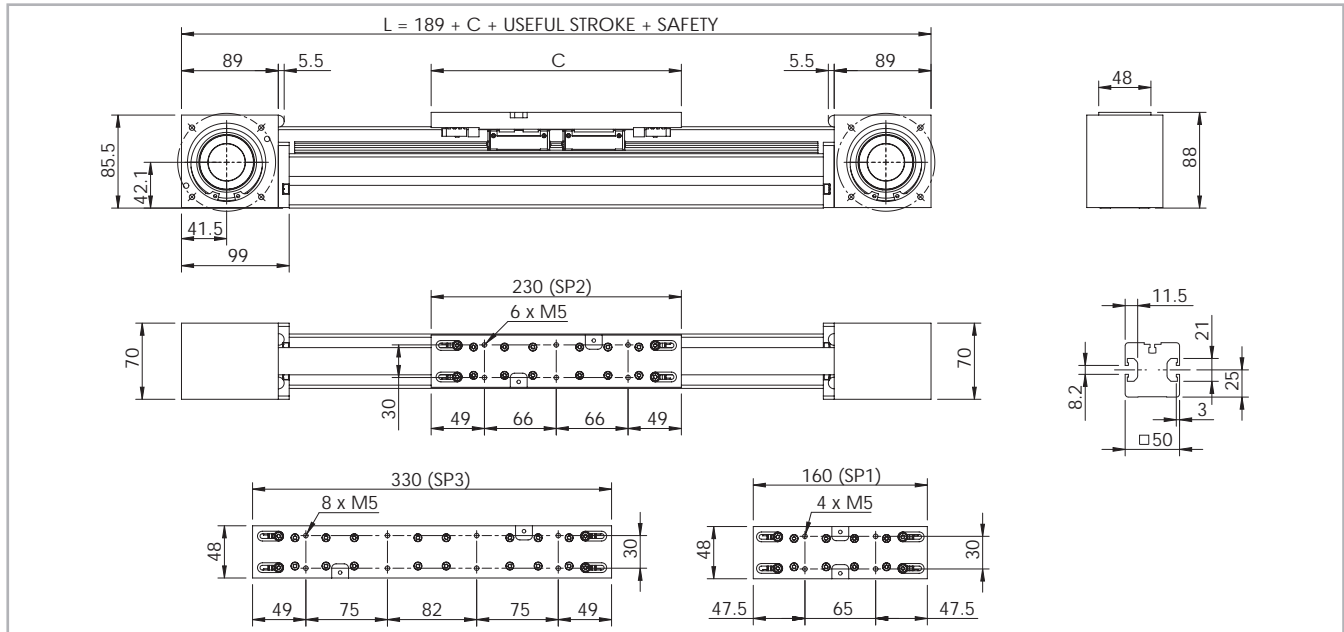

* The length of the safety stroke is provided on request according to the customer's specific requirements.

Fig. 4

Technical data

	Type		
	E-SMART 50 SP1	E-SMART 50 SP2	E-SMART 50 SP3
Max. useful stroke length [mm]*1	6120	6050	5950
Max. positioning repeatability [mm]*2	± 0.05	± 0.05	± 0.05
Max. speed [m/s]	4.0	4.0	4.0
Max. acceleration [m/s ²]	50	50	50
Type of belt	25 AT 5	25 AT 5	25 AT 5
Type of pulley	Z 40	Z 40	Z 40
Pulley pitch diameter [mm]	63.66	63.66	63.66
Carriage displacement per pulley turn [mm]	200	200	200
Carriage weight [kg]	0.54	0.85	1.21
Zero travel weight [kg]	4.89	5.4	6.16
Weight for 100 mm useful stroke [kg]	0.34	0.34	0.34
Starting torque [Nm]	0.35	0.345	0.55
Moment of inertia of pulleys [g · mm ²]	891.270	891.270	891.270

*1) It is possible to obtain stroke up to 11.270 (SP1), 11.200 (SP2), 11.100 (SP3) by means of special Rollon joints. Tab. 8

*2) Positioning repeatability is dependent on the type of transmission used.

Moments of inertia of the aluminum body

Type	I_x [10 ⁷ mm ⁴]	I_y [10 ⁷ mm ⁴]	I_p [10 ⁷ mm ⁴]
E-SMART 50 SP	0.021	0.020	0.041

Tab. 9

Driving belt

The driving belt is manufactured from a friction resistant polyurethane and with steel cords for high tensile stress resistance.

Type	Type of belt	Belt width [mm]	Weight [kg/m]
E-SMART 50 SP	25 AT 5	25	0.080

Tab. 10

$$\begin{aligned} \text{Belt length (mm)} &= 2 \times L - 60 \text{ (SP1)} \\ &= 2 \times L - 125 \text{ (SP2)} \\ &= 2 \times L - 225 \text{ (SP3)} \end{aligned}$$

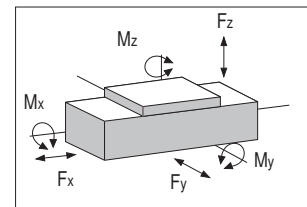

E-SMART 50 - Load capacity

Type	F_x [N]		F_y [N]		F_z [N]		M_x [Nm]		M_y [Nm]		M_z [Nm]	
	Stat.	Dyn.	Stat.	Dyn.	Stat.	Dyn.	Stat.	Dyn.	Stat.	Dyn.	Stat.	Dyn.
E-SMART 50 SP1	1050	750	15280	9945	15280	9945	120	78	90	59	90	59
E-SMART 50 SP2	1050	750	30560	19890	30560	19890	240	156	856	557	856	557
E-SMART 50 SP3	1050	750	45840	29835	45840	29835	360	234	2582	1681	2582	1681

See verification under static load and lifetime on page SL-2 and SL-3

Tab. 11

> E-SMART 80 SP1 - SP2

E-SMART 80 Dimensions

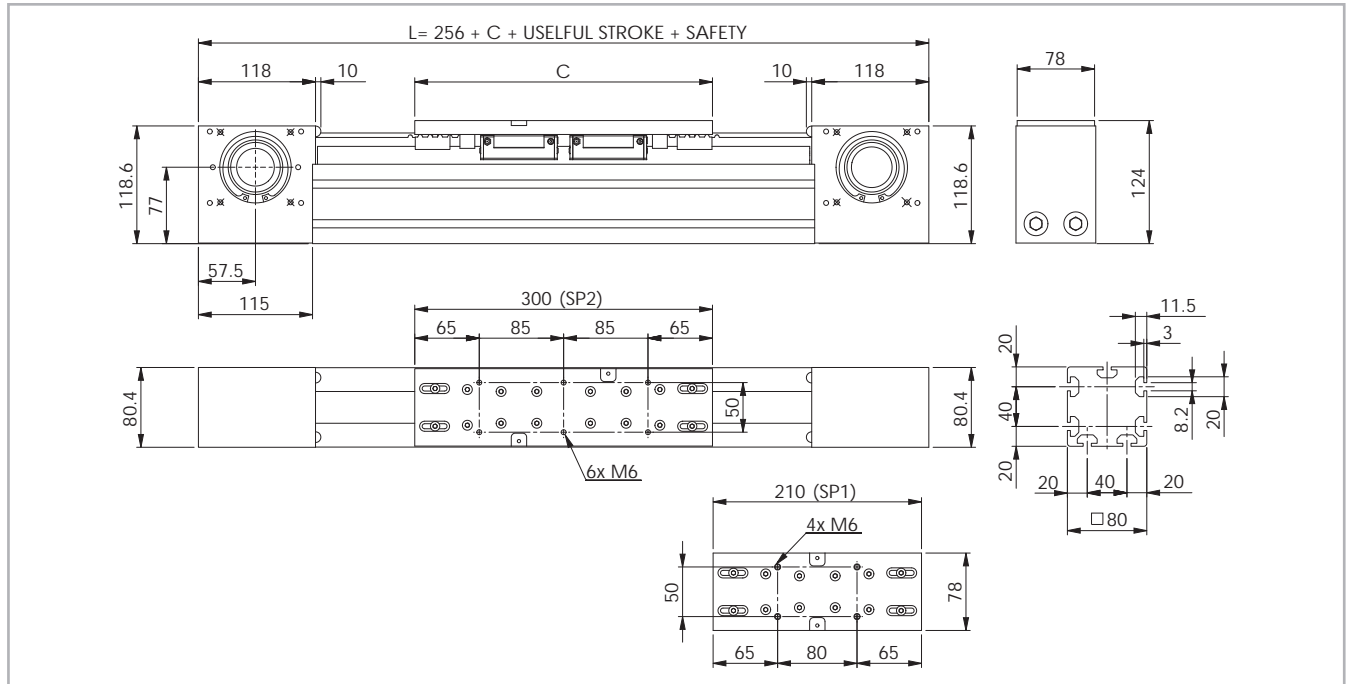

* The length of the safety stroke is provided on request according to the customer's specific requirements.

Fig. 5

Technical data

	Type	
	E-SMART 80 SP1	E-SMART 80 SP2
Max. useful stroke length [mm]*1	6060	5970
Max. positioning repeatability [mm]*2	± 0.05	± 0.05
Max. speed [m/s]	4.0	4.0
Max. acceleration [m/s ²]	50	50
Type of belt	32 AT 10	32 AT 10
Type of pulley	Z 21	Z 21
Pulley pitch diameter [mm]	66,84	66,84
Carriage displacement per pulley turn [mm]	210	210
Carriage weight [kg]	1.34	1.97
Zero travel weight [kg]	9.94	11.31
Weight for 100 mm useful stroke [kg]	0.76	0.76
Starting torque [Nm]	0.95	1.3
Moment of inertia of pulleys [g · mm ²]	938.860	938.860

*1) It is possible to obtain stroke up to 11.190 (SP1), 11.100 (SP2) by means of special Rollon joints.

*2) Positioning repeatability is dependent on the type of transmission used.

Tab. 12

E-SMART 80 - Load capacity

Type	F _x [N]		F _y [N]		F _z [N]		M _x [Nm]		M _y [Nm]		M _z [Nm]	
	Stat.	Dyn.	Stat.	Dyn.	Stat.	Dyn.	Stat.	Dyn.	Stat.	Dyn.	Stat.	Dyn.
E-SMART 80 SP1	2250	1459	25630	18318	25630	18318	260	186	190	136	190	136
E-SMART 80 SP2	2250	1459	51260	36637	51260	36637	520	372	1874	1339	1874	1339

See verification under static load and lifetime on page SL-2 and SL-3

Tab. 15

Moments of inertia of the aluminum body

Type	I _x [10 ⁷ mm ⁴]	I _y [10 ⁷ mm ⁴]	I _p [10 ⁷ mm ⁴]
E-SMART 80 SP	0.143	0.137	0.280

Tab. 13

Driving belt

The driving belt is manufactured from a friction resistant polyurethane and with steel cords for high tensile stress resistance.

Type	Type of belt	Belt width [mm]	Weight [kg/m]
E-SMART 80 SP	32 AT 10	32	0.186

Tab. 14

Belt length (mm) = 2 x L - 135 (SP1)
2 x L - 225 (SP2)

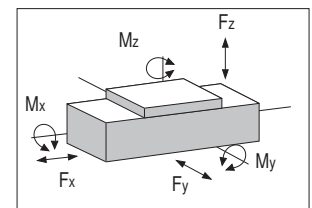

> E-SMART 80 SP3 - SP4

E-SMART 80 Dimensions

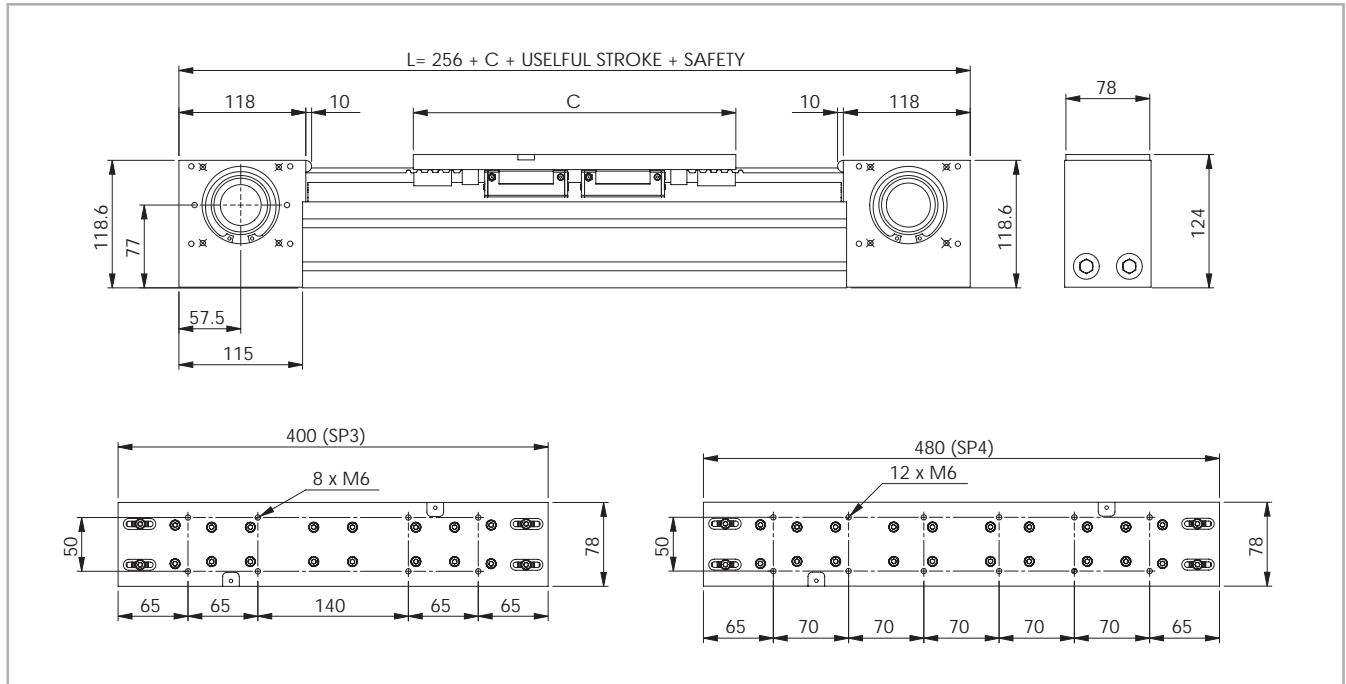

* The length of the safety stroke is provided on request according to the customer's specific requirements.

Fig. 6

Technical data

	Type	
	E-SMART 80 SP3	E-SMART 80 SP4
Max. useful stroke length [mm]*1	5870	5790
Max. positioning repeatability [mm]*2	± 0.05	± 0.05
Max. speed [m/s]	4.0	4.0
Max. acceleration [m/s ²]	50	50
Type of belt	32 AT 10	32 AT 10
Type of pulley	Z 21	Z 21
Pulley pitch diameter [mm]	66,84	66,84
Carriage displacement per pulley turn [mm]	210	210
Carriage weight [kg]	2.63	3.23
Zero travel weight [kg]	12.83	14.06
Weight for 100 mm useful stroke [kg]	0.76	0.76
Starting torque [Nm]	1.4	1.52
Moment of inertia of pulleys [g · mm ²]	938.860	938.860

*1) It is possible to obtain stroke up to 11.000 (SP3), 10.920 (SP4) by means of special Rollon joints.

*2) Positioning repeatability is dependent on the type of transmission used.

Tab. 16

E-SMART 80 - Load capacity

Type	F _x [N]		F _y [N]		F _z [N]		M _x [Nm]		M _y [Nm]		M _z [Nm]	
	Stat.	Dyn.	Stat.	Dyn.	Stat.	Dyn.	Stat.	Dyn.	Stat.	Dyn.	Stat.	Dyn.
E-SMART 80 SP3	2250	1459	76890	54956	76890	54956	780	557	4870	3481	4870	3481
E-SMART 80 SP4	2250	1459	102520	73274	102520	73274	1040	743	7689	5496	7689	5496

See verification under static load and lifetime on page SL-2 and SL-3

Tab. 19

Moments of inertia of the aluminum body

Type	I _x [10 ⁷ mm ⁴]	I _y [10 ⁷ mm ⁴]	I _p [10 ⁷ mm ⁴]
E-SMART 80 SP	0.143	0.137	0.280

Tab. 17

Driving belt

The driving belt is manufactured from a friction resistant polyurethane and with steel cords for high tensile stress resistance.

Type	Type of belt	Belt width [mm]	Weight [kg/m]
E-SMART 80 SP	32 AT 10	32	0.186

Tab. 18

Belt length (mm) = 2 x L - 325 (SP3)
2 x L - 405 (SP4)

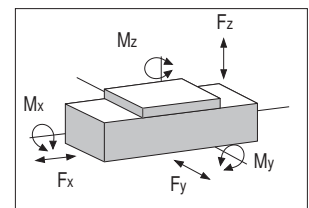

> E-SMART 100 SP1 - SP2

E-SMART 100 Dimensions

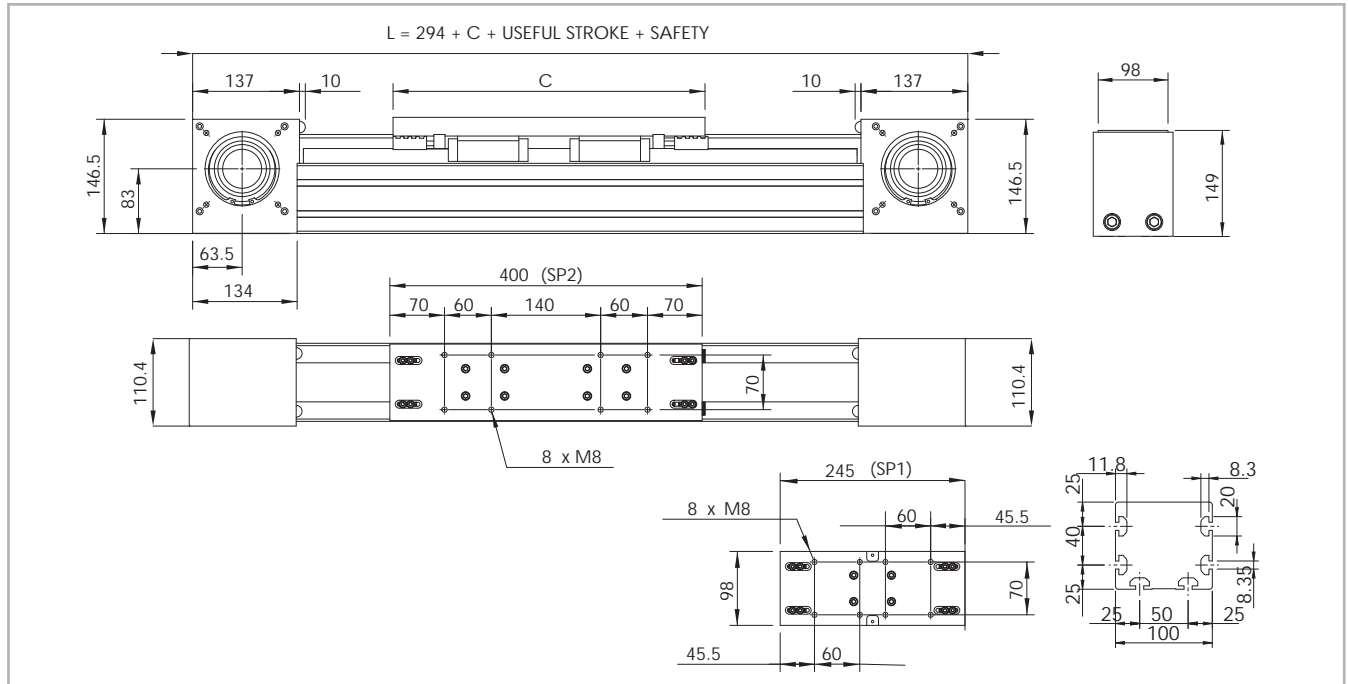

* The length of the safety stroke is provided on request according to the customer's specific requirements.

Fig. 7

Technical data

	Type	
	E-SMART 100 SP1	E-SMART 100 SP2
Max. useful stroke length [mm]*1	6025	5870
Max. positioning repeatability [mm]*2	± 0.05	± 0.05
Max. speed [m/s]	4.0	4.0
Max. acceleration [m/s ²]	50	50
Type of belt	50 AT 10	50 AT 10
Type of pulley	Z 27	Z 27
Pulley pitch diameter [mm]	85.94	85.94
Carriage displacement per pulley turn [mm]	270	270
Carriage weight [kg]	2.72	4.42
Zero travel weight [kg]	18.86	22.38
Weight for 100 mm useful stroke [kg]	1.3	1.3
Starting torque [Nm]	2.1	2.4
Moment of inertia of pulleys [g · mm ²]	4.035.390	4.035.390

*1) It is possible to obtain stroke up to 11.155 (SP1), 11.000 (SP2) by means of special Rollon joints.

*2) Positioning repeatability is dependent on the type of transmission used.

Tab. 20

E-SMART 100 Load capacity

Type	F _x [N]		F _y [N]		F _z [N]		M _x [Nm]		M _y [Nm]		M _z [Nm]	
	Stat.	Dyn.	Stat.	Dyn.	Stat.	Dyn.	Stat.	Dyn.	Stat.	Dyn.	Stat.	Dyn.
E-SMART 100 SP1	4440	3060	43620	31192	43620	31192	500	358	450	322	450	322
E-SMART 100 SP2	4440	3060	87240	62385	87240	62385	1000	715	5527	3952	5527	3952

See verification under static load and lifetime on page SL-2 and SL-3

Tab. 23

Moments of inertia of the aluminum body

Type	I _x [10 ⁷ mm ⁴]	I _y [10 ⁷ mm ⁴]	I _p [10 ⁷ mm ⁴]
E-SMART 100 SP	0.247	0.316	0.536

Tab. 21

Driving belt

The driving belt is manufactured from a friction resistant polyurethane and with steel cords for high tensile stress resistance.

Type	Type of belt	Belt width [mm]	Weight [kg/m]
E-SMART 100 SP	50 AT 10	50	0.290

Tab. 22

Belt length (mm) = 2 x L - 120 (SP1)
2 x L - 275 (SP2)

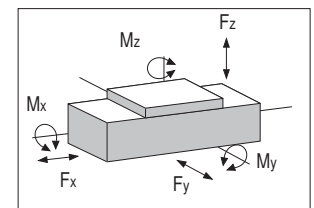

> E-SMART 100 SP3 - SP4

E-SMART 100 Dimensions

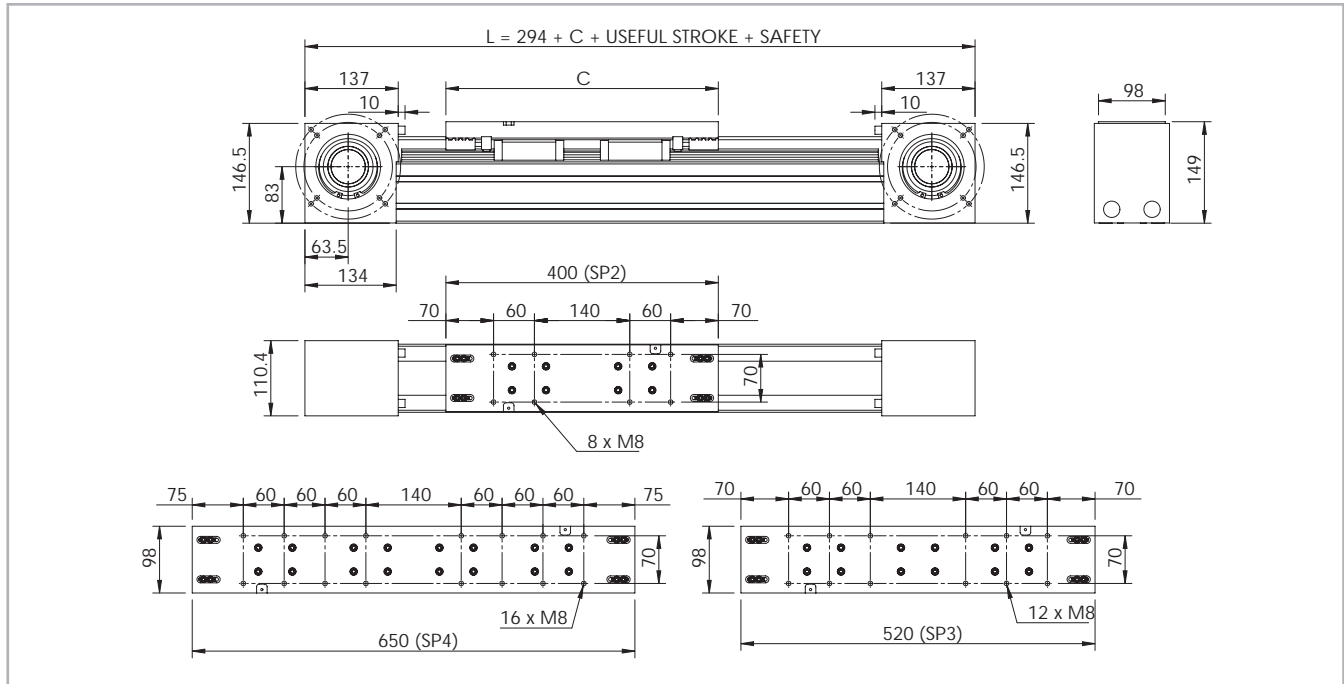

* The length of the safety stroke is provided on request according to the customer's specific requirements.

Fig. 8

Technical data

	Type	
	E-SMART 100 SP3	E-SMART 100 SP4
Max. useful stroke length [mm]*1	5790	5620
Max. positioning repeatability [mm]*2	± 0.05	± 0.05
Max. speed [m/s]	4.0	4.0
Max. acceleration [m/s ²]	50	50
Type of belt	50 AT 10	50 AT 10
Type of pulley	Z 27	Z 27
Pulley pitch diameter [mm]	85.94	85.94
Carriage displacement per pulley turn [mm]	270	270
Carriage weight [kg]	5.85	7.34
Zero travel weight [kg]	25.22	28.25
Weight for 100 mm useful stroke [kg]	1.3	1.3
Starting torque [Nm]	2.6	2.8
Moment of inertia of pulleys [g · mm ²]	4.035.390	4.035.390

*1) It is possible to obtain stroke up to 10.880 (SP3), 10.750 (SP4) by means of special Rollon joints.

*2) Positioning repeatability is dependent on the type of transmission used.

Tab. 24

E-SMART 100 Load capacity

Type	F _x [N]		F _y [N]		F _z [N]		M _x [Nm]		M _y [Nm]		M _z [Nm]	
	Stat.	Dyn.	Stat.	Dyn.	Stat.	Dyn.	Stat.	Dyn.	Stat.	Dyn.	Stat.	Dyn.
E-SMART 100 SP3	4440	3060	130860	93577	130860	93577	1500	1073	12039	8609	12039	8609
E-SMART 100 SP4	4440	3060	174480	124770	174480	124770	2000	1430	19416	13884	19416	13884

See verification under static load and lifetime on page SL-2 and SL-3

Tab. 27

Moments of inertia of the aluminum body

Type	I _x [10 ⁷ mm ⁴]	I _y [10 ⁷ mm ⁴]	I _p [10 ⁷ mm ⁴]
E-SMART 100 SP	0.247	0.316	0.536

Tab. 25

Driving belt

The driving belt is manufactured from a friction resistant polyurethane and with steel cords for high tensile stress resistance.

Type	Type of belt	Belt width [mm]	Weight [kg/m]
E-SMART 100 SP	50 AT 10	50	0.290

Tab. 26

Belt length (mm) = 2 x L - 395 (SP3)
2 x L - 252 (SP4)

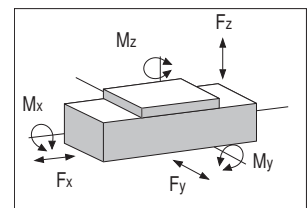

> Lubrication

SP linear units with ball bearing guides

The ball bearing carriages of the SP versions are fitted with a retention cage that eliminates "steel-steel" contact between adjacent revolving parts and prevents misalignment of these in the circuits.

This system guarantees a long interval between maintenances: SP version: every 5000 km or 1 year of use, based on the value reached first. If

a longer service life is required or in case of high dynamic or high loaded applications please contact our offices for further verification.

E-SMART

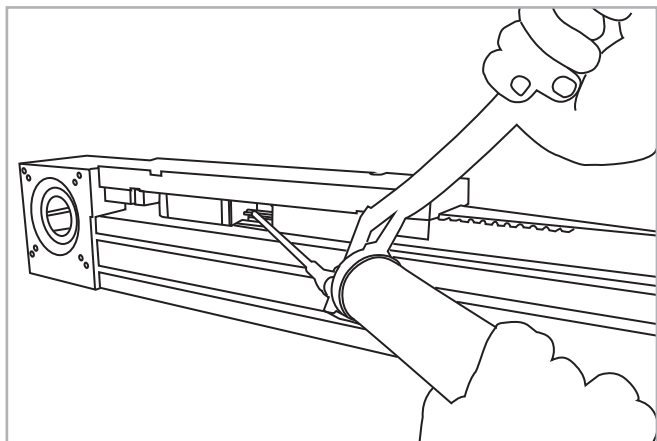

Fig. 9

- Insert the tip of the grease gun into the specific grease blocks.
- Type of lubricant: Lithium soap grease of class NLGI 2.
- For specially stressed applications or hostile environmental conditions, lubrication should be applied out more frequently.
Contact Rollon for further advice

Quantity of lubricant necessary for re-lubrication for each block:

Type	Unit [g]
E-SMART 30	1
E-SMART 50	1
E-SMART 80	2-3
E-SMART 100	5-6

Tab. 28

> Simple shafts

AS type simple shafts

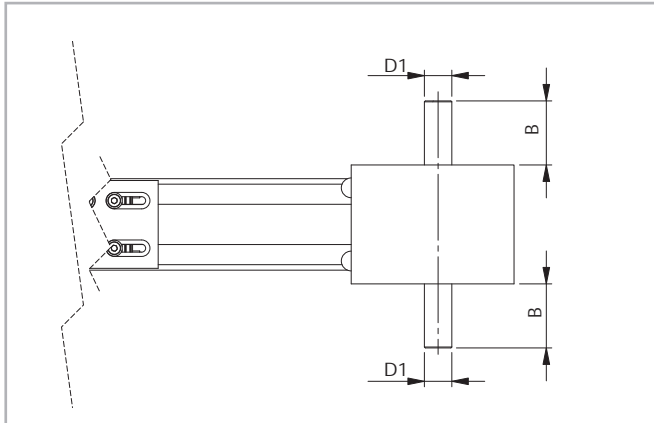

Position of the simple shaft can be to the right or to the left of the drive head.

Fig. 10

This head configuration is obtained by utilizing an assembly kit delivered as a separate accessory item.

Shaft can be installed on the left or right side of the drive head as decided by the customer.

Units (mm)

Applicable to unit	Shaft type	B	D1	AS assembly kit code
E-SMART 30	AS 12	25	12h7	G000348
E-SMART 50	AS 15	35	15h7	G000851
E-SMART 80	AS 20	36.5	20h7	G000828
E-SMART 100	AS 25	50	25h7	G000649

Tab. 29

> Hollow shaft

Hollow shaft type FP - Standard supply

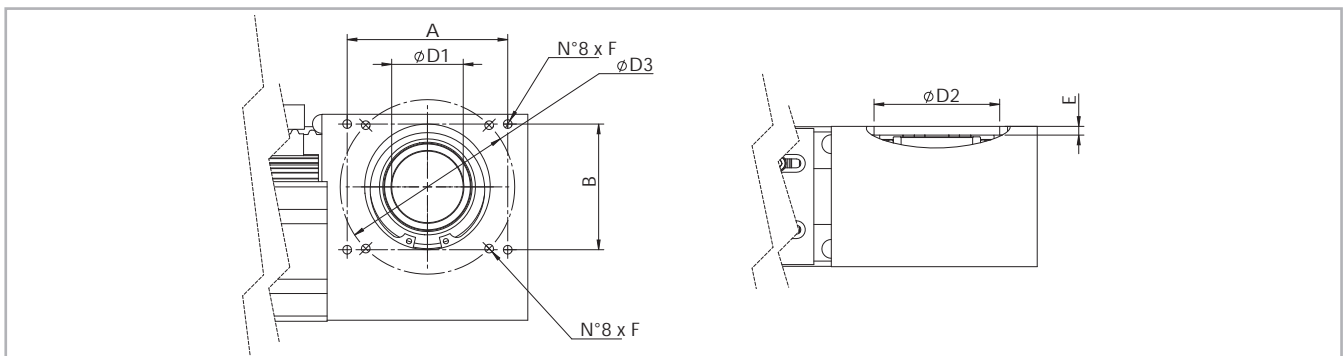

Fig. 11

Units (mm)

Applicable to unit	Shaft type	D1	D2	D3	E	F	A x B	Drive head code
E-SMART 30	FP 22	22H7	42J6	68	3	M5	-	2T
E-SMART 50	FP 34	34H7	72J6	90	3.5	M6	-	2T
E-SMART 80	FP 41	41H7	72J6	100	5	M6	92x72	2Z
E-SMART 100	FP 50	50H7	95J6	130	3.5	M8	109x109	2Y

Tab. 30

An (optional) connection flange is required to fit the standard reduction units selected by Rollon.

For further information contact our offices.

> Linear units in parallel

Synchronization kit for use of SMART linear units in parallel

When movement consisting of two linear units in parallel is essential, a synchronization kit must be used. This consists of original Rollon lamina type precision joints complete with tapered splines and hollow aluminum drive shafts.

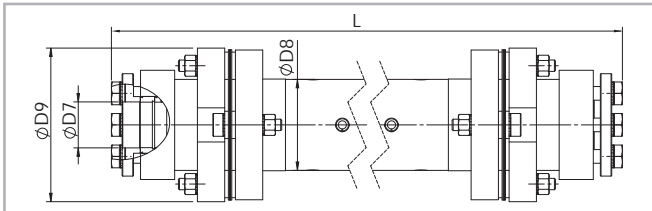

Fig. 12

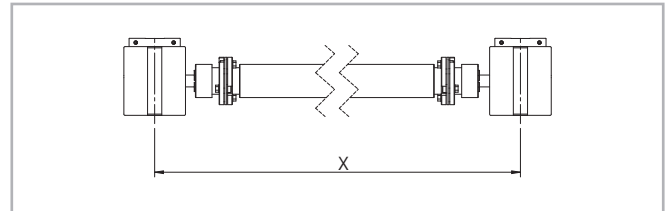

Fig. 13

Dimensions (mm)

Applicable to unit	Shaft type	D7	D8	D9	Code	Formula for length calculation
E-SMART 30	AP 12	12	25	45	GK12P...1A	$L = X - 51$ [mm]
E-SMART 50	AP 15	15	40	69.5	GK15P...1A	$L = X - 79$ [mm]
E-SMART 80	AP 20	20	40	69.5	GK20P...1A	$L = X - 97$ [mm]
E-SMART 100	AP 25	25	70	99	GK25P...1A	$L = X - 145$ [mm]

Tab. 31

> Accessories

Fixing by brackets

The ball bearing guide linear drive system of Rollon SMART System series linear units enables them to support loads in any direction.

They can therefore be installed in any position.

To install the SMART System series units, we recommend use of one of the systems indicated below:

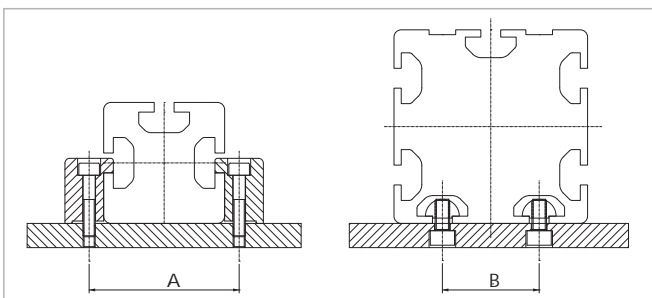

Fig. 14

Dimensions (mm)

	A	B
E-SMART 30	42	-
E-SMART 50	62	-
E-SMART 80	92	40
E-SMART 100	120	50

Tab. 32

Fixing brackets

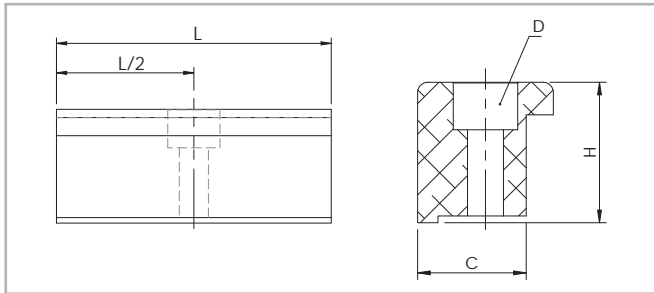
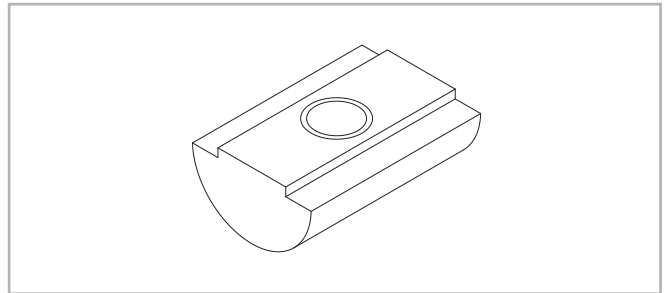

Fig. 15

T-nuts



Steel nuts to be used in the slots of the body.

Fig. 16

Dimensions (mm)

	C	H	L	D	Cod. Rollon
E-SMART 30	16	17.5	50	M5	1001490
E-SMART 50	16	26.9	50	M5	1000097
E-SMART 80	16	20.7	50	M5	1000111
E-SMART 100	31	28.5	100	M10	1002377

Tab. 33

Units (mm)

	Hole	Length	Cod. Rollon
E-SMART 30	M5	20	6000436
E-SMART 50	M6	20	6000437
E-SMART 80	M6	20	6000437
E-SMART 100	M6	20	6000437

Tab. 34

Proximity

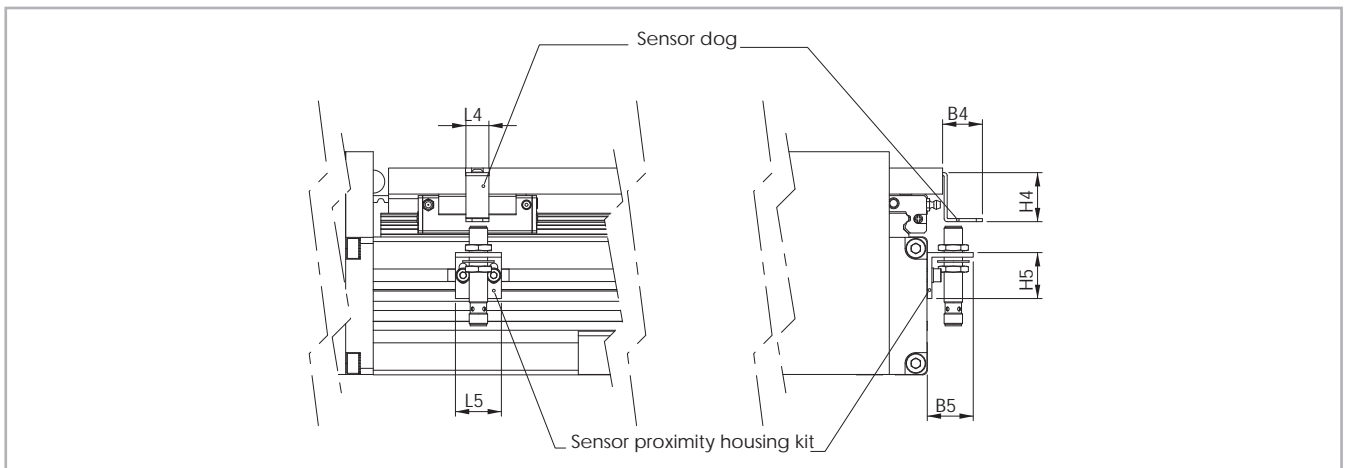

Fig. 17

Sensor proximity housing kit

Aluminum block equipped with T-nuts for fixing

Sensor dog

Iron plate mounted on the carriage used for the proximity operation

Units (mm)

	B4	B5	L4	L5	H4	H5	For proximity	Sensor dog code	Sensor proximity kit code
E-SMART 30	30	30	30	30	15	30	∅ 8	G000847	G000901
E-SMART 50	26	30	15	30	32	30	∅ 8	G000833	G000838
E-SMART 80	26	30	15	30	32	30	∅ 8	G000833	G000838
E-SMART 100	26	30	15	30	32	30	∅ 8	G000833	G000838

Tab. 35

Adapter flange for gearbox assembly

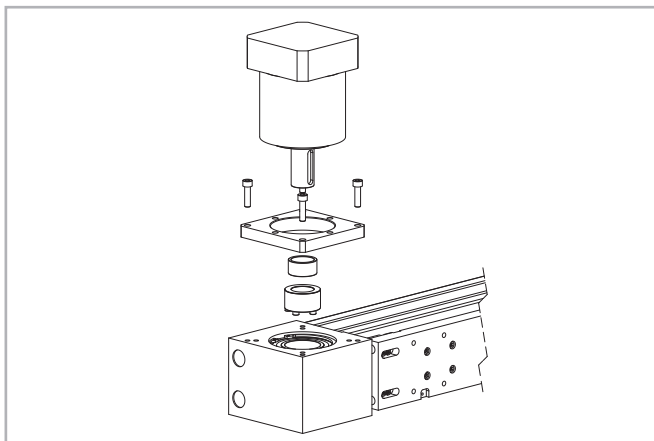

Fig. 18

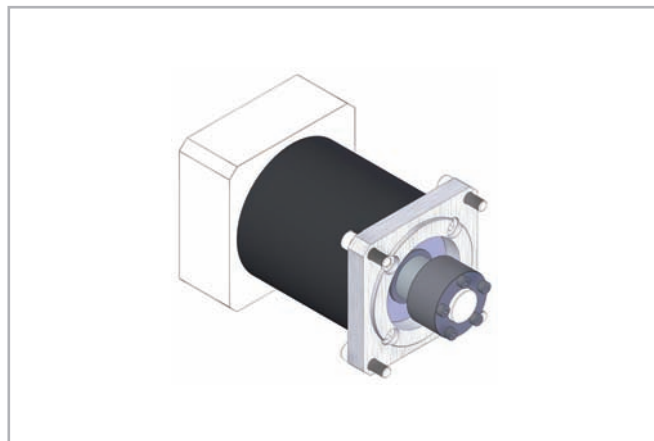

Fig. 19

Assembly kit includes: shrink disk; adapter plate; fixing hardware

Unit type	Gearbox type (not included)	Kit Code
E-SMART 30	MP053	G000356
	LC050; LP050; PE2	G000357
	SW030	G000383
E-SMART 50	MP060; PLE60	G000852
	LC070; MPV00; LP070; PE3	G000853
	SW040	G000854
E-SMART 80	P3	G000824
	MP080	G000826
	LC090; MPV01; LP090; PE4	G000827
	MP105	G000830
	PE3; LP070	G001078
	SPO75; PLN090	G000859
	SP060; PLN070	G000829
	SW040	G000866
	SW050	G000895
E-SMART 100	MP130	G000482
	LC120; MPV02; LP120; PE5	G000483
	LC090	G000525
	MP105	G000527
	SW050	G000717

Tab. 36

For other gearbox type ask Rollon

Ordering key 

> **Identification codes for the E-SMART linear unit**

L	10	2Y	02000	2A	
	03 = 30				
	05 = 50				
	08 = 80				Type (30) 2S=SP2
	10 = 100				Type (50-80) 1T=SP1 - 2T=SP2 - 3T=SP3 - 4T=SP4 Type (100) 1A=SP1 - 2A=SP2 - 3A=SP3 - 4A=SP4
					L=total length of the unit
					Drive head code <i>see pg. SS-12</i>
					Linear unit type <i>see from pg. SS-5 to pg. SS-10</i>
					Linear unit series E-SMART <i>see pg. SS-2</i>

In order to create identification codes for Actuator Line, you can visit: <http://configureactuator.rollon.com>

R-SMART series



> R-SMART series description

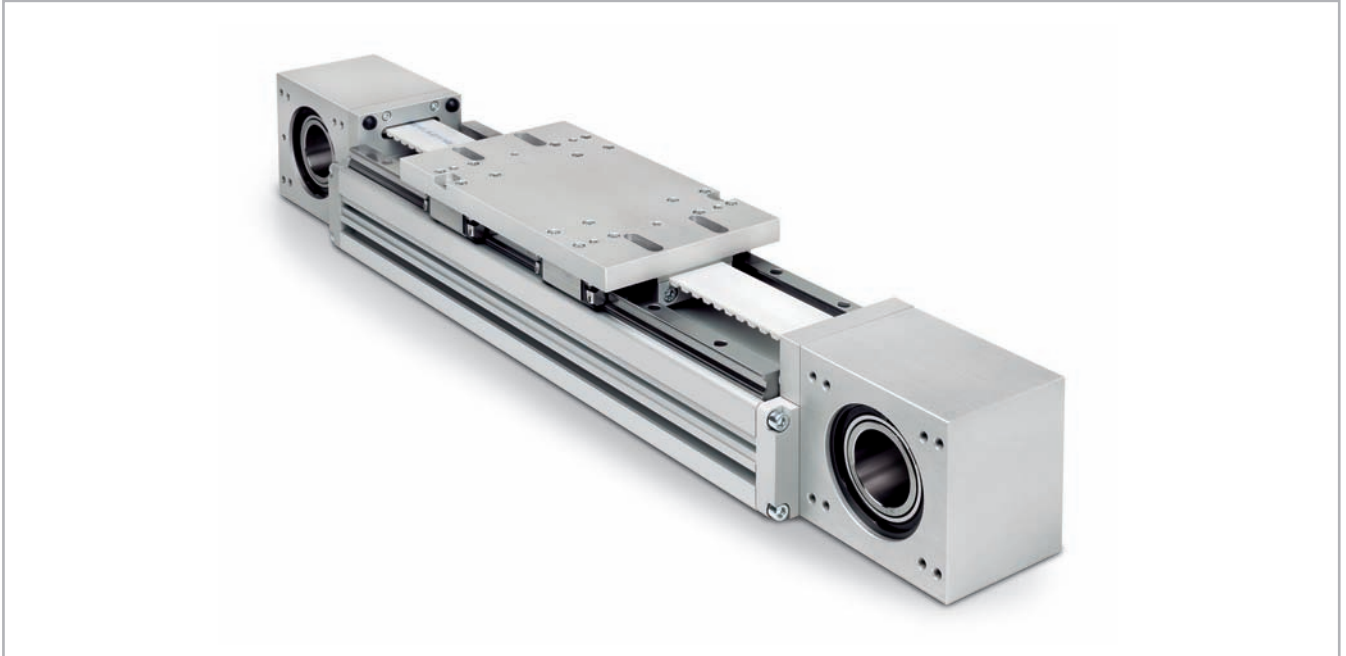

Fig. 20

R-SMART

The R-SMART series linear units are particularly suitable for: heavy loads, pulling and pushing very heavy weights, demanding work cycles, possible cantilever or gantry mounting, and operation in industrial automated lines.

The extruded and anodized aluminum self-supporting structure with a rectangular section is available in three sizes ranging from 120 to 220 mm. Transmission is achieved with a polyurethane steel reinforced driving belt. Also featured is a dual rail system with four or more recirculating ball bearing runner blocks. Multiple sliders are available to further improve load capacity.

These units are best used in applications requiring very heavy loads in extremely confined spaces, and where machines cannot be stopped to carry out ordinary system maintenance.

> The components

Extruded bodies

The anodized aluminum extrusions used for the bodies of the Rollon SMART series linear units were designed and manufactured in cooperation with a leading company in this field to obtain the right combination of high mechanical strength and reduced weight. The anodized aluminum alloy 6060 used (see physical chemical characteristics below for further information) was extruded with dimensional tolerances complying with EN 755-9 standards.

Driving belt

The Rollon SMART series linear units use steel reinforced polyurethane drive belts with AT pitch. This belt is ideal due to its high load transmis-

sion characteristics, compact size, and low noise. Used in conjunction with a backlash-free pulley, smooth alternating motion can be achieved. Optimization of the maximum belt width/body dimension ratio enables the following performance characteristics to be achieved:

- **High speed**
- **Low noise**
- **Low wear**

Carriage

The carriage of the Rollon SMART series linear units is made entirely of machined anodized aluminum. The dimensions vary depending on the type. Rollon offers multiple carriages to accommodate a vast array of applications.

General data about aluminum used: AL 6060

Chemical composition [%]

Al	Mg	Si	Fe	Mn	Zn	Cu	Impurities
Remainder	0.35-0.60	0.30-0.60	0.30	0.10	0.10	0.10	0.05-0.15

Tab. 37

Physical characteristics

Density	Coeff. of elasticity	Coeff. of thermal expansion (20°-100°C)	Thermal conductivity (20°C)	Specific heat (0°-100°C)	Resistivity	Melting point
$\frac{\text{kg}}{\text{dm}^3}$	$\frac{\text{kN}}{\text{mm}^2}$	$\frac{10^{-6}}{\text{K}}$	$\frac{\text{W}}{\text{m} \cdot \text{K}}$	$\frac{\text{J}}{\text{kg} \cdot \text{K}}$	$\Omega \cdot \text{m} \cdot 10^{-9}$	°C
2.7	70	23.8	200	880-900	33	600-655

Tab. 38

Mechanical characteristics

Rm	Rp (02)	A	HB
$\frac{\text{N}}{\text{mm}^2}$	$\frac{\text{N}}{\text{mm}^2}$	%	—
250	200	10	75

Tab. 39

> The linear motion system

The linear motion system has been designed to meet the load capacity, speed, and maximum acceleration conditions of a wide variety of applications. Rollon SMART series systems feature a linear motion system with ball bearing guides:

Performance characteristics:

- The ball bearing guides with high load capacity are mounted in a dedicated seat on the aluminum body.
- The carriage of the linear unit is assembled on preloaded ball bearing blocks that enables the carriage to withstand loading in the four main directions.
- The ball bearing carriages of the SP versions are also fitted with a retention cage that eliminates "steel-steel" contact between adjacent revolving parts and prevents misalignment.
- The blocks have seals on both sides and, when necessary, an additional scraper can be fitted for very dusty conditions.

The linear motion system described above offers:

- High speed and acceleration
- High load capacity
- High permissible bending moments
- Low friction
- Long life
- Low noise

R-SMART section

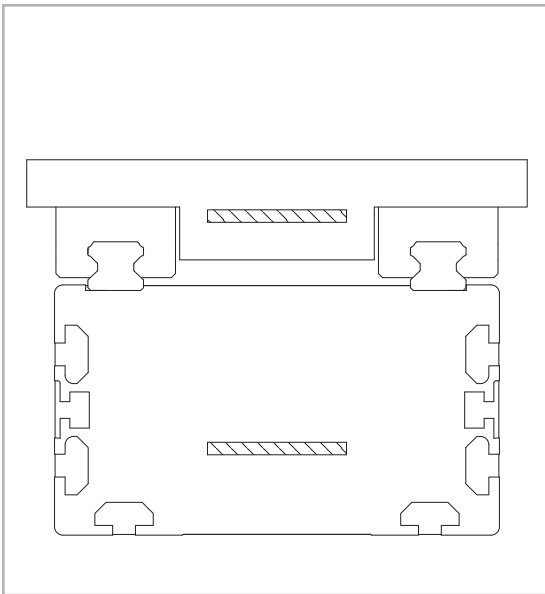
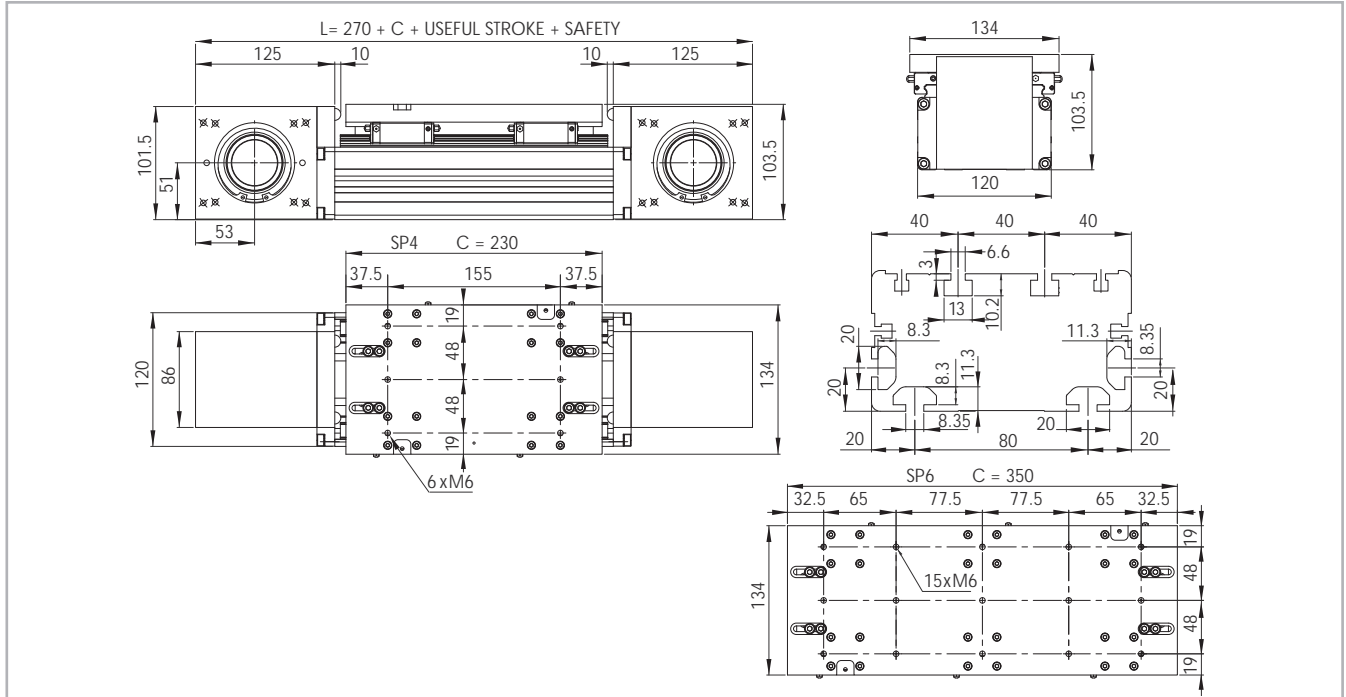

Fig. 21

> R-SMART 120 SP4 - SP6

R-SMART 120 Dimensions



* The length of the safety stroke is provided on request according to the customer's specific requirements.

Fig. 22

Technical data

	Type	
	R-SMART 120 SP4	R-SMART 120 SP6
Max. useful stroke length [mm]*1	6050	5930
Max. positioning repeatability [mm]*2	± 0.05	± 0.05
Max. speed [m/s]	4.0	4.0
Max. acceleration [m/s ²]	50	50
Type of belt	40 AT 10	40 AT 10
Type of pulley	Z 21	Z 21
Pulley pitch diameter [mm]	66.84	66.84
Carriage displacement per pulley turn [mm]	210	210
Carriage weight [kg]	3	4
Zero travel weight [kg]	12.9	15
Weight for 100 mm useful stroke [kg]	0.9	0.9
Starting torque [Nm]	1.95	2.3
Moment of inertia of pulleys [g · mm ²]	1.054.300	1.054.300

*1) It is possible to obtain stroke up to 11.200 (SP4), 11.080 (SP6) by means of special Rollon joints.

*2) Positioning repeatability is dependent on the type of transmission used.

Tab. 40

R-SMART 120 - Load capacity

Type	F _x [N]		F _y [N]		F _z [N]		M _x [Nm]		M _y [Nm]		M _z [Nm]	
	Stat.	Dyn.	Stat.	Dyn.	Stat.	Dyn.	Stat.	Dyn.	Stat.	Dyn.	Stat.	Dyn.
R-SMART 120 SP4	2812	1824	48400	29120	48400	29120	2226	1340	3122	1878	3122	1878
R-SMART 120 SP6	2812	1824	72600	43680	72600	43680	3340	2009	5953	3582	5953	3582

See verification under static load and lifetime on page SL-2 and SL-3

Tab. 43

Moments of inertia of the aluminum body

Type	I _x [10 ⁷ mm ⁴]	I _y [10 ⁷ mm ⁴]	I _p [10 ⁷ mm ⁴]
R-SMART 120 SP	0.108	0.367	0.475

Tab. 41

Driving belt

The driving belt is manufactured from a friction resistant polyurethane and with steel cords for high tensile stress resistance.

Type	Type of belt	Belt width [mm]	Weight [kg/m]
R-SMART 120 SP	40 AT 10	40	0.23

Tab. 42

Belt length (mm) = 2 x L - 115 (SP4)
2 x L - 235 (SP6)

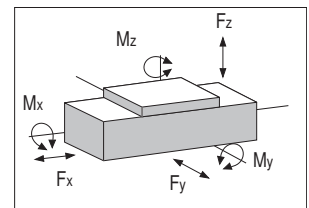

> R-SMART 160 SP4 - SP6

R-SMART 160 Dimensions

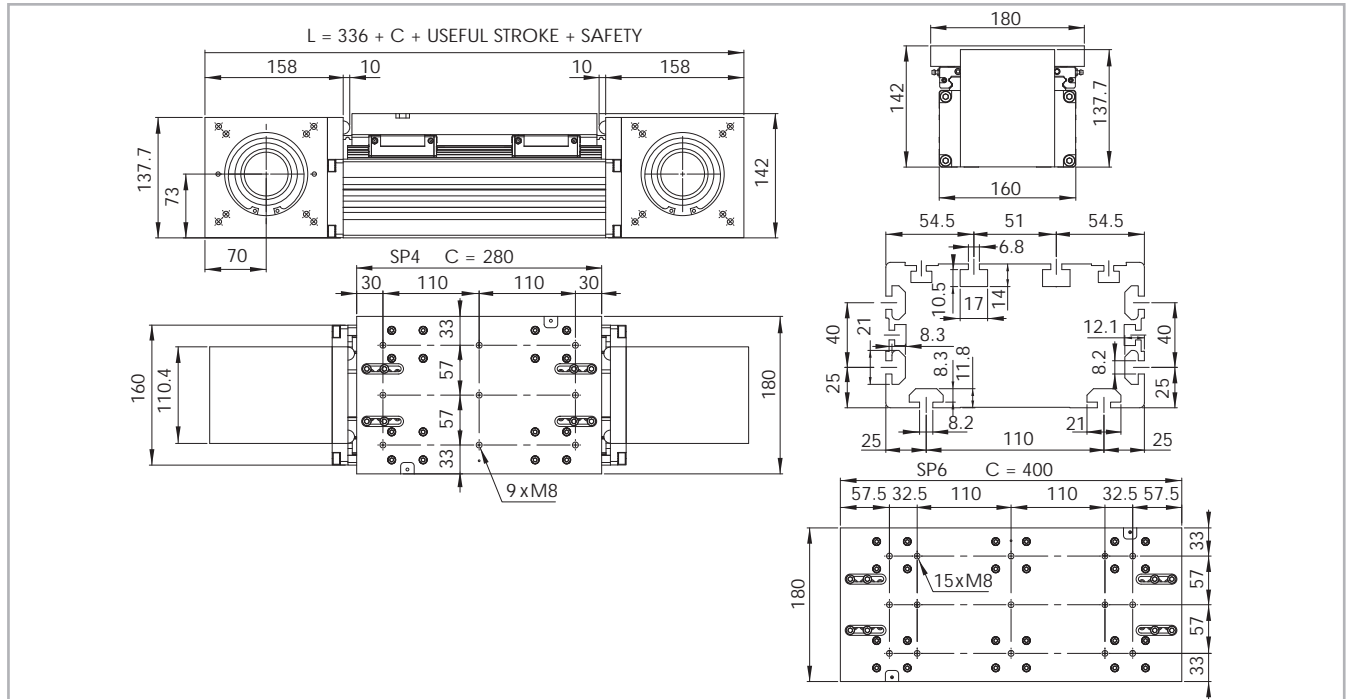

* The length of the safety stroke is provided on request according to the customer's specific requirements.

Fig. 23

Technical data

	Type	
	R-SMART 160 SP4	R-SMART 160 SP6
Max. useful stroke length [mm]*1	6000	5880
Max. positioning repeatability [mm]*2	± 0.05	± 0.05
Max. speed [m/s]	4.0	4.0
Max. acceleration [m/s ²]	50	50
Type of belt	50 AT 10	50 AT 10
Type of pulley	Z 27	Z 27
Pulley pitch diameter [mm]	85.94	85.94
Carriage displacement per pulley turn [mm]	270	270
Carriage weight [kg]	5.4	7.5
Zero travel weight [kg]	24.4	27.9
Weight for 100 mm useful stroke [kg]	1.75	1.75
Starting torque [Nm]	3.4	3.95
Moment of inertia of pulleys [g · mm ²]	4.035.390	4.035.390

*1) It is possible to obtain stroke up to 11.200 (SP4), 11.080 (SP6) by means of special Rollon joints

*2) The positioning repeatability depends upon the type of transmission used

Tab. 44

R-SMART 160 SP4 - R-SMART 160 SP6 - Load capacity

Type	F _x [N]		F _y [N]		F _z [N]		M _x [Nm]		M _y [Nm]		M _z [Nm]	
	Stat.	Dyn.	Stat.	Dyn.	Stat.	Dyn.	Stat.	Dyn.	Stat.	Dyn.	Stat.	Dyn.
R-SMART 160 SP4	4440	3060	86800	69600	86800	69600	5034	4037	7118	5707	7118	5707
R-SMART 160 SP6	4440	3060	130200	104400	130200	104400	7552	6055	12109	9709	12109	9709

See verification under static load and lifetime on page SL-2 and SL-3

Tab. 47

Moments of inertia of the aluminum body

Type	I _x [10 ⁷ mm ⁴]	I _y [10 ⁷ mm ⁴]	I _p [10 ⁷ mm ⁴]
R-SMART 160 SP	0.383	1.313	1.696

Tab. 45

Driving belt

The driving belt is manufactured from a friction resistant polyurethane and with steel cords for high tensile stress resistance.

Type	Type of belt	Belt width [mm]	Weight [kg/m]
R-SMART 160 SP	50 AT 10	50	0.29

Tab. 46

Belt length (mm) = 2 x L - 150 (SP4)
 2 x L - 270 (SP6)

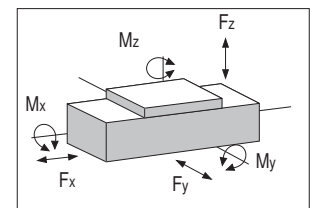

R-SMART 220 SP4- SP6

R-SMART 220 Dimensions

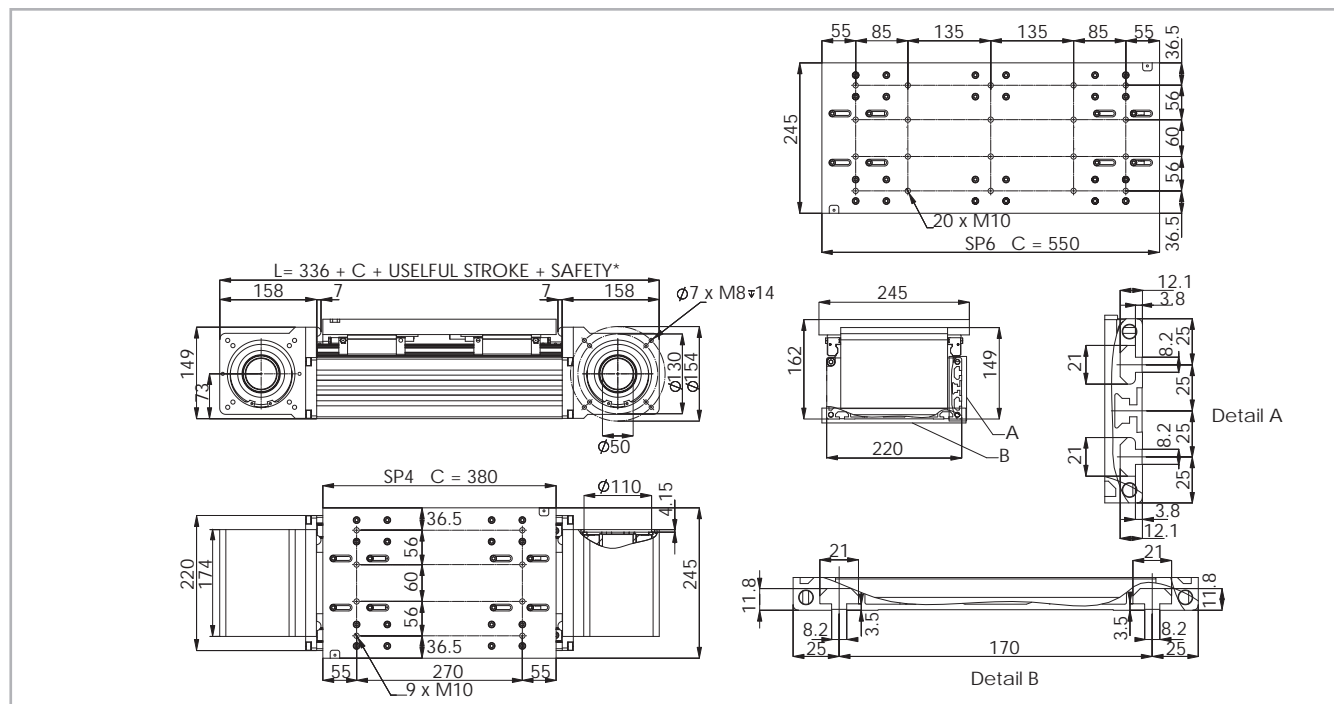

* The length of the safety stroke is provided on request according to the customer's specific requirements.

Fig. 24

Technical data

	Type	
	R-SMART 220 SP4	R-SMART 220 SP6
Max. useful stroke length [mm]*1	5900	5730
Max. positioning repeatability [mm]*2	± 0.05	± 0.05
Max. speed [m/s]	4.0	4.0
Max. acceleration [m/s ²]	50	50
Type of belt	100 AT 10	100 AT 10
Type of pulley	Z 32	Z 32
Pulley pitch diameter [mm]	101.86	101.86
Carriage displacement per pulley turn [mm]	320	320
Carriage weight [kg]	12.1	16.95
Zero travel weight [kg]	41.13	49.93
Weight for 100 mm useful stroke [kg]	2.45	2.45
Starting torque [Nm]	4.3	7
Moment of inertia of pulleys [g · mm ²]	12.529.220	12.529.220

*1) It is possible to obtain stroke up to 11.100 (SP4), 10.930 (SP6) by means of special Rollon joints.

*2) Positioning repeatability is dependent on the type of transmission used.

Tab. 48

R-SMART 220 SP4 - R-SMART 220 SP6 - Load capacity

Type	F _x [N]		F _y [N]		F _z [N]		M _x [Nm]		M _y [Nm]		M _z [Nm]	
	Stat.	Dyn.	Stat.	Dyn.	Stat.	Dyn.	Stat.	Dyn.	Stat.	Dyn.	Stat.	Dyn.
R-SMART 220 SP4	8880	6360	158000	110000	158000	110000	13430	9350	17380	12100	17380	12100
R-SMART 220 SP6	8880	6360	237000	165000	237000	165000	20145	14025	30810	21450	30810	21450

See verification under static load and lifetime on page SL-2 and SL-3

Tab. 51

Moments of inertia of the aluminum body

Type	I _x [10 ⁷ mm ⁴]	I _y [10 ⁷ mm ⁴]	I _p [10 ⁷ mm ⁴]
R-SMART 220 SP	0.663	3.658	4.321

Tab. 49

Driving belt

The driving belt is manufactured from a friction resistant polyurethane and with steel cords for high tensile stress resistance.

Type	Type of belt	Belt width [mm]	Weight [kg/m]
R-SMART 220 SP	100 AT 10	100	0.58

Tab. 50

Belt length (mm) = 2 x L - 130 (SP4)
2 x L - 300 (SP6)

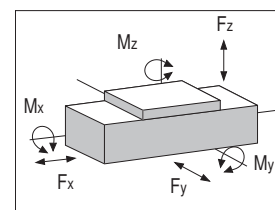

> Lubrication

SP linear units with ball bearing guides

SP Linear units are equipped with self lubricating linear ball guides. The ball bearing carriages of the SP versions are also fitted with a retention cage that eliminates "steel-steel" contact between adjacent revolving parts and prevents misalignment.

Special lubrication reservoirs are mounted on the front plates of the linear blocks which continuously provide the necessary amount of grease to the

ball raceways under load. These lubrication reservoirs also considerably reduce the frequency of lubrication of the module. This system guarantees a long interval between maintenances: SP version: every 5000 km or 1 year of use, based on the value reached first. If a longer service life is required or in case of high dynamic or high loaded applications please contact our offices for further verification.

R-SMART

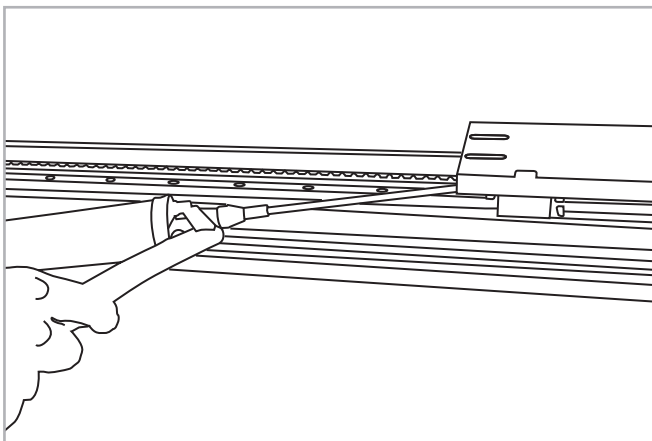

Fig. 25

- Insert the tip of the grease gun into the specific grease blocks.
- Type of lubricant: Lithium soap grease of class NLGI 2.
- For specially stressed applications or hostile environmental conditions, lubrication should be applied out more frequently.
Contact Rollon for further advice

Quantity of lubricant necessary for re-lubrication for each block:

Type	Quantity of Grease (g)
R-SMART 120	1
R-SMART 160	2-3
R-SMART 220	5-6

Tab. 52

> Simple shafts

AS type simple shafts

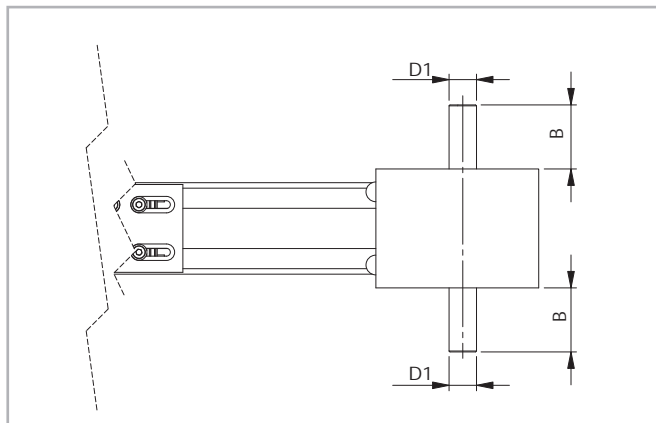

Position of the simple shaft can be to the right or to the left of the drive head.

Fig. 26

This head configuration is obtained by utilizing an assembly kit delivered as a separate accessory item.

Shaft can be installed on the left or right side of the drive head as decided by the customer.

Units (mm)

Applicable to unit	Shaft type	B	D1	AS assembly kit code
R-SMART 120	AS 20	36	20h7	G000828
R-SMART 160	AS 25	50	25h7	G000649
R-SMART 220	AS 25	50	25h7	G000649

Tab. 53

> Hollow shaft

Hollow shaft type FP - Standard supply

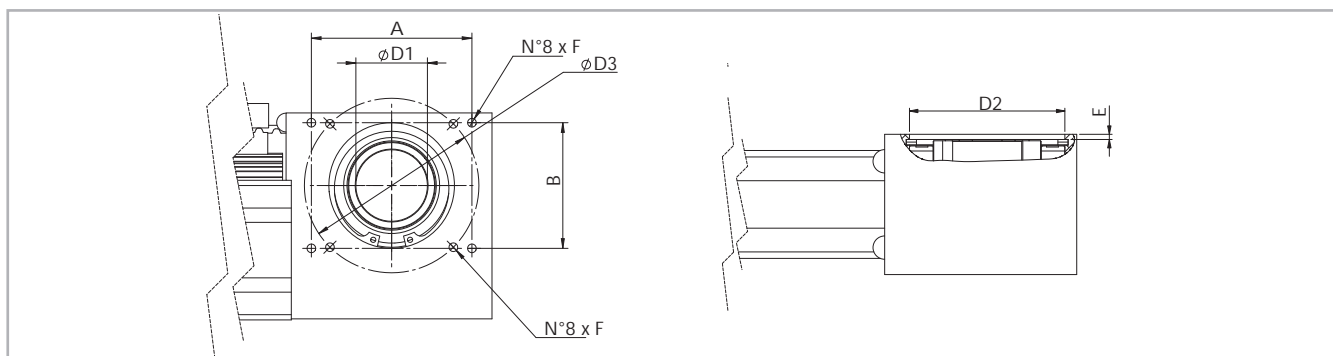

Fig. 27

Units (mm)

Applicable to unit	Shaft type	D1	D2	D3	E	F	A x B	Drive head code
R-SMART 120	FP 41	41H7	72J6	100	3.5	M6	92x72	2Y
R-SMART 160	FP 50	50H7	95J6	130	3.5	M8	109x109	2Y
R-SMART 220	FP 50	50H7	110J6	130	4	M8	109x109	2Y

Tab. 54

An (optional) connection flange is required to fit the standard reduction units selected by Rollon.

For further information contact our offices.

> Accessories

Fixing by brackets

The ball bearing guide linear drive system of Rollon SMART System series linear units enables them to support loads in any direction. They can therefore be installed in any position.

To install the SMART System series units, we recommend use of one of the systems indicated below:

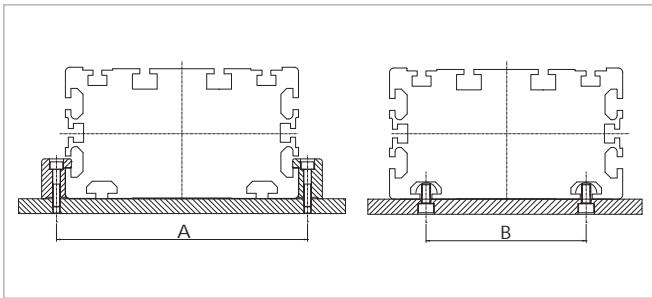

Fig. 28

Units (mm)

	A	B
R-SMART 120	132	80
R-SMART 160	180	110
R-SMART 220	240	170

Tab. 55

Fixing brackets

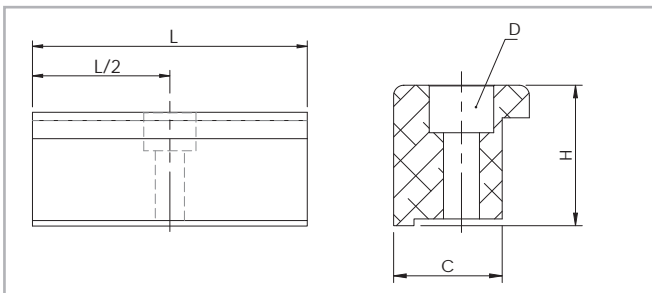

Fig. 29

Dimensions (mm)

	C	H	L	D	Code Rollon
R-SMART 120	16	20.7	50	M5	1000111
R-SMART 160	31	28.5	100	M10	1002377
R-SMART 220	31	28.5	100	M10	1002377

Tab. 56

T-nuts

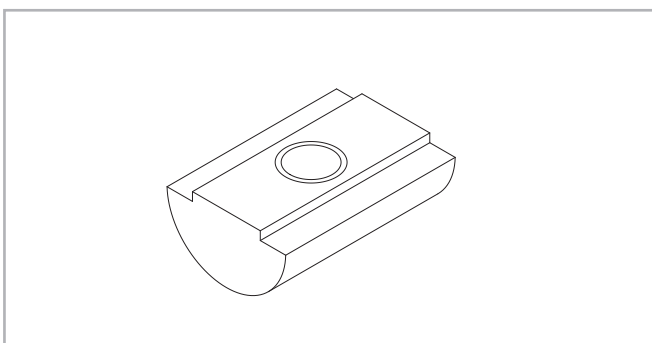

Steel nuts to be used in the slots of the body.

Fig. 30

Units (mm)

	Hole	Length	Code Rollon
R-SMART 120	M6	20	6000437
R-SMART 160	M6	20	6000437
R-SMART 160	M8	20	6001544
R-SMART 220	M6	20	6000437
R-SMART 220	M8	20	6001544

Tab. 57

Proximity

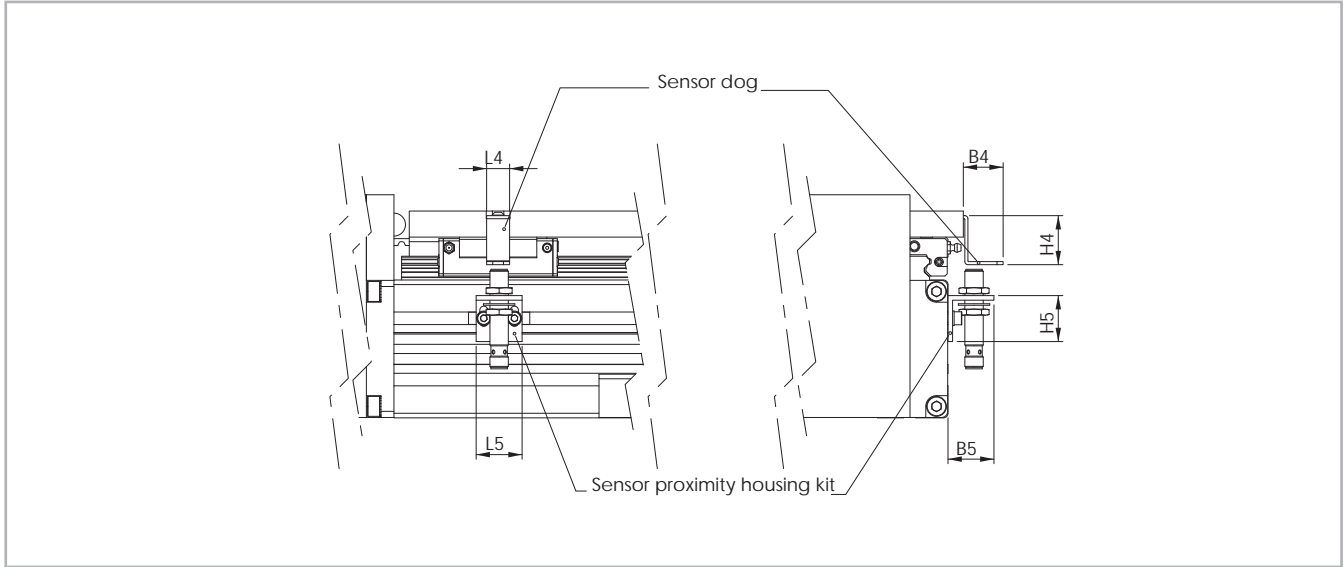

Fig. 31

Sensor proximity housing kit

Aluminum block equipped with T-nuts for fixing

Sensor dog

Iron plate mounted on the carriage used for the proximity operation

Units (mm)

	B4	B5	L4	L5	H4	H5	For proximity	Sensor dog	Sensor proximity housing kit
R-SMART 120	26	30	15	30	32	30	Ø 8/12	G000833	G000844
R-SMART 160	26	30	15	30	32	30	Ø 8/12	G000833	G000838
R-SMART 220	26	30	15	30	32	30	Ø 8/12	G000833	G000838

Tab. 58

Assembly kits

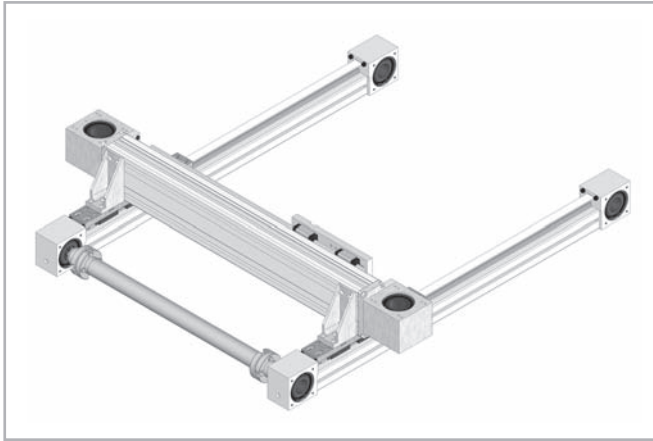







Fig. 32



Fig. 33

For the direct assembly of R-SMART linear units on other types of actuators Rollon offers dedicated assembly kits. The table below shows the allowed combinations as well as the assembly kit codes.

Kit	Code	X No rail at each end (mm)
 R-SMART 120 on E-SMART 50	G000899	60
 R-SMART 120 on E-SMART 80	G000863	90
 R-SMART 160 on E-SMART 80	G000902	90
 R-SMART 160 on E-SMART 100	G000903	110
 R-SMART 220 on E-SMART 100	G001207	110

Tab. 59

Adapter flange for gearbox assembly

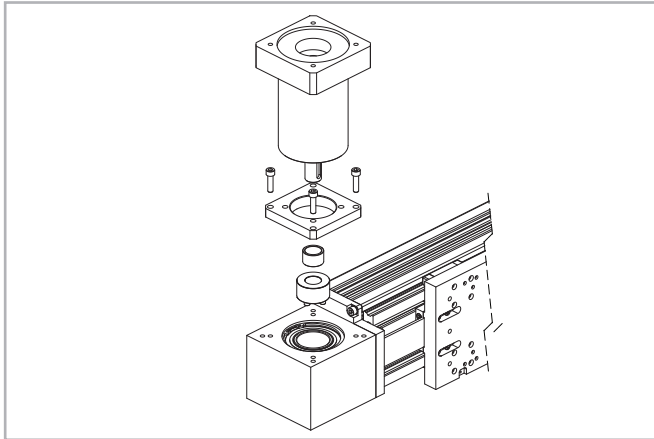

Fig. 34

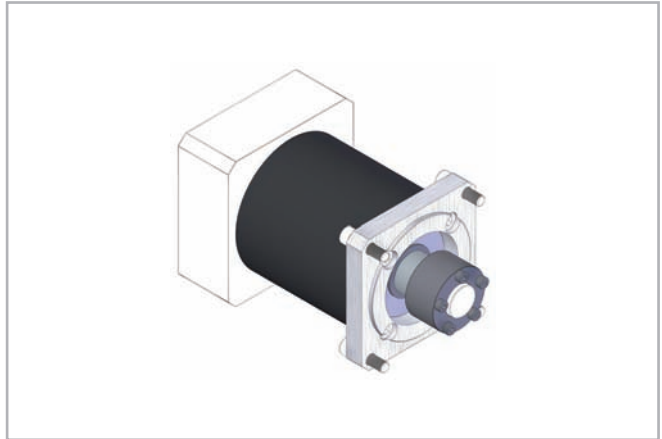

Fig. 35

Assembly kit includes: shrink disk; adapter plate; fixing hardware

Unit type	Gearbox type (not included)	Kit Code
R-SMART 120	P3	G000824
	MP080	G000826
	LC90; MPV01; LP090; PE4	G000827
	MP105	G000830
	PE3; LP070	G001078
	SP060; PLN070	G000829
	SP070; PLN090	G000859
	SW040	G000866
R-SMART 160	MP130	G000482
	LC120; MPV02; LP120; PE5	G000483
	LC090; LP090	G000525
	MP105	G000527
	SP075; PLN090	G000526
	SW050	G000717
R-SMART 220	MP130	G001045
	MP105	G001047
	LC120; MPV02; LP120; PE5	G001049

Tab. 60

For other gearbox type ask Rollon S.p.A.

Ordering key



> Identification codes for the R-SMART linear unit

D	12 12=120 16=160 22=220	2Y	02000	4A	
					Type (120-160-220) 4A=SP4 6A=SP6
					L=total length of the unit
					Drive head code <i>see pg. SS-24</i>
					Linear unit type <i>see from pg. SS-20 to pg. SS-22</i>
					Linear unit series R-SMART <i>see pg. SS-17</i>

In order to create identification codes for Actuator Line, you can visit: <http://configureactuator.rollon.com>

S-SMART series



> S-SMART series description



Fig. 36

S-SMART

The S-SMART series linear units were designed to meet the vertical motion requirements in gantry applications or for applications where the aluminum profile must be moving and the carriage must be fixed.

The self-supporting extruded and anodized aluminum structure is available in three sizes. Since it is a rigid system, it is ideal for a "Z" axis in a 3-axis system by using a linear guide rail.

In addition, the S-SMART series has been specifically designed and configured to be easily assembled with the R-SMART series by using a simple bracket.

> The components

Extruded profile

The anodized aluminum extrusions used for the bodies of the Rollon SMART series linear units were designed and manufactured in cooperation with a leading company in this field to obtain the right combination of high mechanical strength and reduced weight. The anodized aluminum alloy 6060 used (see physical chemical characteristics below for further information) was extruded with dimensional tolerances complying with EN 755-9 standards.

characteristics, compact size and low noise. Used in conjunction with a backlash-free pulley, smooth alternating motion can be achieved. Optimization of the maximum belt width/body dimension ratio enables the following performance characteristics to be achieved:

- **High speed**
- **Low noise**
- **Low wear**

Driving belt

The Rollon SMART series linear units use steel reinforced polyurethane drive belts with AT pitch. This belt is ideal due to its high load transmission

Carriage

The carriage of the Rollon SMART series linear units is made entirely of anodized aluminum. The dimensions vary depending on the type.

General data about aluminum used: AL 6060

Chemical composition [%]

Al	Mg	Si	Fe	Mn	Zn	Cu	Impurites
Remainder	0.35-0.60	0.30-0.60	0.30	0.10	0.10	0.10	0.05-0.15

Tab. 61

Physical characteristics

Density	Coeff. of elasticity	Coeff. of thermal expansion (20°-100°C)	Thermal conductivity (20°C)	Specific heat (0°-100°C)	Resistivity	Melting point
$\frac{\text{kg}}{\text{dm}^3}$	$\frac{\text{kN}}{\text{mm}^2}$	$\frac{10^{-6}}{\text{K}}$	$\frac{\text{W}}{\text{m} \cdot \text{K}}$	$\frac{\text{J}}{\text{kg} \cdot \text{K}}$	$\Omega \cdot \text{m} \cdot 10^{-9}$	°C
2.7	70	23.8	200	880-900	33	600-655

Tab. 62

Mechanical characteristics

Rm	Rp (02)	A	HB
$\frac{\text{N}}{\text{mm}^2}$	$\frac{\text{N}}{\text{mm}^2}$	%	—
250	200	10	75

Tab. 63

> The linear motion system

The linear motion system has been designed to meet the load capacity, speed, and maximum acceleration conditions of a wide variety of applications. Rollon SMART System series systems feature a linear motion system with ball bearing guides:

Performance characteristics:

- The ball bearing guides with high load capacity are mounted in a dedicated seat on the aluminum body.
- The carriage of the linear unit is assembled on pre-loaded ball bearing blocks that enables the carriage to withstand loading in the four main directions.
- The ball bearing carriages of the SP versions are also fitted with a retention cage that eliminates "steel-steel" contact between adjacent revolving parts and prevents misalignment.
- The blocks have seals on both sides and, when necessary, an additional scraper can be fitted for very dusty conditions.

The linear motion system described above offers:

- High speed and acceleration
- High load capacity
- High permissible bending moments
- Low friction
- Long life
- Low noise

S-SMART section

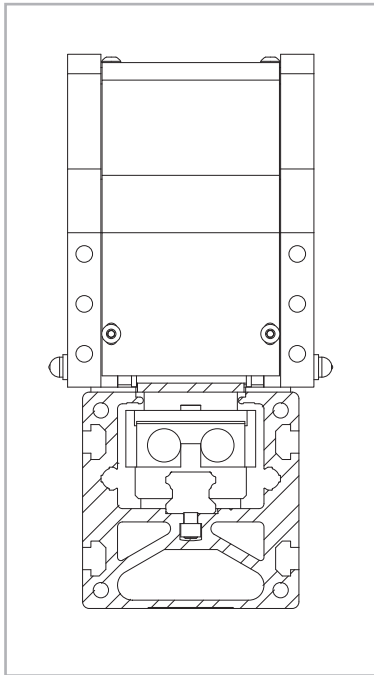
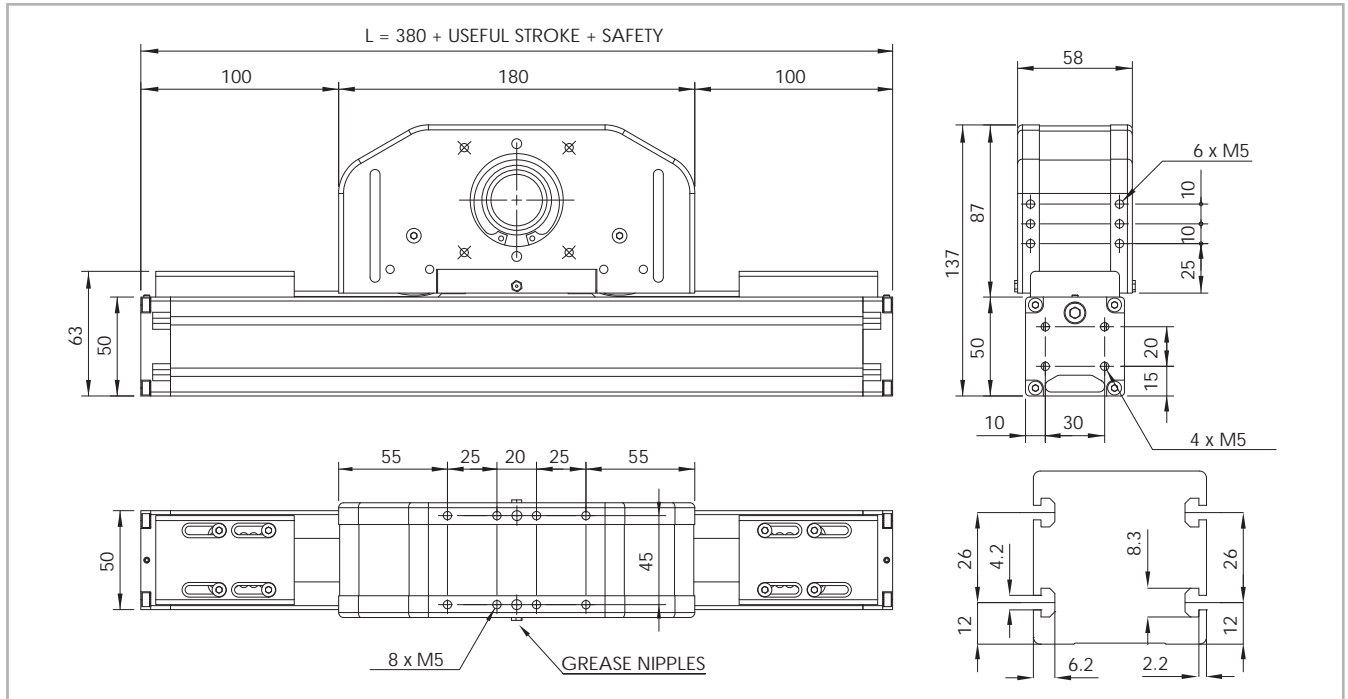

Fig. 37

> S-SMART 50 SP

S-SMART 50 SP Dimensions



* The length of the safety stroke is provided on request according to the customer's specific requirements.

Fig. 38

Technical data

	Type
	S-SMART 50 SP
Max. useful stroke length [mm]	1000
Max. positioning repeatability [mm]*1	± 0.05
Max. speed [m/s]	4.0
Max. acceleration [m/s ²]	50
Type of belt	22 AT 5
Type of pulley	Z 23
Pulley pitch diameter [mm]	36.61
Carriage displacement per pulley turn [mm]	115
Carriage weight [kg]	2
Zero travel weight [kg]	5.7
Weight for 100 mm useful stroke [kg]	0.4
Starting torque [Nm]	0.25

*1) Positioning repeatability is dependent on the type of transmission used

Tab. 64

Moments of inertia of the aluminum body

Type	I_x [10 ⁷ mm ⁴]	I_y [10 ⁷ mm ⁴]	I_p [10 ⁷ mm ⁴]
S-SMART 50 SP	0.025	0.031	0.056

Tab. 65

Driving belt

The driving belt is manufactured from a friction resistant polyurethane and with steel cords for high tensile stress resistance.

Type	Type of belt	Belt width [mm]	Weight [kg/m]
S-SMART 50 SP	22 AT 5	22	0.072

Tab. 66

Belt length (mm) = L + 30

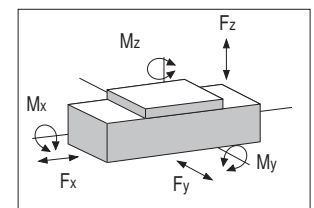

S-SMART 50 SP - Load capacity

Type	F_x [N]		F_y [N]		F_z [N]		M_x [Nm]		M_y [Nm]		M_z [Nm]	
	Stat.	Dyn.	Stat.	Dyn.	Stat.	Dyn.	Stat.	Dyn.	Stat.	Dyn.	Stat.	Dyn.
S-SMART 50 SP	809	508	6930	4616	6930	4616	43	29	229	152	229	152

See verification under static load and lifetime on page SL-2 and SL-3

Tab. 67

S-SMART 65 SP

S-SMART 65 SP Dimensions

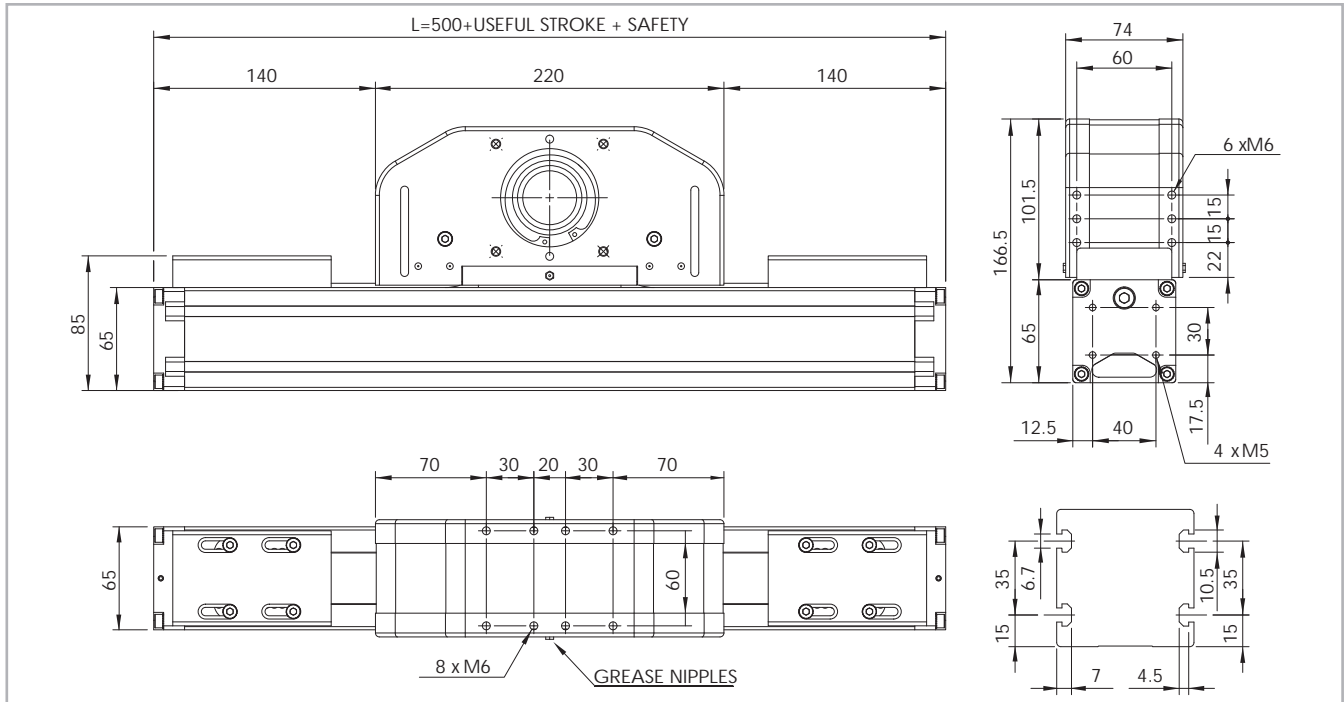

* The length of the safety stroke is provided on request according to the customer's specific requirements.

Fig. 39

Technical data

	Type
	S-SMART 65 SP
Max. useful stroke length [mm]	1500
Max. positioning repeatability [mm]*1	± 0.05
Max. speed [m/s]	4.0
Max. acceleration [m/s ²]	50
Type of belt	32 AT 5
Type of pulley	Z 32
Pulley pitch diameter [mm]	50.93
Carriage displacement per pulley turn [mm]	160
Carriage weight [kg]	3.6
Zero travel weight [kg]	7.3
Weight for 100 mm useful stroke [kg]	0.6
Starting torque [Nm]	0.60

*1) Positioning repeatability is dependent on the type of transmission used

Tab. 68

Moments of inertia of the aluminum body

Type	I_x [10 ⁷ mm ⁴]	I_y [10 ⁷ mm ⁴]	I_p [10 ⁷ mm ⁴]
S-SMART 65 SP	0.060	0.086	0.146

Tab. 69

Driving belt

The driving belt is manufactured from a friction resistant polyurethane and with steel cords for high tensile stress resistance.

Type	Type of belt	Belt width [mm]	Weight [kg/m]
S-SMART 65 SP	32 AT 5	32	0.105

Tab. 70

Belt length (mm) = L + 35

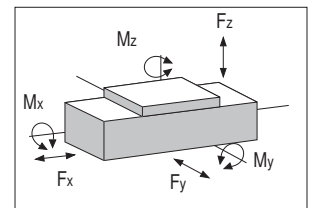

S-SMART 65 SP - Load capacity

Type	F_x [N]		F_y [N]		F_z [N]		M_x [Nm]		M_y [Nm]		M_z [Nm]	
	Stat.	Dyn.	Stat.	Dyn.	Stat.	Dyn.	Stat.	Dyn.	Stat.	Dyn.	Stat.	Dyn.
S-SMART 65 SP	1344	922	30560	19890	30560	19890	240	156	985	641	985	641

See verification under static load and lifetime on page SL-2 and SL-3

Tab. 71

> S-SMART 80 SP

S-SMART 80 SP Dimensions

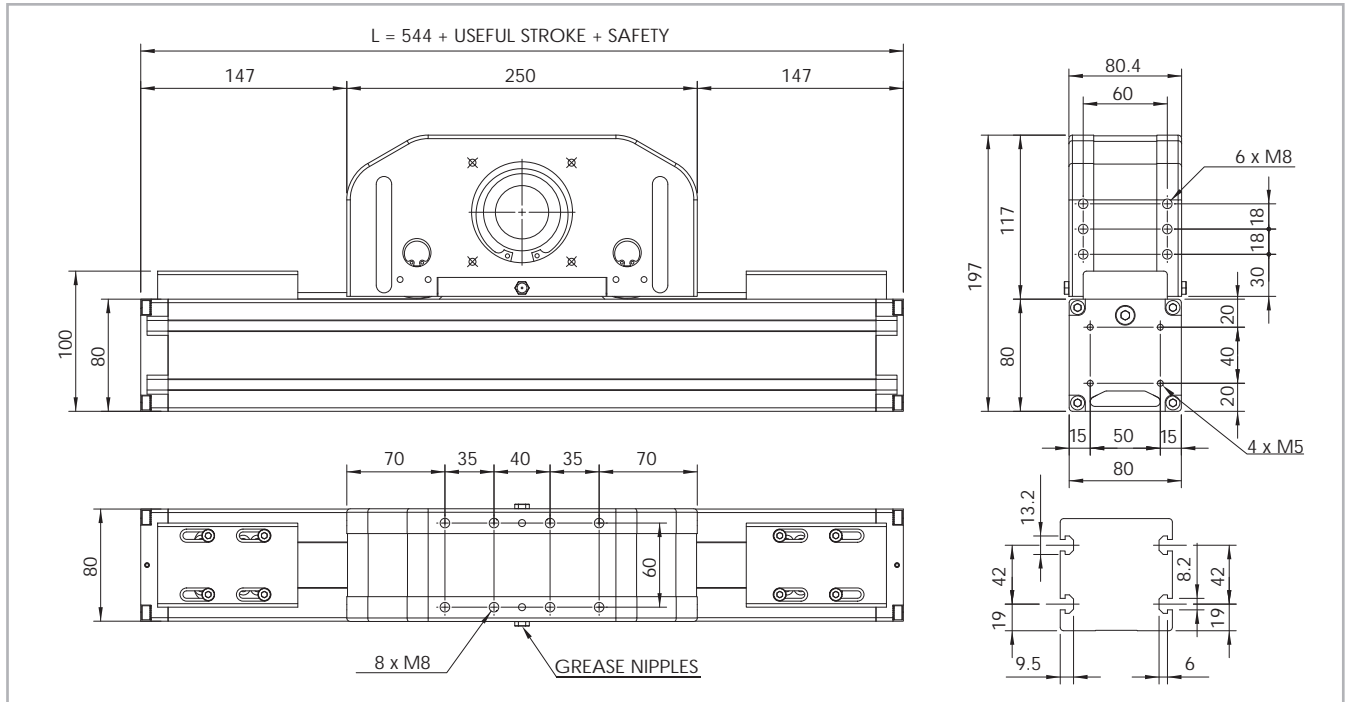

* The length of the safety stroke is provided on request according to the customer's specific requirements.

Fig. 40

Technical data

	Type
	S-SMART 80 SP
Max. useful stroke length [mm]	2000
Max. positioning repeatability [mm]*1	± 0.05
Max. speed [m/s]	4.0
Max. acceleration [m/s ²]	50
Type of belt	32 AT 10
Type of pulley	Z 21
Pulley pitch diameter [mm]	66.85
Carriage displacement per pulley turn [mm]	210
Carriage weight [kg]	6.3
Zero travel weight [kg]	12.6
Weight for 100 mm useful stroke [kg]	1
Starting torque [Nm]	1.65

*1) Positioning repeatability is dependent on the type of transmission used

Tab. 72

Moments of inertia of the aluminum body

Type	I_x [10 ⁷ mm ⁴]	I_y [10 ⁷ mm ⁴]	I_p [10 ⁷ mm ⁴]
S-SMART 80 SP	0.136	0.195	0.331

Tab. 73

Driving belt

The driving belt is manufactured from a friction resistant polyurethane and with steel cords for high tensile stress resistance.

Type	Type of belt	Belt width [mm]	Weight [kg/m]
S-SMART 80 SP	32 AT 10	32	0.186

Tab. 74

Belt length (mm) = L + 50

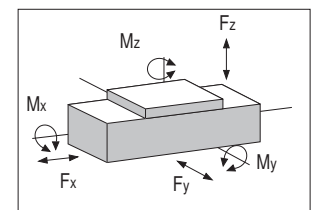

S-SMART 80 SP - Load capacity

Type	F_x [N]		F_y [N]		F_z [N]		M_x [Nm]		M_y [Nm]		M_z [Nm]	
	Stat.	Dyn.	Stat.	Dyn.	Stat.	Dyn.	Stat.	Dyn.	Stat.	Dyn.	Stat.	Dyn.
S-SMART 80 SP	2250	1459	51260	36637	51260	36637	520	372	3742	2675	3742	2675

See verification under static load and lifetime on page SL-2 and SL-3

Tab. 75

> Lubrication

SP linear units with ball bearing guides

The ball bearing carriages of the SP versions are fitted with a retention cage that eliminates "steel-steel" contact between adjacent revolving parts and prevents misalignment of these in the circuits.

This system guarantees a long interval between maintenances: SP version: every 5000 km or 1 year of use, based on the value reached first. If

a longer service life is required or in case of high dynamic or high loaded applications please contact our offices for further verification.

S-SMART

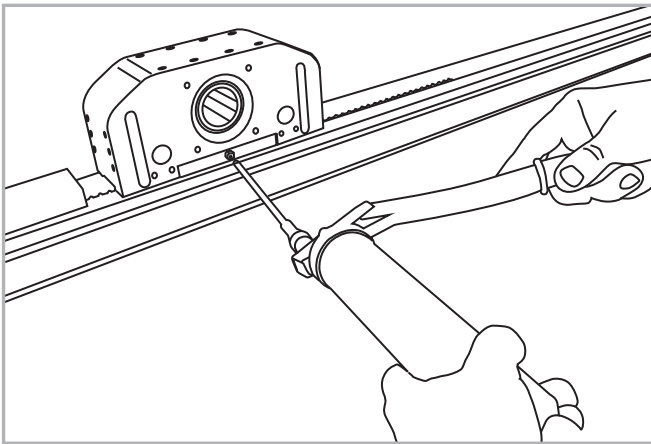

Fig. 41

- Insert the tip of the grease gun into the specific grease blocks.
- Type of lubricant: Lithium soap grease of class NLGI 2.
- For specially stressed applications or hostile environmental conditions, lubrication should be applied out more frequently.
Contact Rollon for further advice

Quantity of lubricant necessary for re-lubrication:

Type	Quantity of Grease (g)
S-SMART 50	2
S-SMART 65	2
S-SMART 80	5-6

Tab. 76

> Simple shafts

AS type simple shafts

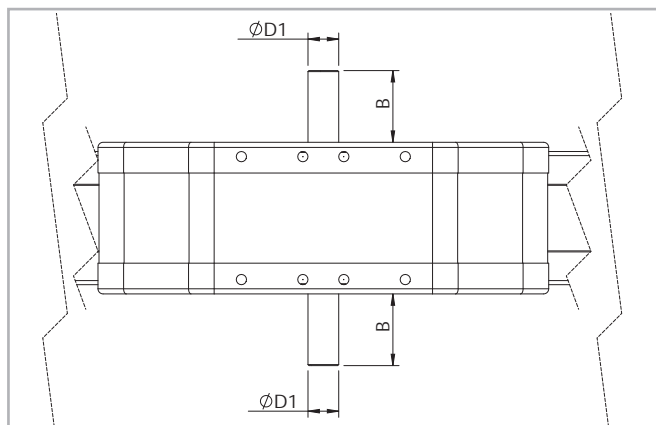

Position of the simple shaft can be to the right or to the left of the drive head.

Fig. 42

This head configuration is obtained by utilizing an assembly kit delivered as a separate accessory item.

Shaft can be installed on the left or right side of the drive head as decided by the customer.

Units (mm)

Applicable to unit	Shaft type	B	D1	AS Assembly kit code
S-SMART 50	AS 12	26	12h7	G000652
S-SMART 65	AS 15	35	15h7	G000851
S-SMART 80	AS 20	40	20h7	G000828

Tab. 77

> Hollow shaft

Hollow shaft type FP - Standard supply

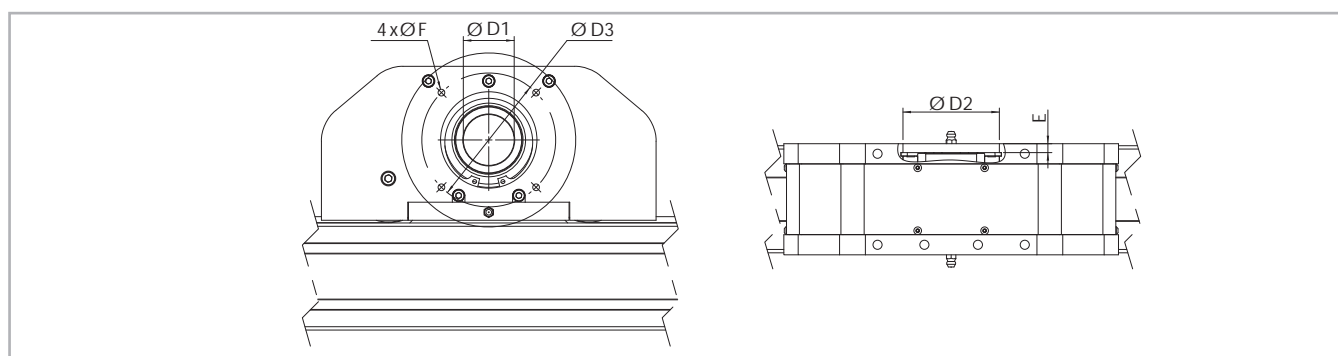

Fig. 43

Units (mm)

Applicable to unit	Shaft type	D1	D2	D3	E	F	Drive head code
S-SMART 50	FP 26	26H7	47J6	75	2.5	M5	2YA
S-SMART 65	FP 34	34H7	62J6	96	2.5	M6	2YA
S-SMART 80	FP 41	41H7	72J6	100	5	M6	2ZA

Tab. 78

An (optional) connection flange is required to fit the standard reduction units selected by Rollon.

For further information contact our offices.

> Accessories

The ball bearing guide linear drive system of Rollon SMART System series linear units enables them to support loads in any direction. They can therefore be installed in any position.

To install the SMART System series units, we recommend use of one of the systems indicated below:

T-nuts

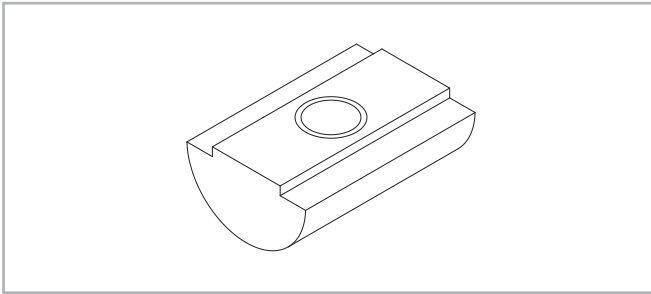

Steel nuts to be used in the slots of the body.

Fig. 44

Units (mm)

	Hole	Length	Code Rollon
S-SMART 50	M4	8	1001046
S-SMART 65	M5	10	1000627
S-SMART 80	M6	13	1000043

Tab. 79

Proximity

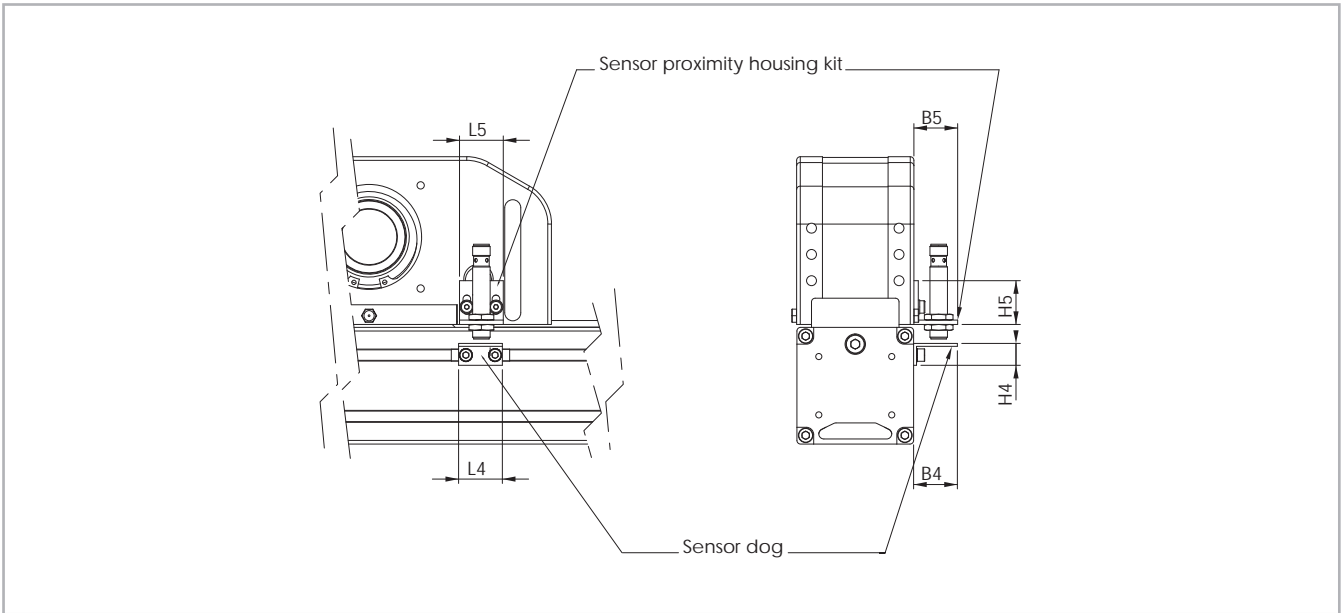

Fig. 45

Proximity switch holder

Aluminum block equipped with T-nuts for fixing

Proximity switch runner

Iron plate mounted on the carriage used for the proximity operation

Units (mm)

	B4	B5	L4	L5	H4	H5	For proximity	Sensor dog code	Sensor proximity housing code
S-SMART 50	30	30	30	30	15	30	Ø 8/12	G000835	G000834
S-SMART 65	30	30	30	30	15	30	Ø 8/12	G000836	G000834
S-SMART 80	30	30	30	30	15	30	Ø 8/12	G000837	G000834

Tab. 80

Assembly kits

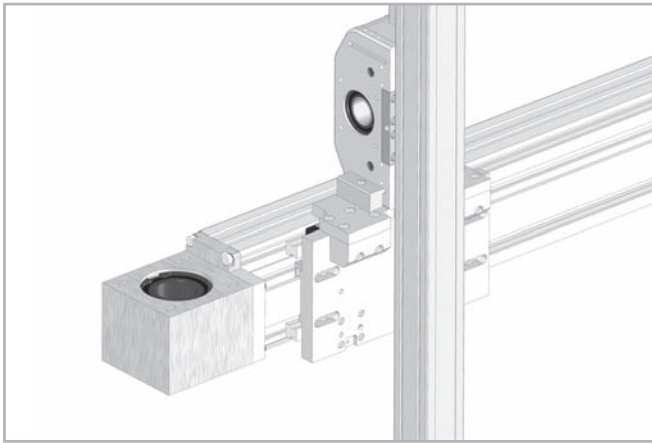

Fig. 46

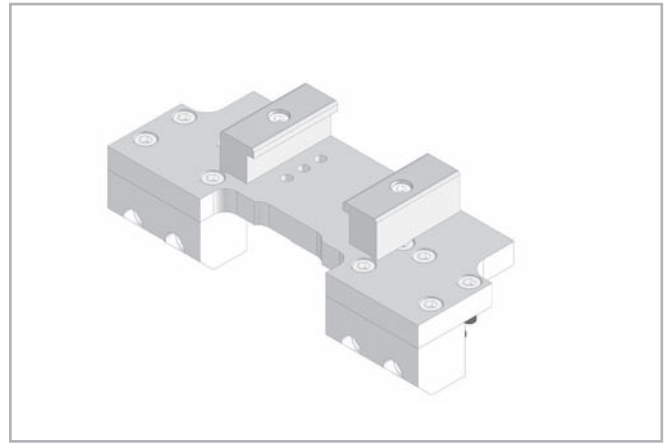











Fig. 47

While ordering two units for Y-Z assembly key has to be specified that they work together in order to drill the trolleys for the assembly of the kit.

Actuator combination Y-Z	Kit Code
 S-SMART 50 on E-SMART 50	G000647
 S-SMART 50 on R-SMART 120	G000910
 S-SMART 65 on E-SMART 50	G000654
 S-SMART 65 on E-SMART 80	G000677
 S-SMART 65 on R-SMART 120	G000911
 S-SMART 65 on R-SMART 160	G000912
 S-SMART 80 on E-SMART 80	G000653
 S-SMART 80 on E-SMART 100	G000688
 S-SMART 80 on R-SMART 120	G000990
 S-SMART 80 on R-SMART 160	G000913

Tab. 81

For examples of S-Smart on E-Smart see page SS-42

Adapter flange for gearbox assembly

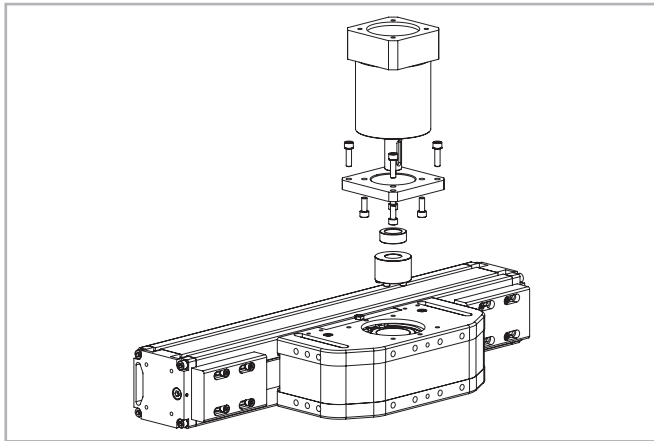

Fig. 48

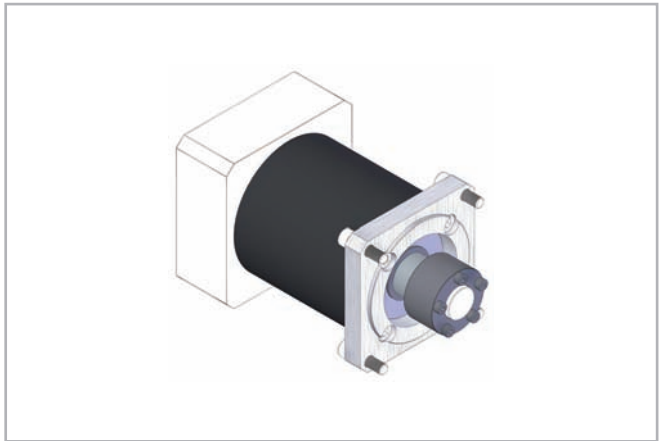

Fig. 49

Assembly kit includes: shrink disk; adapter plate; fixing hardware

Unit	Gearbox type (not included)	Kit Code
S-SMART 50	MP060	G000566
	PE2; LP050	G001444
S-SMART 65	MP080	G000529
	LC070	G000530
	MP060; PLE060	G000531
	SW030	G000748
	PE3; LP070	G000530
S-SMART 80	P3	G000824
	MP080	G000826
	LC090; MPV01; LP090; PE4	G000827
	PLE080	G000884
	SP060; PLN070	G000829
	SW040	G000866
	SW050	G000895

Tab. 82

For other gearbox type ask Rollon S.p.A.

Ordering key



> Identification codes for the S-SMART linear unit

F	08 05 = 50 06 = 65 08 = 80	2ZA	1300	1A 1A=SP	
					Linear motion system <i>see pg. SS-31</i>
			L=total length of the unit		
			Drive head code <i>see pg. SS-36</i>		
			Linear unit type <i>see from pg. SS-32 to pg. SS-34</i>		
			Linear unit series S-SMART <i>see pg. SS-29</i>		

In order to create identification codes for Actuator Line, you can visit: <http://configureactuator.rollon.com>

Multiaxis systems



Previously, customers wishing to build multiaxis units have had to design, draw and manufacture all the elements necessary to assemble two or more axes. Rollon now offers a set of components, including brackets and plates, to enable multiaxis units to be built.

In addition to the standard elements, Rollon can supply plates for special applications.

Application examples:

One axis system



A

A - X Axis: E-SMART

Two axis Y-Z system



C

C - Linear units: Y Axis 2 E-SMART - Z Axis 1 S-SMART

Connection kit:

Connection plate Kit for S-SMART (Z axis) on 2 E-SMART (Y axis)

Two parallel axis system

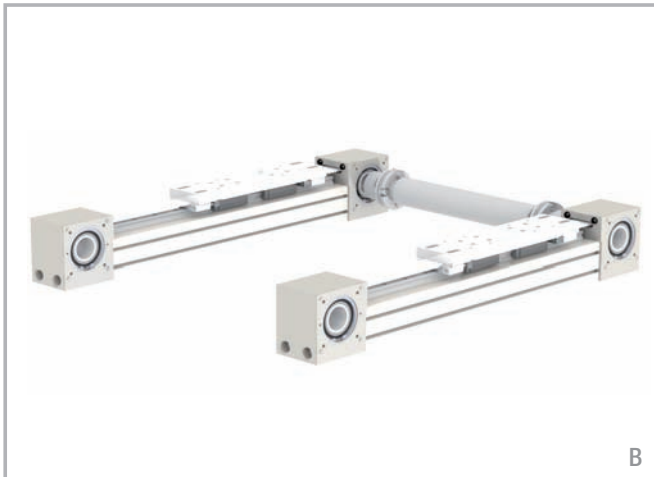

B

B - Linear units: 2 E-SMART

Connection kit: Parallel Kit

Three axis - X-Y-Z system

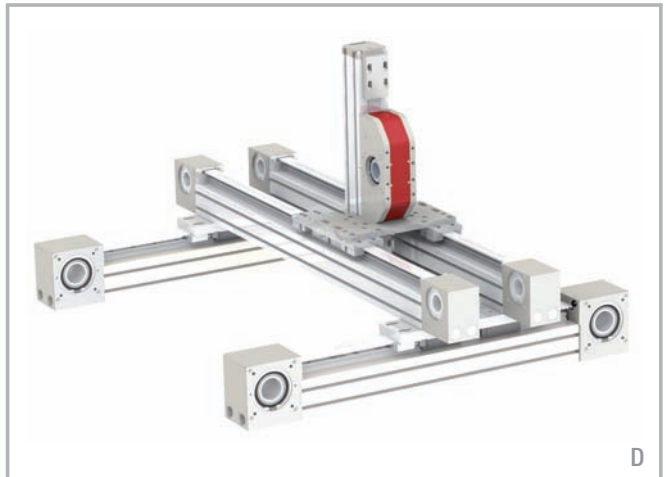

D

D - Linear units: X Axis 2 E-SMART - Y Axis 2 E-SMART - Z Axis 1 S-SMART

Connection kit: 2 fixing brackets Kit for 2 E-SMART (X axis) on 2 E-SMART (Y axis). Connection plate Kit for S-SMART (Z axis) on 2 E-SMART (Y axis). Parallel Kit

Two axis Y-Z system



E

E - Linear units: Y Axis 1 R-SMART - Z Axis 1 S-SMART
Connection kit: Connection plate Kit for S-SMART (Z axis) on R-SMART (Y axis).

Three axis X-Y-Z system



F

F - Linear units: X Axis 2 E-SMART - Y Axis 1 R-SMART - Z Axis 1 S-SMART
Connection kit: 2 fixing brackets Kit for 2 R-SMART (Y axis) on 2 E-SMART (X axis). Connection plate Kit for S-SMART (Z axis) on 2 R-SMART (Y axis). Parallel Kit

ROLLON[®]
Linear Evolution

Eco System

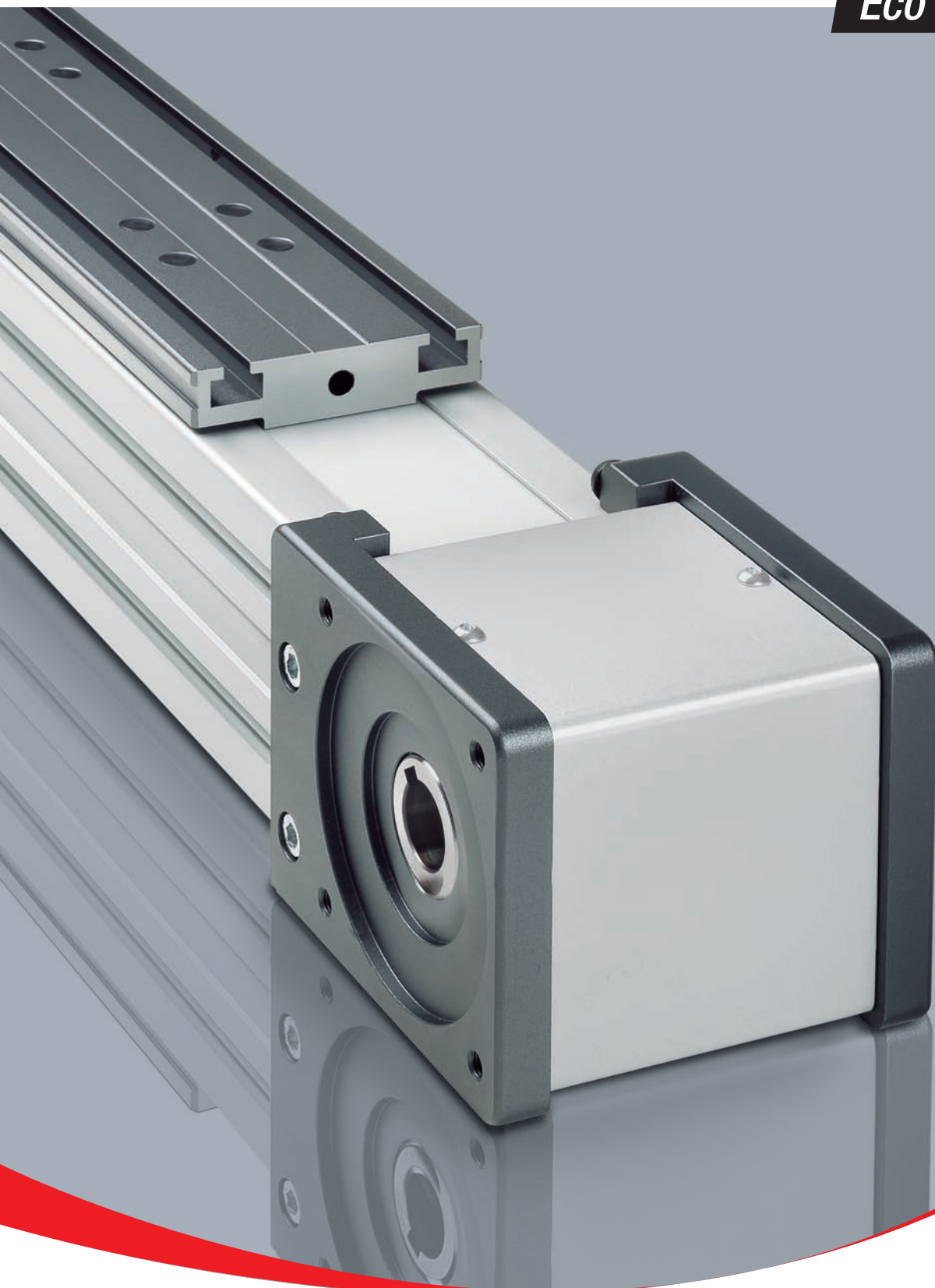

ECO series



> ECO series description

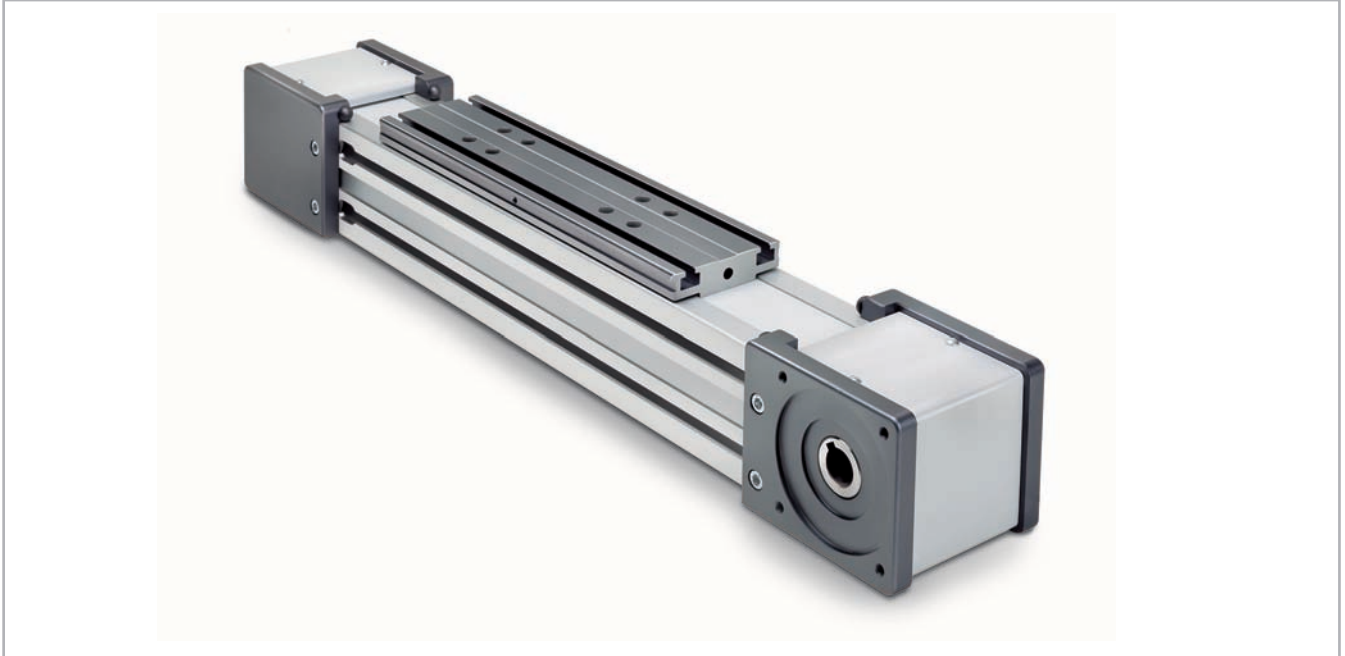

Fig. 1

The ECO SYSTEM units are linear actuators made of a self-supporting extruded aluminum frame and are driven by a polyurethane belt with AT metric profile steel inserts.

- Three different sizes available: 60mm, 80mm, 100mm
- Version available with recirculating ball bearing or roller rails
- Reduced weight ensured by the light frame and the aluminum sliders
- High sliding speed

The ECO SYSTEM series actuators are offered with two motion systems:

ECO SYSTEM – SP

Featuring a maintenance free recirculating linear guide rail fitted inside the profile.

ECO SYSTEM – CI

Featuring four rollers with a Gothic arch outer profile sliding on hardened steel bars placed inside the profile.

> The components

Extruded bodies

The anodised aluminum extrusion used for the profile of the Rollon ECO series linear units was designed and manufactured by industry experts to optimise weight while maintaining mechanical strength. The anodised aluminum alloy 6060 used (see physical-chemical characteristics below) was extruded with dimensional tolerances compliant with EN 755-9 standards.

Driving belt

The Rollon ECO series linear units use steel reinforced polyurethane drive belts with AT pitch. This belt is ideal due to its high load transmission characteristics, compact size and low noise. Used in conjunction with a backlash-free pulley, smooth alternating motion can be achieved.

Optimisation of the maximum belt width/body dimension ratio enables the following performance characteristics to be achieved:

- **High speed**
- **Low noise**
- **Low wear**

The driving belt is guided by specific slots in the aluminum extruded body thus covering the inside components.

Carriage

The carriage of the Rollon ECO series linear units is made of anodised aluminum. Two different length carriages are available for each type of linear unit.

General data about aluminum used: AL 6060

Chemical composition [%]

Al	Mg	Si	Fe	Mn	Zn	Cu	Impurites
Remainder	0.35-0.60	0.30-0.60	0.30	0.10	0.10	0.10	0.05-0.15

Tab. 1

Physical characteristics

Density	Coeff. of elasticity	Coeff. of thermal expansion (20°-100°C)	Thermal conductivity (20°C)	Specific heat (0°-100°C)	Resistivity	Melting point
$\frac{\text{kg}}{\text{dm}^3}$	$\frac{\text{kN}}{\text{mm}^2}$	$\frac{10^{-6}}{\text{K}}$	$\frac{\text{W}}{\text{m} \cdot \text{K}}$	$\frac{\text{J}}{\text{kg} \cdot \text{K}}$	$\Omega \cdot \text{m} \cdot 10^{-9}$	°C
2.70	69	23	200	880-900	33	600-655

Tab. 2

Mechanical characteristics

Rm	Rp (02)	A	HB
$\frac{\text{N}}{\text{mm}^2}$	$\frac{\text{N}}{\text{mm}^2}$	%	—
205	165	10	60-80

Tab. 3

> The linear motion system

The linear motion system has been designed to meet the load capacity, speed, and maximum acceleration conditions of a wide variety of applications. Two linear motion systems are offered:

ECO...SP with ball bearing guides

- A ball bearing guide with high load capacity is mounted in a dedicated seat on the inside of the aluminum body.
- The carriage is assembled on two pre-loaded ball bearing blocks.
- The two ball bearing blocks enable the carriage to withstand loading in the four main directions.
- The two blocks have seals on both sides and, if necessary, an additional scraper can be fitted for very dusty conditions.
- The ball bearing carriages of the SP versions are also fitted with a retention cage that eliminates "steel-steel" contact between adjacent revolving parts and prevents misalignment.
- Lubrication reservoirs (pockets) installed on the front of the ball bearing blocks supply the appropriate amount of grease, thus promoting a long maintenance interval.

The linear motion system described above offers:

- High speed and acceleration
- High load capacity
- High permissible bending moments
- Low friction
- Long life
- Maintenance Free (dependent on application)
- Low noise
- Suitable for long stroke

ECO...CI with gothic arch bearing guides inside the body

- Two hardened steel rods (58/60 HRC tolerance h6) are securely inserted inside the aluminum body.
- The carriage is fitted with six bearing assemblies each having a gothic arch groove machined into its outer race to run on the steel rods.
- The six bearings are mounted on steel pins, two of which are eccentric, to allow setting of running clearance and pre-load.
- To keep the running tracks clean and lubricated, four grease impregnated felt seals, complete with grease reservoirs, are fitted on the ends of the carriage.
- The driving belt is supported by the entire length of the profile in order to avoid deflection as well as to protect the linear guide.

The linear motion system described above offers:

- Good positioning accuracy
- Low noise
- Maintenance Free (dependent on application)

ECO SP

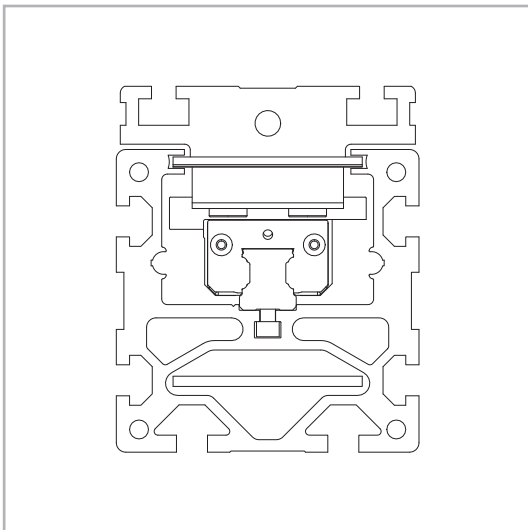

Fig. 2

ECO CI

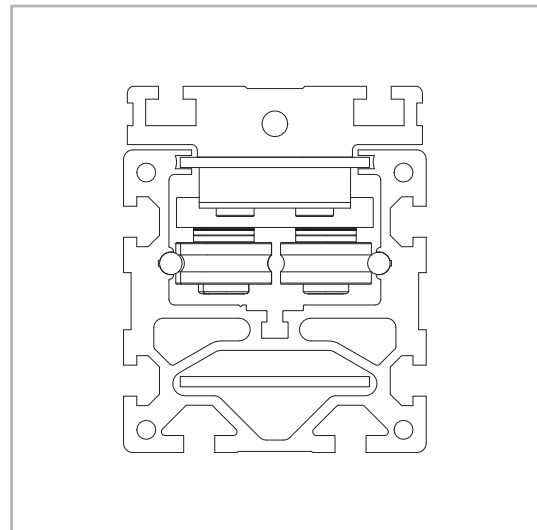
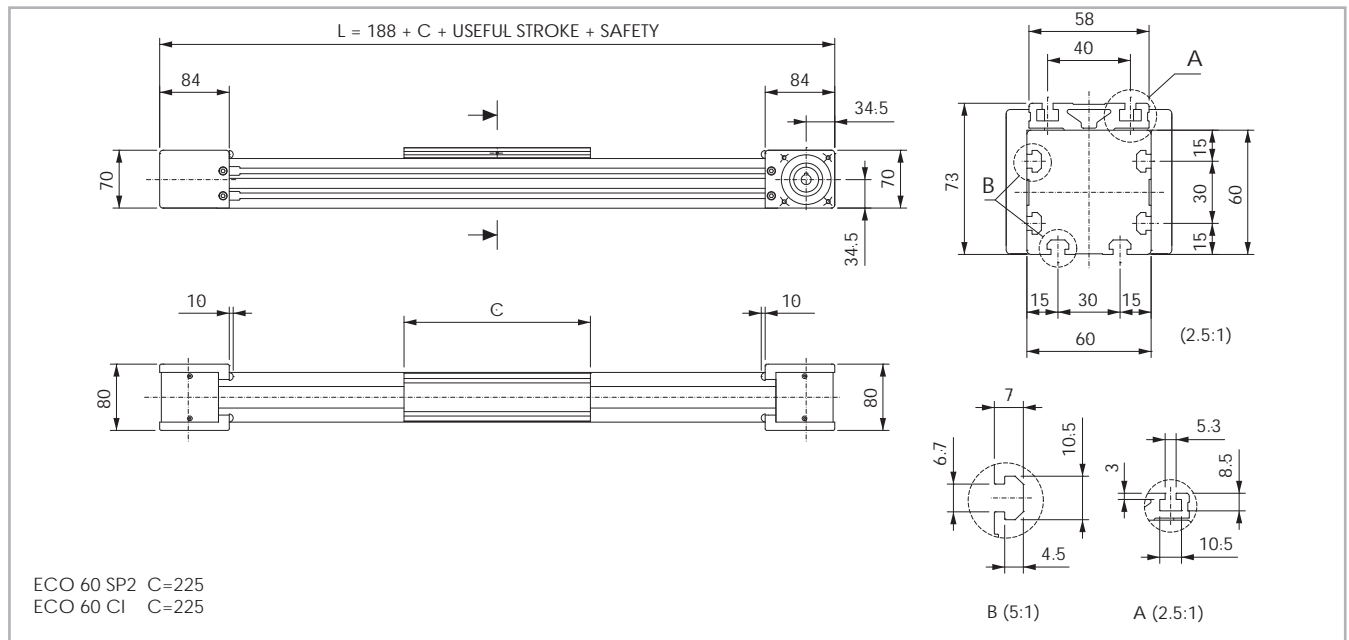

Fig. 3

> ECO 60 SP2 - ECO 60 CI

ECO 60 SP2 - ECO 60 CI Dimensions



* The length of the safety stroke is provided on request according to the customer's specific requirements.

Fig. 4

Technical data

	Type	
	ECO 60 SP2	ECO 60 CI
Max. useful stroke length [mm]	3700	6000
Max. positioning repeatability [mm]*1	± 0.05	± 0.05
Max. speed [m/s]	4.0	1.5
Max. acceleration [m/s ²]	50	1.5
Type of belt	32 AT 5	32 AT 5
Type of pulley	Z 28	Z 28
Pulley pitch diameter [mm]	44.56	44.56
Carriage displacement per pulley turn [mm]	140	140
Carriage weight [kg]	0.51	0.80
Zero travel weight [kg]	3.5	3.2
Weight for 100 mm useful stroke [kg]	0.45	0.68
Starting torque [Nm]	0.24	0.32
Moment of inertia of pulleys [g mm ²]	163000	163000

*1) Positioning repeatability is dependent on the type of transmission used

Tab. 4

Moments of inertia of the aluminum body

Type	I_x [10 ⁷ mm ⁴]	I_y [10 ⁷ mm ⁴]	I_p [10 ⁷ mm ⁴]
ECO 60	0.037	0.054	0.093

Tab. 5

Driving belt

The driving belt is manufactured with friction resistant polyurethane, with steel cord reinforcement for high tensile stress resistance.

Type	Type of belt	Belt width [mm]	Weight kg/m
ECO 60	32 AT 5	32	0.105

Tab. 6

Belt length (mm) SP2/CI = 2 x L - 166

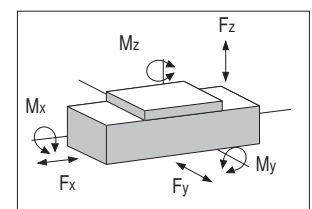

ECO 60 SP2 - ECO 60 CI - Load capacity

Type	F_x [N]		F_y [N]		F_z [N]		M_x [Nm]		M_y [Nm]		M_z [Nm]	
	Stat.	Dyn.	Stat.	Dyn.	Stat.	Dyn.	Stat.	Dyn.	Stat.	Dyn.	Stat.	Dyn.
ECO 60 SP2	1360	1020	6930	4616	6930	4616	43	29	319	212	319	212
ECO 60 CI	1360	1020	1480	2540	910	1410	20	30	50	78	82	140

See verification under static load and lifetime on page SL-2 and SL-3

Tab. 7

> ECO 80 SP2 - ECO 80 SP1 - ECO 80 CI

ECO 80 SP2 - ECO 80 SP1 - ECO 80 CI Dimensions

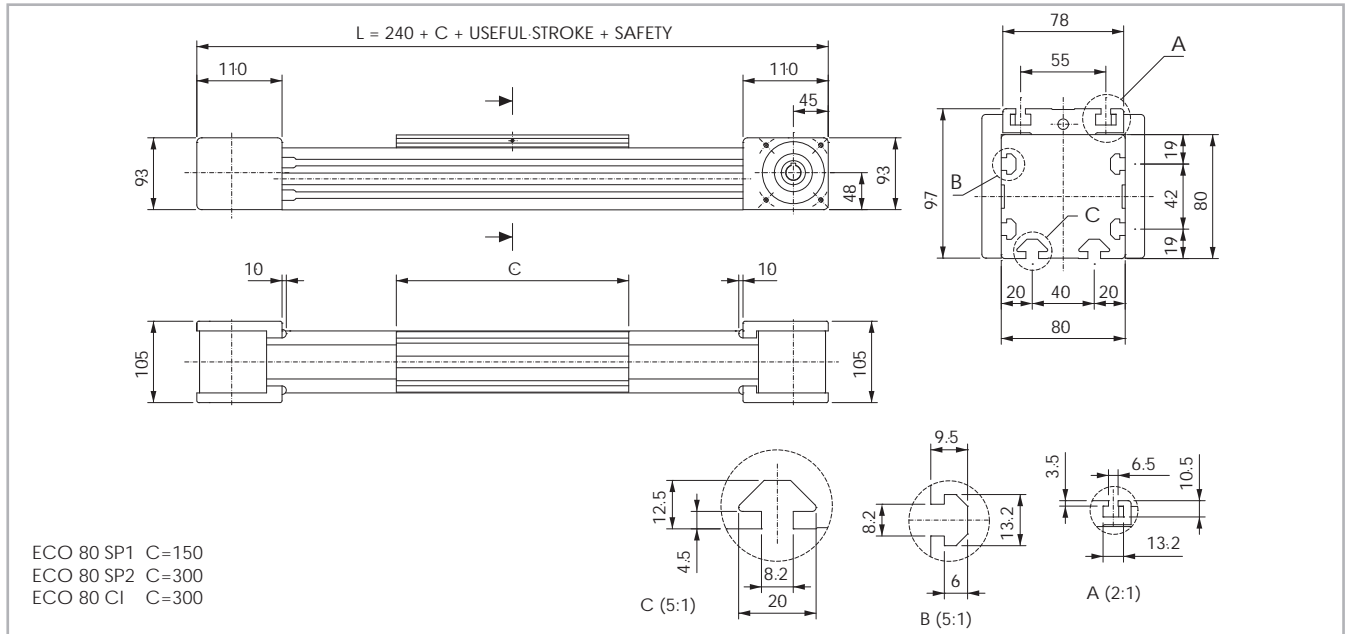

* The length of the safety stroke is provided on request according to the customer's specific requirements.

Fig. 5

Technical data

	Type		
	ECO 80 SP2	ECO 80 SP1	ECO 80 CI
Max. useful stroke length [mm]	6000	6000	6000
Max. positioning repeatability [mm]*1	± 0.05	± 0.05	± 0.05
Max. speed [m/s]	5.0	5.0	1.5
Max. acceleration [m/s ²]	50	50	1.5
Type of belt	50 AT 5	50 AT 5	50 AT 5
Type of pulley	Z 37	Z 37	Z 37
Pulley pitch diameter [mm]	58.89	58.89	58.89
Carriage displacement per pulley turn [mm]	185	185	185
Carriage weight [kg]	1.6	0.9	2.1
Zero travel weight [kg]	7.7	5.9	8.2
Weight for 100 mm useful stroke [kg]	0.8	0.8	0.65
Starting torque [Nm]	0.75	0.75	0.75
Moment of inertia of pulleys [g mm ²]	706000	706000	706000

*1) Positioning repeatability is dependant on the type of transmission used

Tab. 8

Moments of inertia of the aluminum body

Type	I_x [10 ⁷ mm ⁴]	I_y [10 ⁷ mm ⁴]	I_p [10 ⁷ mm ⁴]
ECO 80	0.117	0.173	0.280

Tab. 9

Driving belt

The driving belt is manufactured with friction resistant polyurethane, with steel cord reinforcement for high tensile stress resistance.

Type	Type of belt	Belt width [mm]	Weight kg/m
ECO 80	50 AT 5	50	0.164

Tab. 10

Belt length (mm) SP2/CI = 2 x L - 240

SP1 = 2 x L - 90

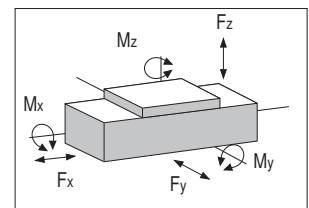

ECO 80 SP2 - ECO 80 SP1 - ECO 80 CI - Load capacity

Type	F_x [N]		F_y [N]		F_z [N]		M_x [Nm]		M_y [Nm]		M_z [Nm]	
	Stat.	Dyn.	Stat.	Dyn.	Stat.	Dyn.	Stat.	Dyn.	Stat.	Dyn.	Stat.	Dyn.
ECO 80 SP2	2120	1590	24200	14560	24200	14560	240	138	1706	1026	1706	1026
ECO 80 SP1	2120	1590	12100	7280	12100	7280	120	69	66	37	66	37
ECO 80 CI	2120	1590	3800	7340	2470	4080	68	110	210	340	320	610

See verification under static load and lifetime on page SL-2 and SL-3

Tab. 11

> ECO 100 SP2 - ECO 100 SP1 - ECO 100 CI

ECO 100 SP2 - ECO 100 SP1 - ECO 100 CI Dimensions

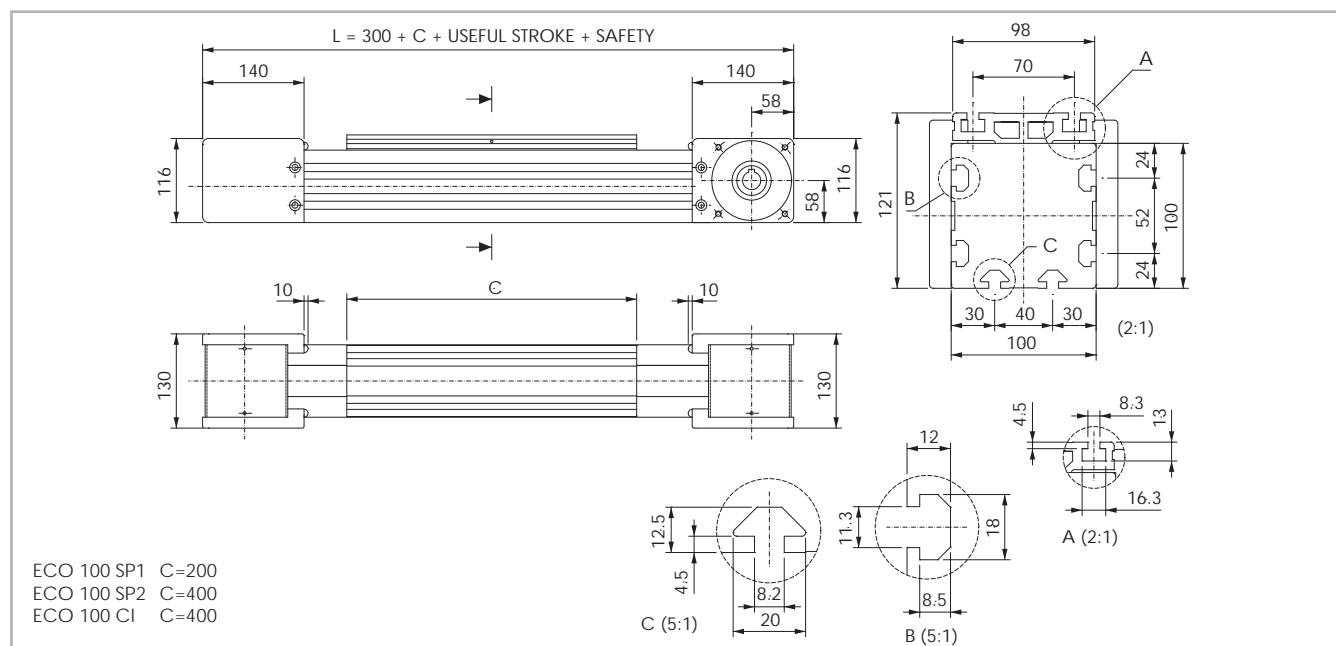

* The length of the safety stroke is provided on request according to the customer's specific requirements.

Fig. 6

Technical data

	Type		
	ECO 100 SP2	ECO 100 SP1	ECO100 CI
Max. useful stroke length [mm]	6000	6000	6000
Max. positioning repeatability [mm]*1	± 0.05	± 0.05	± 0.05
Max. speed [m/s]	5.0	5.0	1.5
Max. acceleration [m/s ²]	50	50	1.5
Type of belt	50 AT 10	50 AT 10	50 AT 10
Type of pulley	Z 24	Z 24	Z 24
Pulley pitch diameter [mm]	76.39	76.39	76.39
Carriage displacement per pulley turn [mm]	240	240	240
Carriage weight [kg]	2.9	1.5	3.3
Zero travel weight [kg]	16.7	12.5	17.1
Weight for 100 mm useful stroke [kg]	1.3	1.3	1.1
Starting torque [Nm]	1.90	1.35	1.35
Moment of inertia of pulleys [g mm ²]	2070000	2070000	2070000

*1) Positioning repeatability is dependant on the type of transmission used

Tab. 12

ECO 100 SP2 - ECO 100 SP1 - ECO 100 CI - Load capacity

Type	F _x [N]		F _y [N]		F _z [N]		M _x [Nm]		M _y [Nm]		M _z [Nm]	
	Stat.	Dyn.	Stat.	Dyn.	Stat.	Dyn.	Stat.	Dyn.	Stat.	Dyn.	Stat.	Dyn.
ECO 100 SP2	4410	3310	43400	34800	43400	34800	570	440	4297	3445	4297	3445
ECO 100 SP1	4410	3310	21700	17400	21700	17400	285	220	155	120	155	120
ECO 100 CI	4410	3310	8500	17000	4740	8700	160	300	520	950	930	1850

See verification under static load and lifetime on page SL-2 and SL-3

Tab. 15

Moments of inertia of the aluminum body

Type	I _x [10 ⁷ mm ⁴]	I _y [10 ⁷ mm ⁴]	I _p [10 ⁷ mm ⁴]
ECO 100	0.342	0.439	0.781

Tab. 13

Driving belt

The driving belt is manufactured with friction resistant polyurethane, with steel cord reinforcement for high tensile stress resistance.

Type	Type of belt	Belt width [mm]	Weight kg/m
ECO 100	50 AT 10	50	0.290

Tab. 14

Belt length (mm) SP1 = 2 x L - 112

SP2/CI = 2 x L - 312

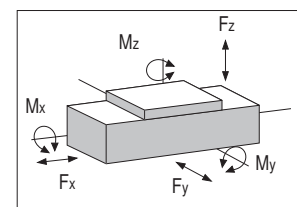

> Simple shafts

AS type simple shafts

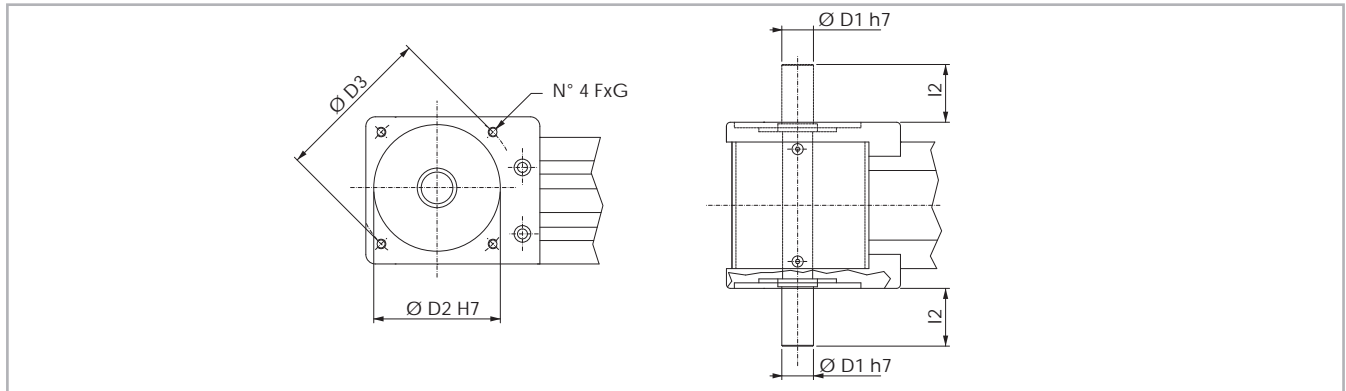

Position of the simple shaft can be to the left or right of the drive head.

Fig. 7

Dimensions (mm)

Applicable to unit	Shaft type	D1	D2	D3	I2	F	G	Head code AS left	Head code AS right
ECO 60	AS 12	12	60	75	25	M5	12	2G	2I
ECO 80	AS 20	20	80	100	36.5	M6	16	2G	2I
ECO 100	AS 25	25	110	130	50	M8	20	2G	2I

Tab. 16

> Hollow shafts

Transmission of torque to the drive pulley

Torque is transmitted to the drive pulley from a hollow shaft and keyway. This system may create backlash in the case of alternating loads and high level acceleration. For further information, contact our offices.

Hollow shaft

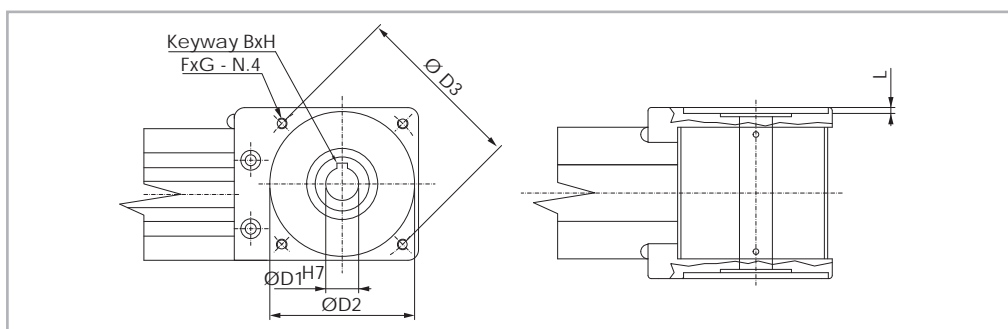

Fig. 8

An (optional) connection flange is required to fit the standard reduction units selected by Rollon. For further information, contact our offices

Unit	Shaft type	D1	D2	D3	L	Key way BxH	F	G	Drive head code
ECO 60	AC 12	12H7	60J6	75	3.5	4 x 4	M5	12	2A
ECO 80	AC 19	19H7	80J6	100	3.5	6 x 6	M6	16	2A
ECO 100	AC 25	25H7	110J6	130	4.5	8 x 7	M8	20	2A

Tab. 17

> Linear units in parallel

Synchronisation kit for use of ECO linear units in parallel

When movement consisting of two linear units in parallel is essential, a synchronisation kit must be used. The kit contains original Rollon blade type precision joints complete with tapered splines and hollow aluminum drive shafts.

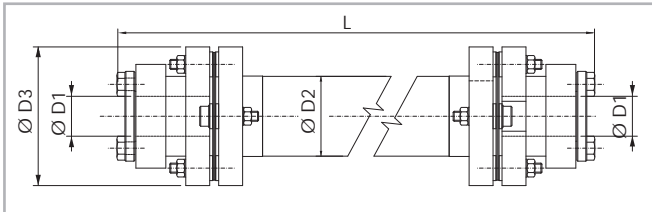

Fig. 9

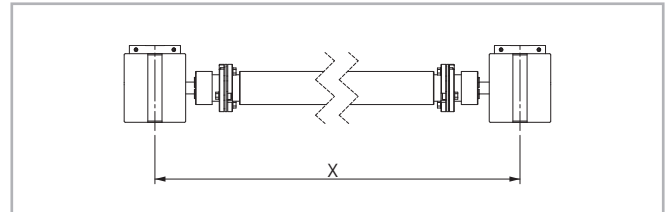

Fig. 10

Unit	Shaft type	D1	D2	D3	Code	Formula for length calculation
ECO 60	AP 12	12	25	45	GK12P...1A	$L = X - 88$ [mm]
ECO 80	AP 20	20	40	69.5	GK20P...1A	$L = X - 116$ [mm]
ECO 100	AP 25	25	70	99	GK25P...1A	$L = X - 165$ [mm]

Tab. 18

> Accessories

Fixing by brackets

The linear motion systems used for the Rollon ECO series linear units enables them to support loads in any direction. They can therefore be installed in any position.

To install the units, we recommend use of the dedicated T-slots in the aluminum extruded bodies as shown below.

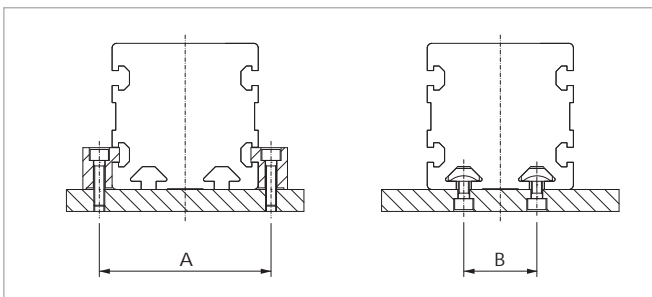
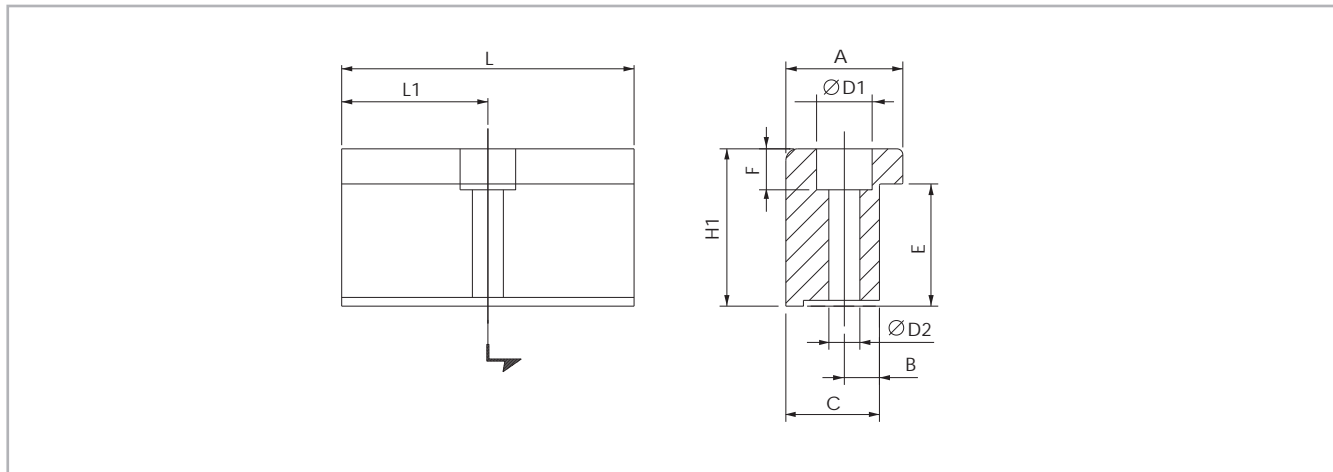

Fig. 11

Unit	A (mm)	B (mm)
ECO 60	72	30
ECO 80	94	40
ECO 100	120	40

Tab. 19

Fixing brackets



Anodised aluminum block for fixing the linear units through the side slots of the body

Fig. 12

Unit	A	H1	B	C	E	F	D1	D2	L	L1	Code
ECO 60	20	17.5	6	16	11.5	6	9.4	5.3	50	25	1001490
ECO 80	20	20.7	7	16	14.7	7	11	6.4	50	25	1001491
ECO 100	36.5	28.5	10	31	18.5	11.5	16.5	10.5	100	50	1001233

Tab. 20

T-nuts

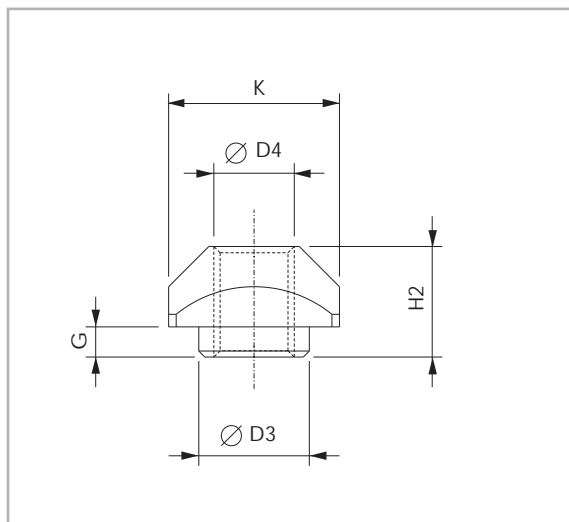

Steel nuts to be used in the slots of the body.

Fig. 13

Dimensions (mm)

Unit		D3	D4	G	H2	K	Code
ECO 60	L	6.7	M5	2.3	6.5	10	1000627
ECO 60	C	-	M5	-	5	10	1000620
ECO 80	L	8	M6	3.3	8.3	13	1000043
ECO 80	C	-	M6	-	5.8	13	1000910
ECO 80	I	-	M6	-	6.5	17	1000911
ECO 100	L	11	M8	3	11	17	1000932
ECO 100	C	-	M8	-	8	16	1000942
ECO 100	I	-	M8	-	6.5	17	1000943

L = Side - C = Carriage - I = Lower

Tab. 21

Proximity

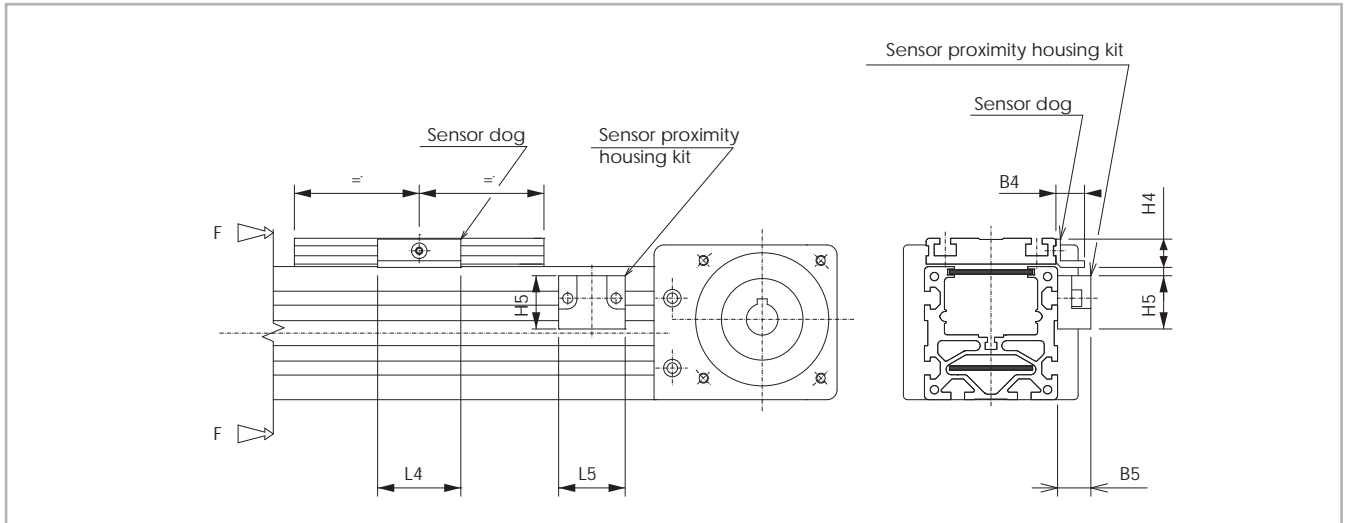

Fig. 14

Sensor proximity housing kit

Anodized aluminum block, red colour, equipped with T-nuts for fixing into the body slots.

Sensor dog

L-shaped bracket in zinc-plated iron, mounted on the carriage and used for the proximity switch operation.

Unit	B4	B5	L4	L5	H4	H5	For proximity	Sensor dog Code	Sensor proximity housing kit code
ECO 60	9.5	14	25	29	12	22.5	Ø 8	G000268	G000213
ECO 80	17.2	20	50	40	17	32	Ø 12	G000267	G000209
ECO 100	17.2	20	50	40	17	32	Ø 12	G000267	G000210

Tab. 22

Ordering key

> Identification codes for the ECO linear unit

C	06 06=60 08=80 10=100	2A	0 2000	1A 1A=SP1 2A=SP2 1C=CI	
					Linear motion system <i>see pg. ES-4</i>
					L=total length of the unit
					Driving head code <i>see pg. ES-8</i>
					Linear unit size <i>see from pg. ES-5 to pg. ES-7</i>
					ECO series <i>see pg. ES-2</i>

In order to create identification codes for Actuator Line, you can visit: <http://configureactuator.rollon.com>

Multiaxis systems



Previously, customers wishing to build multiaxis units have had to design, draw and manufacture all the elements necessary to assemble two or more axis. Rollon now offers a set of fittings including brackets and cross plates to enable multiaxis units to be built. In addition to standard elements, Rollon also provides plates for special applications.

ECO axis system



A

A - Linear units: X axis 1 ECO 80

Two axis X-Y system

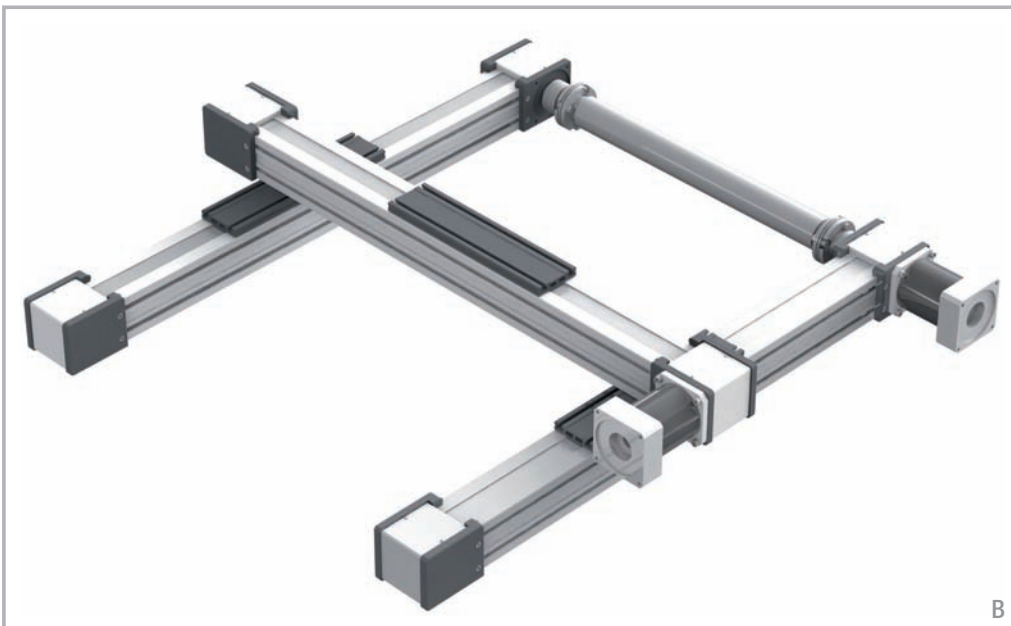

B

B - Linear units: X axis: 2 ECO 80 - Y axis 1 ECO 80

Connection kit: 2 Kits of fixing brackets for the ECO 80 unit (Y axis) on the carriages of the ECO 80 units (X axis).

ROLLON[®]
Linear Evolution

Uniline System



Uniline A series



> Uniline A series description



Fig. 1

Uniline is a family of ready-to-install linear actuators. They consist of internal Compact Rail roller sliders and steel-reinforced polyurethane belts in a rigid aluminum profile. Longitudinal seals enclose the system. This arrangement provides the best protection for the actuator from soiling and damage. In the A series, the fixed bearing rail (T-rail) is mounted horizontally in the aluminum profile. Versions with long (L) or double (D) sliders in one axis are possible.

The most important characteristics:

- Compact design
- Protected internal linear guides
- High traversing speeds
- Grease-free operation possible (depending on the application. For further information, please contact our Application Engineering department)
- High versatility
- Long strokes
- Versions with long or multiple sliders available in one linear axis

Preferred areas of application:

- Handling and automation
- Multi-axis gantries
- Packaging machines
- Cutting machines
- Displaceable panels
- Painting installations
- Welding robots
- Special machines

Technical data:

- Available sizes [mm]:
Type A: 40, 55, 75, 100
- Length and stroke tolerances:
For strokes <1 m: +0 mm to +10 mm (+0 in to 0.4 in)
For strokes >1 m: +0 mm to +15 mm (+0 in to 0.59 in)

> The components

Extruded profile

The anodized 6060 aluminum alloy extrusion used for the profile of the Rollon Uniline A series linear units were designed and manufactured by industry experts to optimize weight while maintaining mechanical strength. (see physical-chemical characteristics below). The dimensional tolerances comply with EN 755-9 standard.

Driving belt

The Rollon Uniline A series linear units use steel reinforced polyurethane drive belts with RPP pitch and parabolic profiles. This belt is ideal due to its high load transmission characteristics, compact size and low noise. Used in conjunction with a backlash-free pulley, smooth alternating motion can

be achieved. Optimization of the maximum belt width/body dimension ratio enables the following performance characteristics to be achieved:

- High speed
- Low noise
- Low wear

Carriage

The carriage of the Rollon Uniline A series linear units are made entirely of anodized aluminum. Each carriage has mounting T-slots for the connection to the moving element (size 40 has threaded holes). Rollon offers multiple carriages to accommodate a vast array of applications.

General data about aluminum used: AL 6060

Chemical composition [%]

Al	Mg	Si	Fe	Mn	Zn	Cu	Impurites
Remainder	0.35-0.60	0.30-0.60	0.30	0.10	0.10	0.10	0.05-0.15

Tab. 1

Physical characteristics

Density	Coeff. of elasticity	Coeff. of thermal expansion (20°-100°C)	Thermal conductivity (20°C)	Specific heat (0°-100°C)	Resistivity	Melting point
$\frac{\text{kg}}{\text{dm}^3}$	$\frac{\text{kN}}{\text{mm}^2}$	$\frac{10^{-6}}{\text{K}}$	$\frac{\text{W}}{\text{m} \cdot \text{K}}$	$\frac{\text{J}}{\text{kg} \cdot \text{K}}$	$\Omega \cdot \text{m} \cdot 10^{-9}$	°C
2.7	69	23	200	880-900	33	600-655

Tab. 2

Mechanical characteristics

Rm	Rp (02)	A	HB
$\frac{\text{N}}{\text{mm}^2}$	$\frac{\text{N}}{\text{mm}^2}$	%	—
205	165	10	60-80

Tab. 3

> A40

A40 system

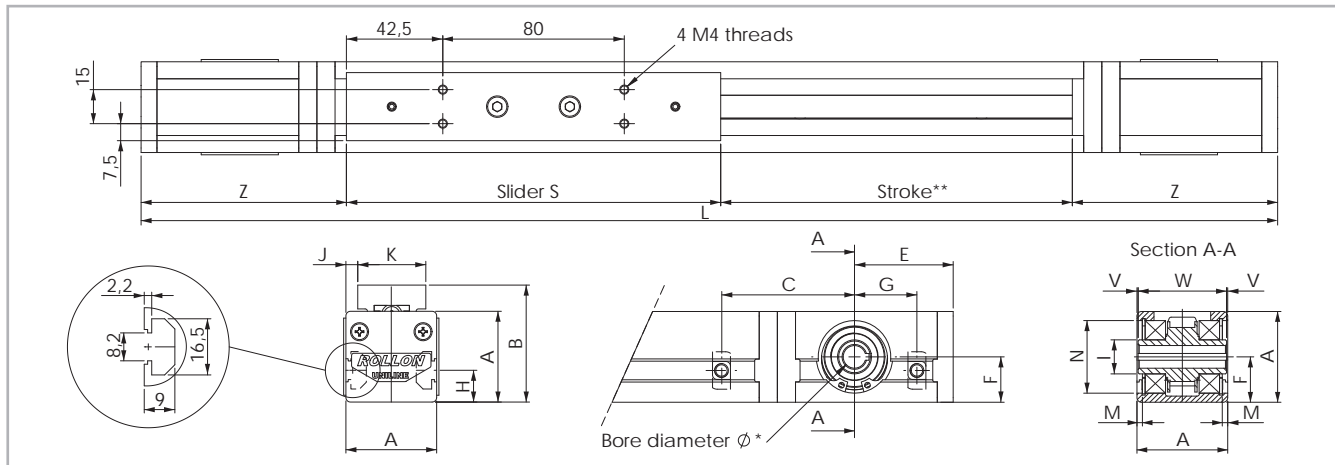

* For information on the motor connection bores, see ordering key. ** The length of the safety stroke is provided on request according to the customer's specific requirements. **Fig. 2**

Type	A [mm]	B [mm]	C* [mm]	E [mm]	F [mm]	G* [mm]	H [mm]	I [mm]	J [mm]	K [mm]	M [mm]	N [mm]	S [mm]	V [mm]	W [mm]	Z [mm]	Stroke** [mm]
A40	40	51.5	57	43.5	20	26	14	Ø 14,9	5	30	2.3	Ø 32	165	0.5	39	91.5	1900

* For the position of the T-nuts when using our motor adapter plates, see pg. US-15ff
 ** Maximum stroke for a single-piece guiding rail. For longer strokes, see tab. 9 **Tab. 4**

A40L with long slider

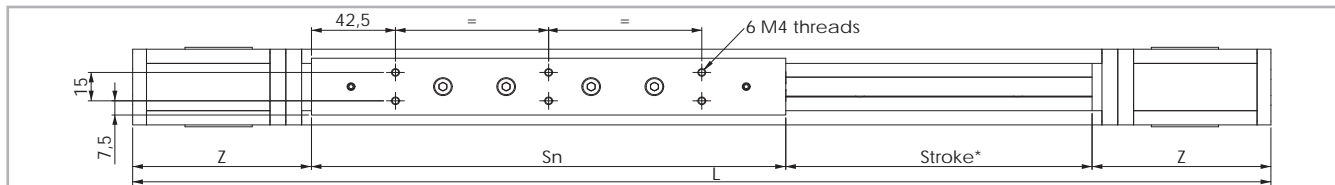

* The length of the safety stroke is provided on request according to the customer's specific requirements. **Fig. 3**

Type	S _{min} [mm]	S _{max} [mm]	Sn [mm]	Z [mm]	Stroke* [mm]
A40L	240	400	$S_n = S_{min} + n \cdot 10$	91.5	1660

* Maximum stroke for a single-piece guiding rail and a maximum slider plate length S_{max}
 For longer strokes, see tab. 9 **Tab. 5**

A40D with double slider

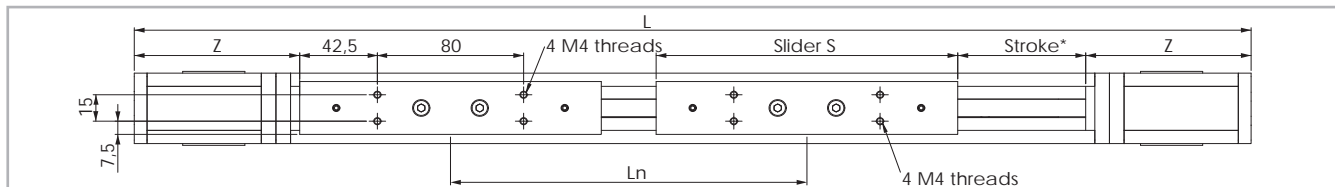

* The length of the safety stroke is provided on request according to the customer's specific requirements. **Fig. 4**

Type	S [mm]	L _{min} [mm]	L _{max} ** [mm]	Ln [mm]	Z [mm]	Stroke* [mm]
A40D	165	235	1900	$L_n = L_{min} + n \cdot 5$	91.5	1660

* Maximum stroke for a single-piece guiding rail and a minimum slider plate distance L_{min}
 ** Maximum distance L_{max} between the centres of slider plates at a stroke of 0 mm
 For longer strokes, see tab. 9 **Tab. 6**

> Load ratings, moments and characteristic data

A40

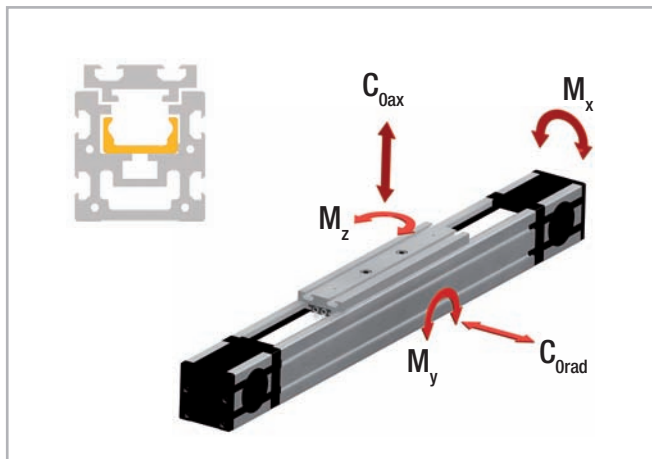

Fig. 5

Driving belt

The driving belt is manufactured from a friction resistant polyurethane and with steel cords for high tensile stress resistance.

Type	Type of belt	Belt width [mm]	Weight kg/m
A40	10RPP5	10	0.041

Tab. 7

Belt length (mm) = 2 x L - 168 Standard slider

Belt length (mm) = 2 x L - S_n-3 Long slider

Belt length (mm) = 2 x L - L_n - 168 Double slider

Type	C [N]	C _{0rad} [N]	C _{0ax} [N]	M _x [Nm]	M _y [Nm]	M _z [Nm]
A40	1530	820	300	2.8	5.6	13.1
A40-L	3060	1640	600	5.6	22 to 70	61 to 192
A40-D	3060	1640	600	5.6	70 to 570	193 to 1558

For the calculation of the allowed moments, please observe pages SL-5ff

Tab. 8

Technical data	Type
	A40
Standard belt tension [N]	160
Moment at no load [Nm]	0.14
Max. traversing speed [m/s]	3
Max. acceleration [m/s ²]	10
Repeat accuracy [mm]	0.1
Linear accuracy [mm]	0.8
Compact Rail guiding rail	TLV18
Slider type	CS18 spec.
Moment of inertia I _y [cm ⁴]	12
Moment of inertia I _z [cm ⁴]	13.6
Pitch diameter of pulley [m]	0.02706
Moment of inertia of each pulley [gmm ²]	5055
Stroke per shaft revolution [mm]	85
Mass of slider [g]	220
Weight with zero stroke [g]	1459
Weight with 1 m stroke [g]	3465
Max. stroke [mm]	3500
Working temperature	from -20 °C to + 80 °C

Tab. 9

> A55

A55 system

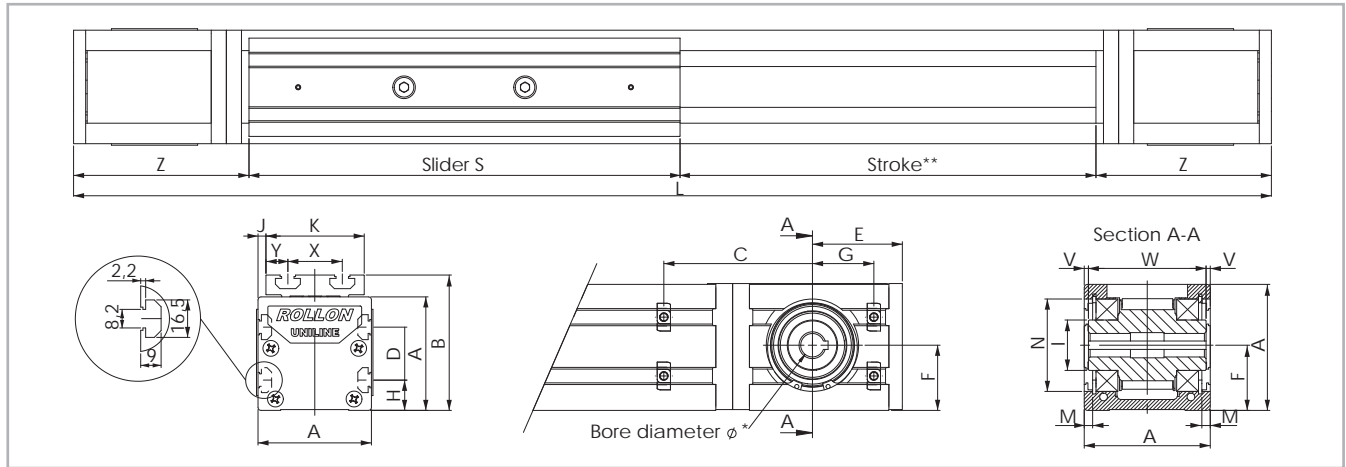

* For information on the motor connection bores, see ordering key. ** The length of the safety stroke is provided on request according to the customer's specific requirements. Fig. 6

Type	A [mm]	B [mm]	C* [mm]	D [mm]	E [mm]	F [mm]	G* [mm]	H [mm]	I [mm]	J [mm]	K [mm]	M [mm]	N [mm]	S [mm]	X [mm]	Y [mm]	V [mm]	W [mm]	Z [mm]	Stroke** [mm]
A55	55	71	67.5	25	50.5	27.5	32.5	15	∅ 24.9	1.5	52	2.35	∅ 47	200	28	12	0.5	54	108	3070

* For the position of the T-nuts when using our motor adapter plates, see pg. US-15ff Tab. 10
 ** Maximum stroke for a single-piece guiding rail. For longer strokes, see tab. 15

A55L with long slider

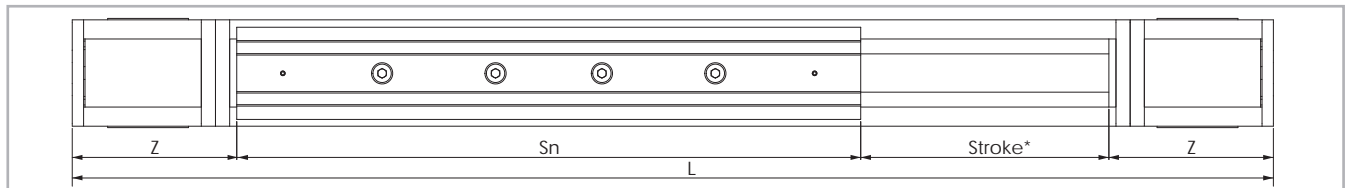

* The length of the safety stroke is provided on request according to the customer's specific requirements. Fig. 7

Type	S _{min} [mm]	S _{max} [mm]	Sn [mm]	Z [mm]	Stroke* [mm]
A055-L	310	500	$S_n = S_{min} + n \cdot 10$	108	2770

* Maximum stroke for a single-piece guiding rail and a maximum slider plate length S_{max}. For longer strokes, see tab. 15 Tab. 11

A55D with double slider

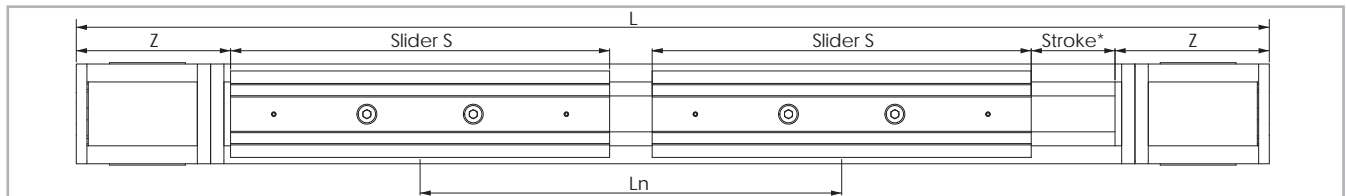

* The length of the safety stroke is provided on request according to the customer's specific requirements. Fig. 8

Type	S [mm]	L _{min} [mm]	L _{max} ** [mm]	Ln [mm]	Z [mm]	Stroke* [mm]
A55D	200	300	3070	$L_n = L_{min} + n \cdot 5$	108	2770

* Maximum stroke for a single-piece guiding rail and a minimum slider plate distance L_{min}. Tab. 12
 ** Maximum distance L_{max} between the centres of slider plates at a stroke of 0 mm. For longer strokes, see tab. 15

> Load ratings, moments and characteristic data

A55

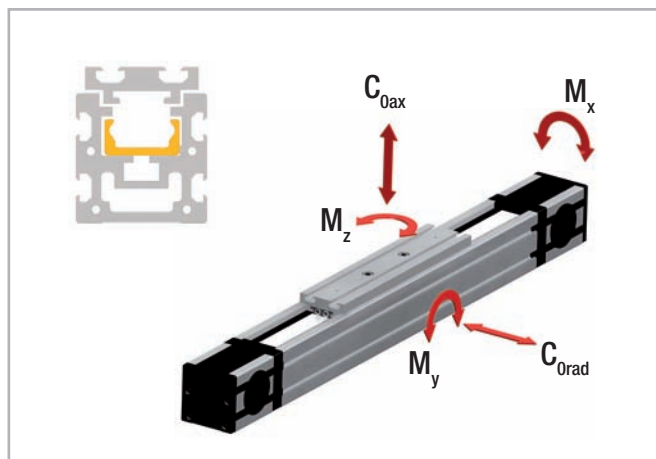

Fig. 9

Driving belt

The driving belt is manufactured from a friction resistant polyurethane and with steel cords for high tensile stress resistance.

Type	Type of belt	Belt width [mm]	Weight kg/m
A55	18RPP5	18	0.074

Tab. 13

Belt length (mm) = 2 x L - 182 Standard slider

Belt length (mm) = 2 x L - S_n + 18 Long slider

Belt length (mm) = 2 x L - L_n - 182 Double slider

Type	C [N]	C _{Orad} [N]	C _{0ax} [N]	M _x [Nm]	M _y [Nm]	M _z [Nm]
A55	4260	2175	750	11.5	21.7	54.4
A55-L	8520	4350	1500	23	82 to 225	239 to 652
A55-D	8520	4350	1500	23	225 to 2302	652 to 6677

For the calculation of the allowed moments, please observe pages SL-5ff

Tab. 14

Technical data	Type
	A55
Standard belt tension [N]	220
Moment at no load [Nm]	0.22
Max. traversing speed [m/s]	5
Max. acceleration [m/s ²]	15
Repeat accuracy [mm]	0.1
Linear accuracy [mm]	0.8
Compact Rail guiding rail	TLV28
Slider type	CS28 spec.
Moment of inertia I _y [cm ⁴]	34.6
Moment of inertia I _z [cm ⁴]	41.7
Pitch diameter of pulley [m]	0.04138
Moment of inertia of each pulley [gmm ²]	45633
Stroke per shaft revolution [mm]	130
Mass of slider [g]	475
Weight with zero stroke [g]	2897
Weight with 1 m stroke [g]	4505
Max. stroke [mm]	5500
Working temperature	from -20 °C to + 80 °C

Tab. 15

> A75

A75 system

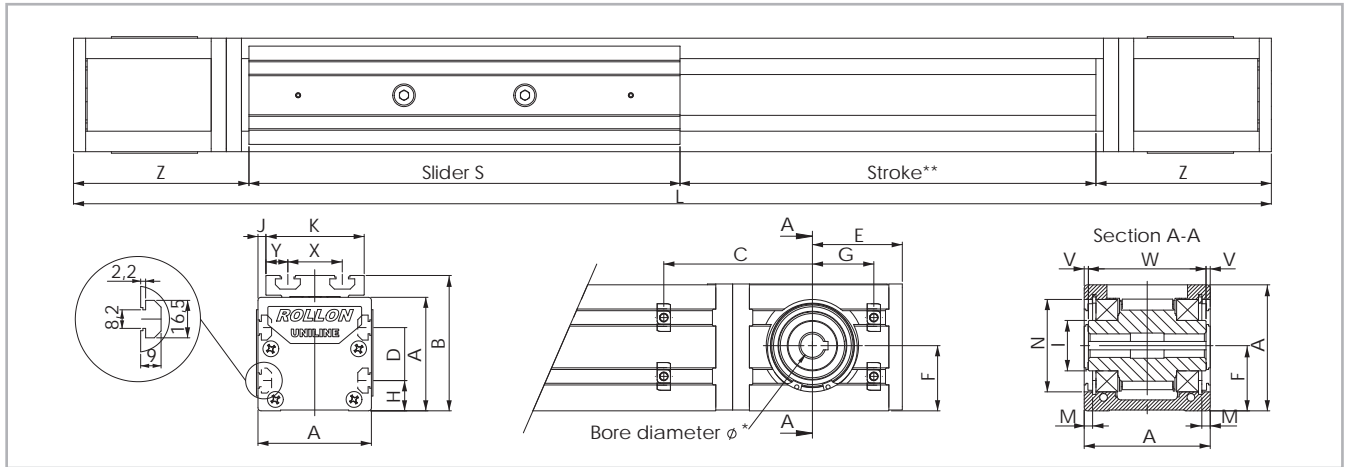

* For information on the motor connection bores, see ordering key. ** The length of the safety stroke is provided on request according to the customer's specific requirements. Fig. 10

Type	A [mm]	B [mm]	C* [mm]	D [mm]	E [mm]	F [mm]	G* [mm]	H [mm]	I [mm]	J [mm]	K [mm]	M [mm]	N [mm]	S [mm]	X [mm]	Y [mm]	V [mm]	W [mm]	Z [mm]	Stroke** [mm]
A75	75	90	71.5	35	53.5	38.8	34.5	20	∅ 29.5	5	65	4.85	∅ 55	285	36	14.5	2.3	70.4	116	3420

* For the position of the T-nuts when using our motor adapter plates, see pg. US-15ff
 ** Maximum stroke for a single-piece guiding rail. For longer strokes, see tab. 21 Tab. 16

A75L with long slider

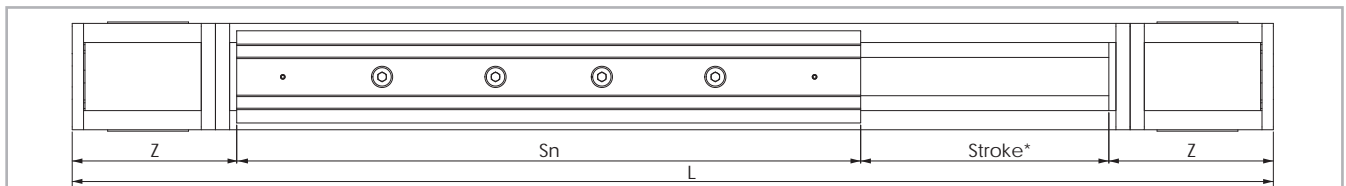

* The length of the safety stroke is provided on request according to the customer's specific requirements. Fig. 11

Type	S _{min} [mm]	S _{max} [mm]	Sn [mm]	Z [mm]	Stroke* [mm]
A75-L	440	700	$S_n = S_{min} + n \cdot 10$	116	3000

* Maximum stroke for a single-piece guiding rail and a maximum slider plate length S_{max}
 For longer strokes, see tab. 21 Tab. 17

A75D with double slider

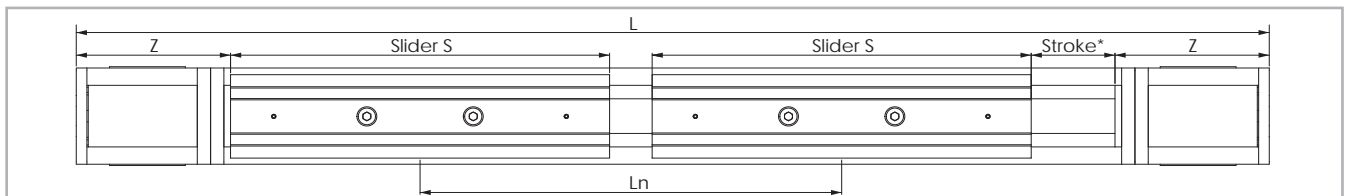

* The length of the safety stroke is provided on request according to the customer's specific requirements. Fig. 12

Type	S [mm]	L _{min} [mm]	L _{max} ** [mm]	Ln [mm]	Z [mm]	Stroke* [mm]
A75D	285	416	3416	$L_n = L_{min} + n \cdot 8$	116	3000

* Maximum stroke for a single-piece guiding rail and a minimum slider plate distance L_{min}
 ** Maximum distance L_{max} between the centres of slider plates at a stroke of 0 mm
 For longer strokes, see tab. 21 Tab. 18

> Load ratings, moments and characteristic data

A75

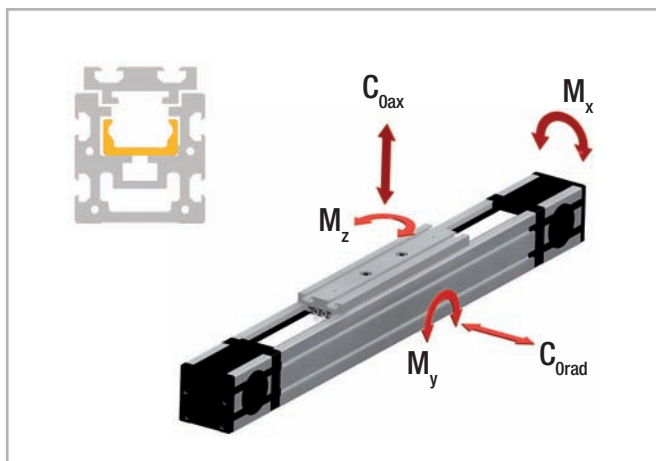

Fig. 13

Driving belt

The driving belt is manufactured from a friction resistant polyurethane and with steel cords for high tensile stress resistance.

Type	Type of belt	Belt width [mm]	Weight kg/m
A75	30RPP8	30	0.185

Tab. 19

Belt length (mm) = 2 x L - 213 Standard slider

Belt length (mm) = 2 x L - S_n+72 Long slider

Belt length (mm) = 2 x L - L_n - 213 Double slider

Type	C [N]	C _{0rad} [N]	C _{0ax} [N]	M _x [Nm]	M _y [Nm]	M _z [Nm]
A75	12280	5500	1855	43.6	81.5	209
A75-L	24560	11000	3710	87.2	287 to 770	852 to 2282
A75-D	24560	11000	3710	87.2	771 to 6336	2288 to 18788

For the calculation of the allowed moments, please observe pages SL-5ff

Tab. 20

Technical data	Type
	A75
Standard belt tension [N]	800
Moment at no load [Nm]	1.15
Max. traversing speed [m/s]	7
Max. acceleration [m/s ²]	15
Repeat accuracy [mm]	0.1
Linear accuracy [mm]	0.8
Compact Rail guiding rail	TLV43
Slider type	CS43 spec.
Moment of inertia I _y [cm ⁴]	127
Moment of inertia I _z [cm ⁴]	172
Pitch diameter of pulley [m]	0.05093
Moment of inertia of each pulley [gmm ²]	139969
Stroke per shaft revolution [mm]	160
Mass of slider [g]	1242
Weight with zero stroke [g]	6729
Weight with 1 m stroke [g]	9751
Max. stroke [mm]	7500
Working temperature	from -20 °C to + 80 °C

Tab. 21

> A100

A100 system

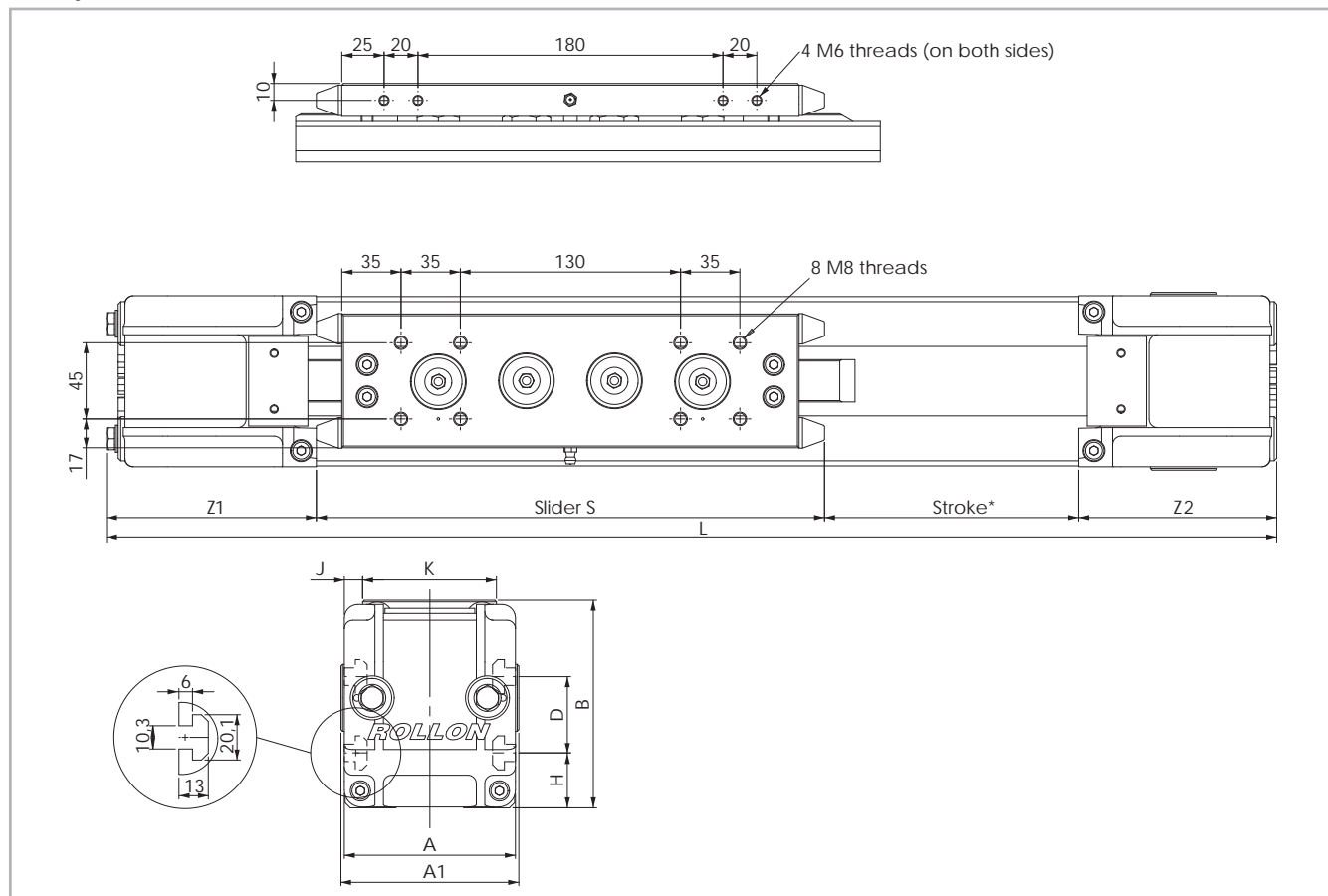

* The length of the safety stroke is provided on request according to the customer's specific requirements.

Fig. 14

Type	A [mm]	A ₁ [mm]	B [mm]	D [mm]	H [mm]	J [mm]	K [mm]	S [mm]	Z ₁ [mm]	Z ₂ [mm]	Stroke* [mm]
A100	101	105	122.5	45	32.5	10.5	79	300	123	117	3420

* Maximum stroke for a single-piece guiding rail. For longer strokes, see tab. 27

Tab. 22

A100L with long slider

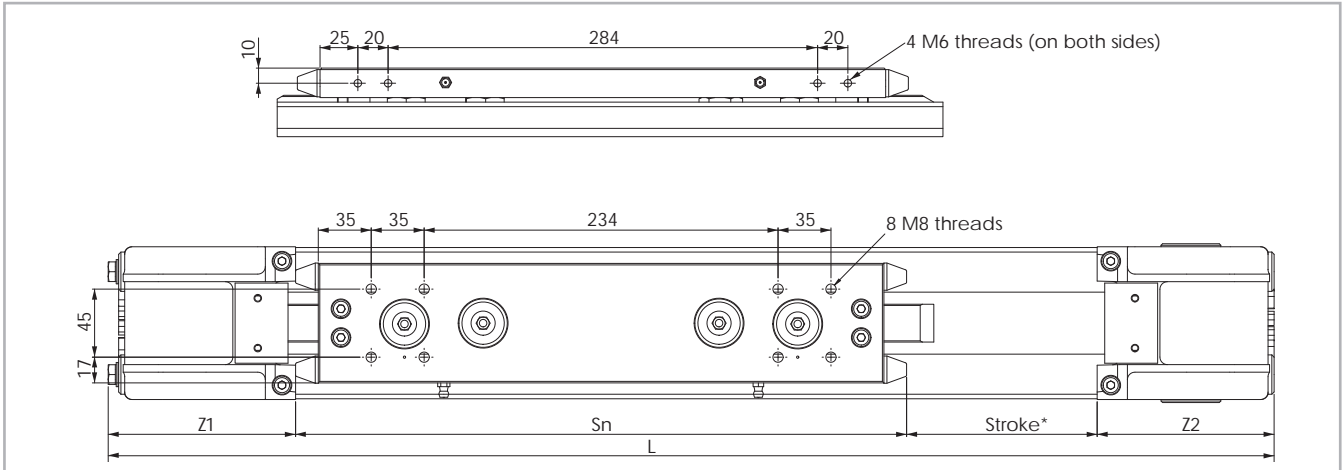

* The length of the safety stroke is provided on request according to the customer's specific requirements.

Fig. 15

Type	S _{min} [mm]	S _{max} [mm]	Sn [mm]	Z ₁ [mm]	Z ₂ [mm]	Stroke* [mm]
A100L	404	404	$S_n = S_{min} = S_{max}$	123	117	3316

* Maximum stroke for a single-piece guiding rail and a maximum slider plate length S_{max}.
For longer strokes, see tab. 27

Tab. 23

A100D with double slider

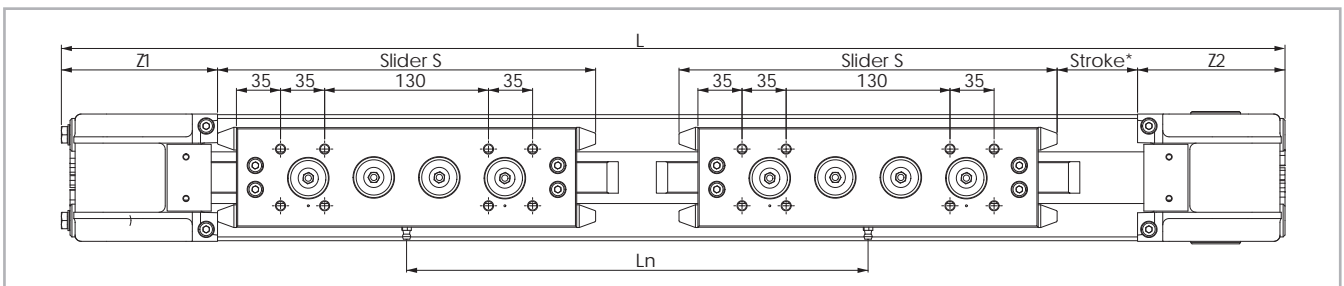

* The length of the safety stroke is provided on request according to the customer's specific requirements.

Fig. 16

Type	S [mm]	L _{min} [mm]	L _{max} ** [mm]	Ln [mm]	Z ₁ [mm]	Z ₂ [mm]	Stroke* [mm]
A100D	300	396	3396	$L_n = L_{min} + n \cdot 50$	123	117	3024

* Maximum stroke for a single-piece guiding rail and a minimum slider plate distance L_{min}.

** Maximum distance L_{max} between the centres of slider plates at a stroke of 0 mm

For longer strokes, see tab. 27

Tab. 24

> Load ratings, moments and characteristic data

A100

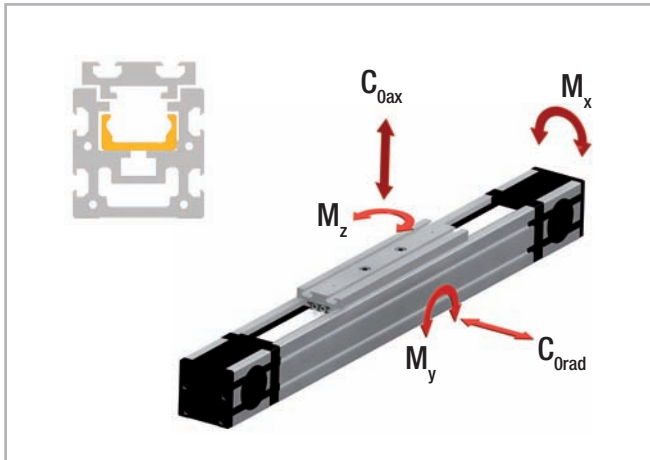

Fig. 17

Driving belt

The driving belt is manufactured from a friction resistant polyurethane and with steel cords for high tensile stress resistance.

Type	Type of belt	Belt width [mm]	Weight kg/m
A100	36AT10	36	0.220

Tab. 25

Belt length (mm) = 2 x L - 197 Standard slider

Belt length (mm) = 2 x L + 301 Long slider

Belt length (mm) = 2 x L - L_n - 197 Double slider

Type	C [N]	C _{0rad} [N]	C _{0ax} [N]	M _x [Nm]	M _y [Nm]	M _z [Nm]
A100	30750	12500	7200	250	250	600
A100-L	30750	12500	7200	250	500	1200
A100-D	61500	25000	14400	500	2851 to 24451	4950 to 42450

For the calculation of the allowed moments, please observe pages SL-5ff

Tab. 26

Technical data	Type
	A100
Standard belt tension [N]	1000
Moment at no load [Nm]	2.3
Max. traversing speed [m/s]	9
Max. acceleration [m/s ²]	20
Repeat accuracy [mm]	0.1
Linear accuracy [mm]	0.8
Compact Rail guiding rail	TLV63
Slider type	CS63 spec.
Moment of inertia I _y [cm ⁴]	500
Moment of inertia I _z [cm ⁴]	400
Pitch diameter of pulley [m]	0.06048
Moment of inertia of each pulley [gmm ²]	330000
Stroke per shaft revolution [mm]	190
Mass of slider [g]	4200
Weight with zero stroke [g]	12700
Weight with 1 m stroke [g]	15950
Max. stroke [mm]	5600
Working temperature	from -20 °C to + 80 °C

Tab. 27

A100 motor connection – model A

Motor connection via key

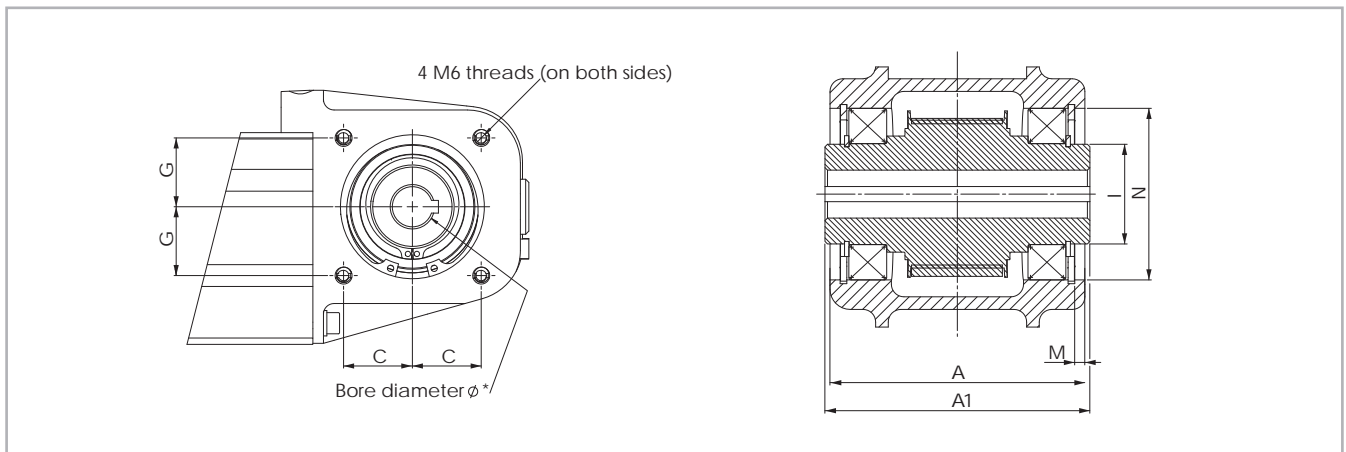

* For information on the motor connection bores, see ordering key
 ** For information on the motor drive shaft, see chapter Accessories, pg. US-15

Fig. 18

A100 motor connection – model B

Motor connection via Shrink Disk

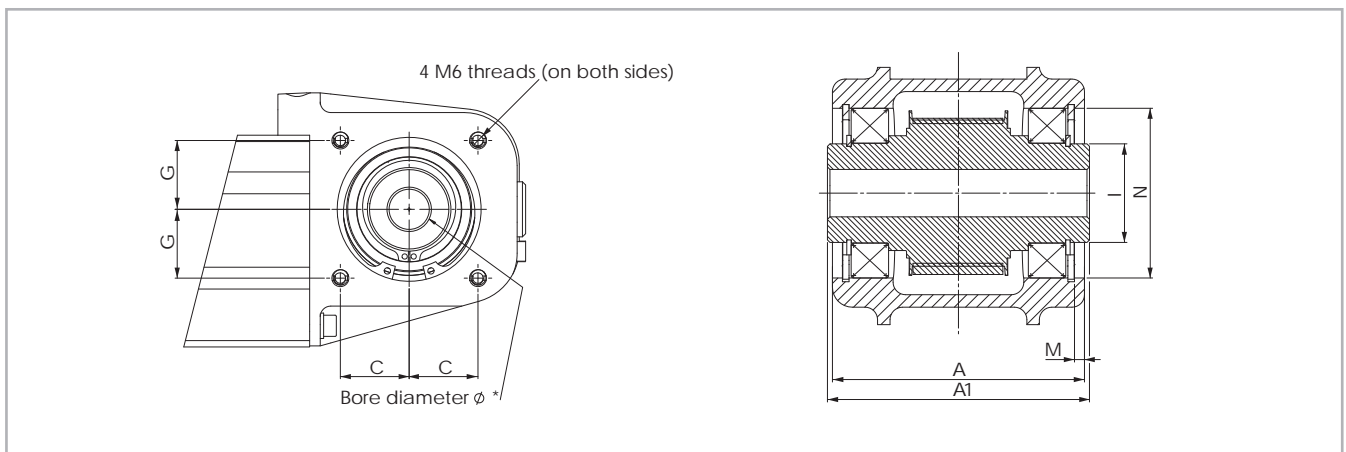

* See chapter Accessories, pg. US-15

Fig. 19

Type	A [mm]	A ₁ [mm]	C [mm]	G [mm]	I [mm]	M [mm]	N [mm]
A100	101	105	32.5	32.5	Ø 39,5	4	Ø 68

Tab. 28

> Lubrication

The raceways of the guide rails in the Uniline linear axes are prelubricated. To achieve the calculated service life, a lubrication film must always be present between the raceway and the roller. The lubrication film also provides anticorrosion protection to the ground raceways. An approximate value for the lubrication period is every 100 km or every six months. The recommended lubricant is a lithium-based roller bearing grease of medium consistency.

Lubrication of the raceways

Proper lubrication under normal conditions:

- reduces friction
- reduces wear
- reduces stress on the contact faces
- reduces running noise

Lubricants	Thickeners	Temperature range [°C]	Dynamic viscosity [mPas]
Roller bearing grease	Lithium soap	-30 to +170	<4500

Tab. 29

Relubrication of the guide rails

These types of rails have a lubricating conduit on the side of the slider plate (type A100 is equipped with lubricating nipple) through which the lubricant can be applied directly to the raceways. Lubrication can be done in one of two ways:

1. Relubrication using a grease gun:

This is done by inserting the tip of the grease gun into the conduit at the slider plate and injecting the grease inside (see fig. 20). Please note that the grease has to fill the whole conduit in order to lubricate the rail properly; for this reason sufficient grease must be used.

2. Automatic lubrication system:

To connect the unit to an automatic greasing system, use a proper adapter/connector* that attaches to the threaded hole on the side of the trolley.

The advantage of this solution is the possibility of rail re-lubrication without machine downtime.

*(Any adapter that may be necessary must be manufactured on site)

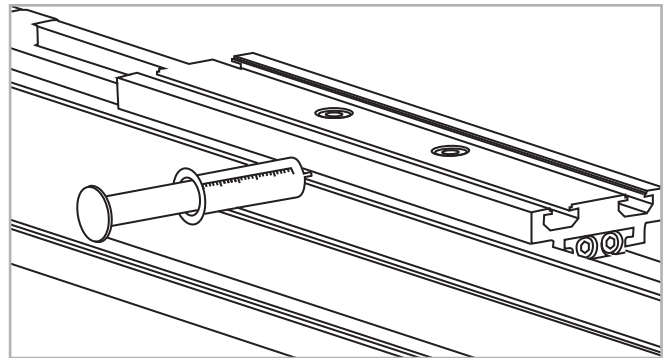

Fig. 20

Cleaning the guide rails

It is always recommended to clean the slider rail prior to any relubrication, in order to remove grease residues. This can be done while performing maintenance work or during a scheduled machine stop.

1. Unscrew the safety screws C (on top of the slider plate) from the belt tensioning device A (see fig. 21).
2. Also completely unscrew the belt tensioning screws B and remove the belt tensioning devices A from their housings.
3. Lift the toothed belt until the guide rails can be seen.
Important: Ensure that the side seal is not damaged.
4. Clean the rail raceways with a clean and dry cloth. Ensure that all grease and dirt residues from previous work processes are removed.
To ensure that the rails are cleaned over their entire length, the slider plate should be moved once over its entire length.
5. Apply a sufficient amount of grease to the raceways.

6. Re-insert the belt tensioning devices A into their housings and mount the belt tensioning screws B. Re-adjust the belt tension (see pg. US-63).

7. Fasten the safety screws C.

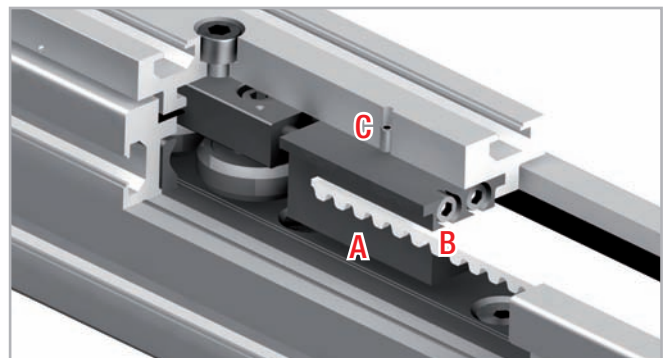

Fig. 21

> Accessories

Adapter plates

Standard motor adapter plates AC2

Mounting plates for the most common motors or gearboxes. The connection bores for the motors or gearboxes must be made on site. All plates are delivered with M6 x 10 screws to DIN 912 and T-nuts for mounting on the linear units.

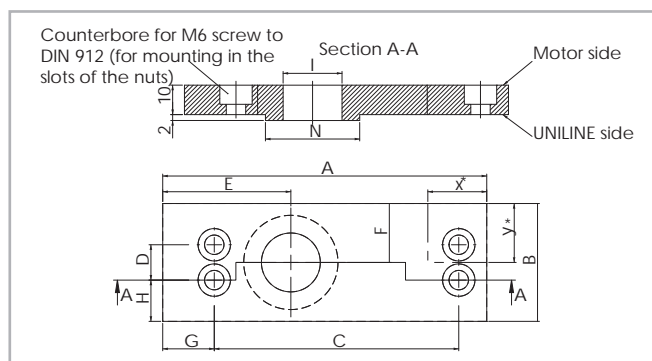

Fig. 22

Size	A [mm]	B [mm]	C [mm]	D [mm]	E [mm]	F [mm]	G [mm]	H [mm]	I [mm]	N [mm]
40	110	40	83	12	43.5	20	17.5	14	∅ 20	∅ 32
55	126	55	100	25	50.5	27.5	18	15	∅ 30	∅ 47
75	135	70	106	35	53.5	35	19	17.5	∅ 35	∅ 55

Tab. 30

NEMA plates AC1-P

Mounting plates for NEMA motors or gearboxes. These plates are delivered ready-to-mount on the linear axes. All plates are delivered with M6 x 10 screws to DIN 912 and T-nuts for mounting on the linear units.

Size	NEMA Motors / Gearboxes
40	NEMA 23
55	NEMA 34
75	NEMA 42

Tab. 31

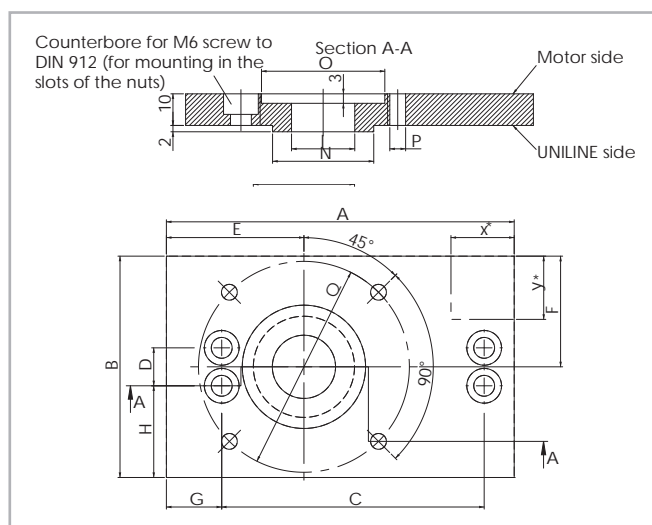

Fig. 23

Size	A [mm]	B [mm]	C [mm]	D [mm]	E [mm]	F [mm]	G [mm]	H [mm]	I [mm]	N [mm]	O [mm]	P [mm]	Q [mm]
40	110	70	83	12	43.5	35	17.5	29	20	∅ 32	∅ 39	∅ 5	∅ 66.7
55	126	100	100	25	50.5	50	18	37.5	30	∅ 47	∅ 74	∅ 5.5	∅ 98.4
75	135	120	106	35	53.5	60	19	42.5	35	∅ 55	∅ 57	∅ 7.1	∅ 125.7

Tab. 32

Synchronous use of linear axes in pairs

If two axes are to be used in parallel using a connecting shaft, please specify when ordering, to ensure that the key slots of the pulleys are synchronized.

Fixing brackets APF-2

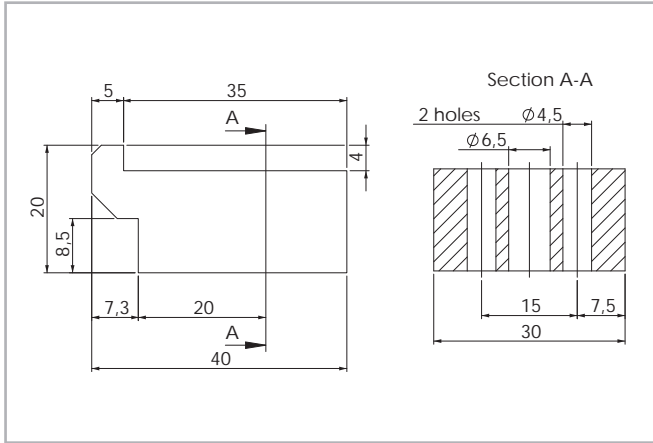

Fig. 24

Fixing clamp (for all sizes except A100) for simple mounting of a linear axis on a mounting surface or for connecting two units with or without a connection plate (see pg. US-68).

A spacer* may be necessary.

*(Any spacer that may be necessary must be manufactured on site)

T-nut

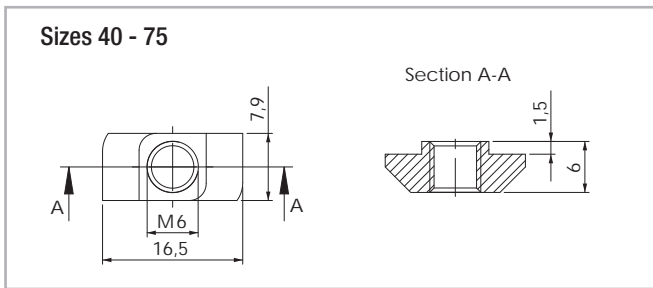
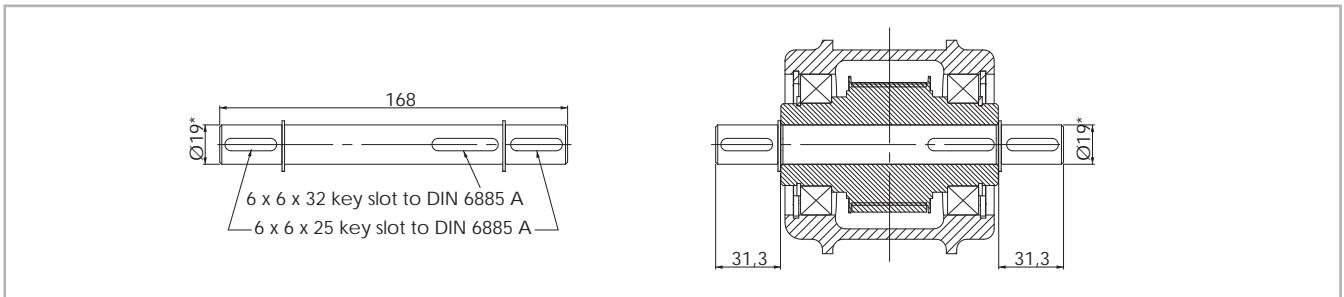

Fig. 25

The maximum tightening torque is 10 Nm.

A100 double AS

For type A100 with motor connection A only.



* Also available with a 20 mm diameter shaft

Fig. 26

A100 conical fitting device AC-10MA01

For type A100 with motor connection B only.

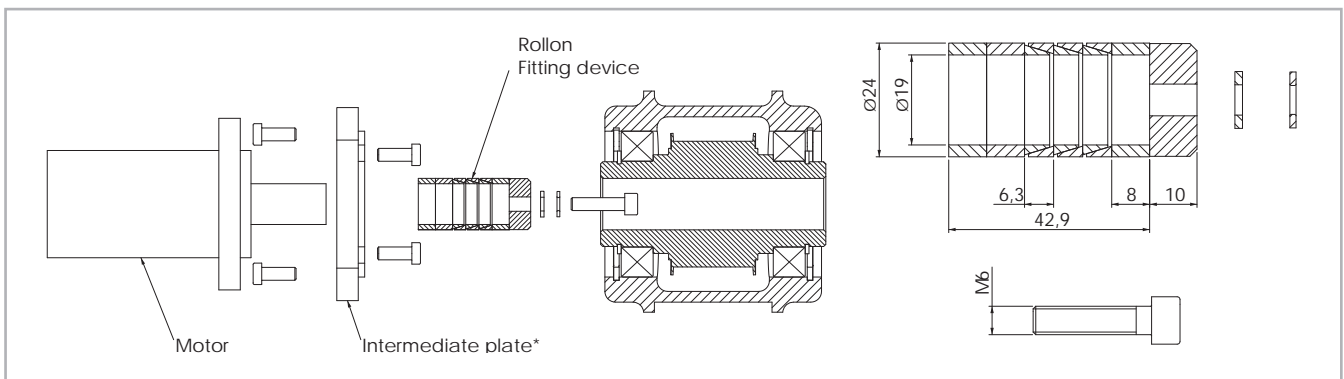

* Any intermediate plate that may be necessary must be manufactured on site.

Fig. 27

The maximum transferrable torque is 63 Nm.

Assembly kits

T-connection plate APC-1

T-connection plate allows two units to be mounted perpendicular to each other (see pg. US-65). The plate will not interfere with the strokes of either unit. All plates are delivered with M6 x 10 screws to DIN 912 and T-nuts for mounting on the linear units.

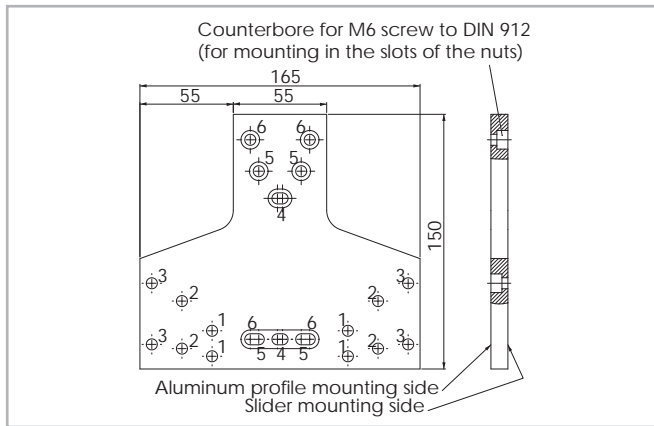

Fig. 28

Angle connection plate APC-2

allows the right angle mounting of two units. The trolley of one unit can be mounted to the side of the other (see pg. US-66). The plate will not interfere with the strokes of either unit. All plates are delivered with M6 x 10 screws to DIN 912 and T-nuts for mounting to the linear units.

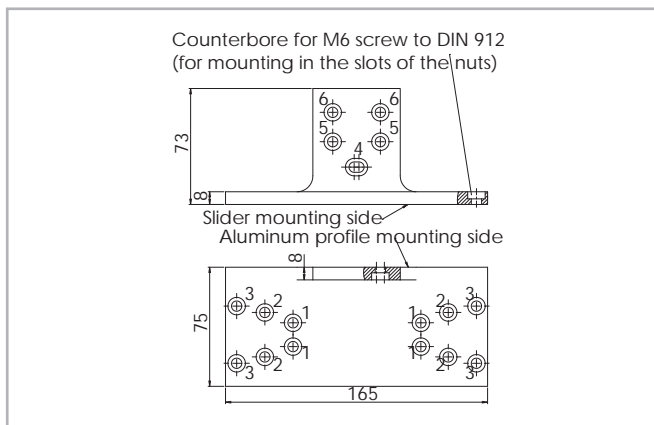

Fig. 29

X connection plate APC-3

X connection plate for mounting two sliders perpendicular to each other (see pg. US-67). The plate will not interfere with the strokes of either unit. All plates are delivered with M6 x 10 screws to DIN 912 and T-nuts for mounting on the linear units.

Size	Fixing holes for slider 1	Fixing holes for slider 2
40	Holes 1	Holes 4
55	Holes 2	Holes 5
75	Holes 3	Holes 6

Tab. 35

Size	Fixing holes for the slider	Fixing holes for the profile
40	Holes 1	Holes 4
55	Holes 2	Holes 5
75	Holes 3	Holes 6

Tab. 33

Size	Fixing holes for the slider	Fixing holes for the profile
40	Holes 1	Holes 4
55	Holes 2	Holes 5
75	Holes 3	Holes 6

Tab. 34

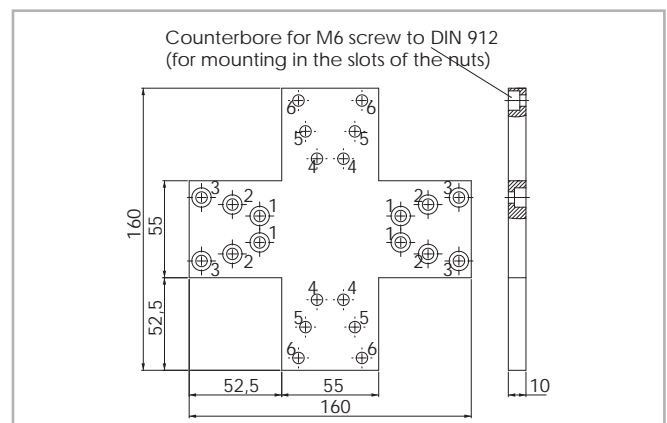

Fig. 30

Ordering key 

> Identification code for Uniline linear unit

U	A	07	1A	1190	1A	D 500	L 350	
		04=40						
		05=55						
		07=75						Indices of long slider plate <i>see pg. US-4 - US-6 - US-8 - US-10</i>
		10=100						Indices of double slider plate, <i>distance of the centers of slider plates</i> <i>see pg. US-4 - US-6 - US-8 - US-10</i>
								Profile/Rail code
								L= Total length of the unit
								Driving head code
								Size <i>see pg. US-4 - US-6 - US-8 - US-10</i>
								Type
								Uniline prefix

Ordering example: UA 07 1A 1190 1A D 500 L 350

In order to create identification codes for Actuator Line, you can visit: <http://configureactuator.rollon.com>

> Accessories

Standard motor adapter plate

A	07	AC2	
	04=40		
	05=55		
	07=75		Standard motor adapter plates <i>see pg. US-15</i>
	10=100		
	Size		<i>see pg. US-15</i>
Type (except A100)			

Ordering example: A07-AC2

NEMA motor adapter plates

A	07	AC1	
	04=40		
	05=55		
	07=75		NEMA motor adapter plates <i>see pg. US-15</i>
	10=100		
	Size		<i>see pg. US-15</i>
Type (except A100)			

Ordering example: A07-AC1

- T-connection plate** Order code: APC-1 (for all sizes except A100), s. pg. US-17
- Angle connection plate** Order code: APC-2 (for all sizes except A100), s. pg. US-17
- X connection plate** Order code: APC-3 (for all sizes except A100), s. pg. US-17
- Fixing clamp** Order code: APF-2 (for all sizes except A100), s. pg. US-16

Motor connection bores

Hole [Ø]	Size				Head code
	40	55	75	100	
Metric [mm] with slot for key	10G8 / 3js9	12G8 / 4js9	14G8 / 5js9	19G8 / 6js9	1A
		10G8 / 3js9	16G8 / 5js9	20G8 / 6js9	2A
		14G8 / 5js9	19G8 / 6js9		3A
		16G8 / 5js9			4A
Metric [mm] for compression coupling			18	24	1B
			24		2B
Inch [in] with slot for key	3/8 / 1/8	1/2 / 1/8	5/8 / 3/16		1P
		3/8 / 1/8			2P
		5/8 / 3/16			3P

The highlighted connection bores are standard connections

Tab. 36

Metric: key seat for keys to DIN 6885 form A

Inch: key seat for keys to BS 46 Part 1: 1958

Uniline C series



> Uniline C series description

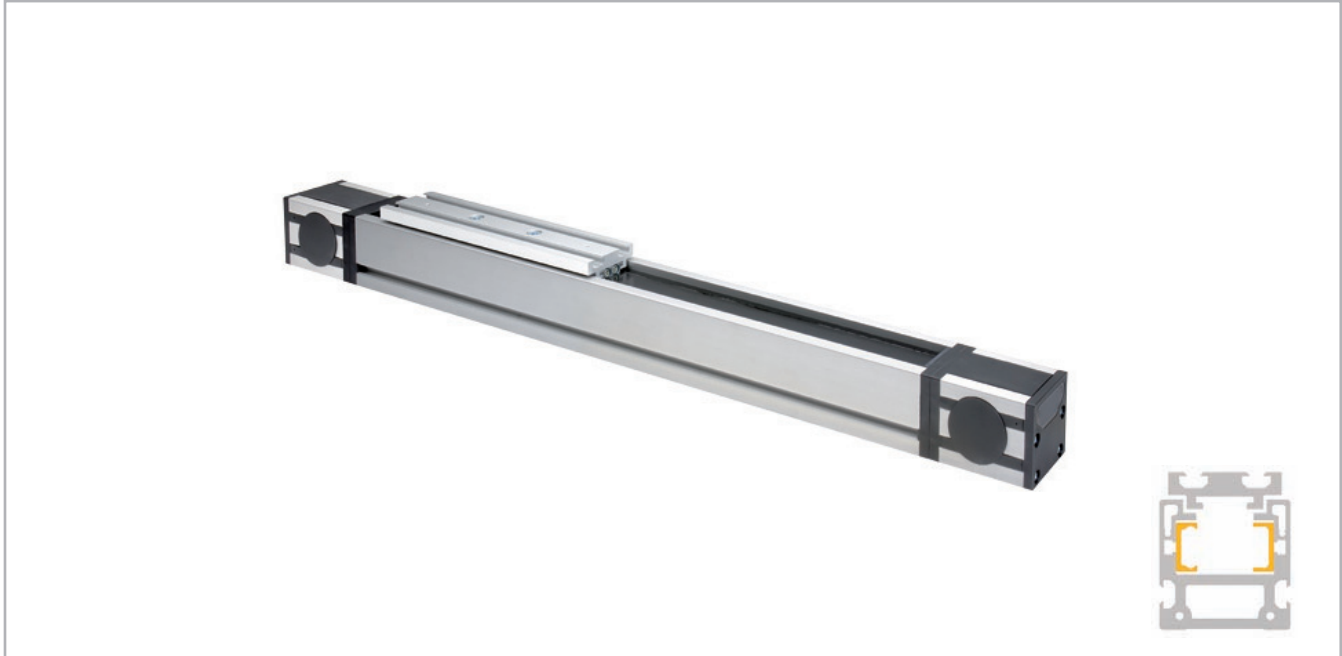

Fig. 31

Uniline is a family of ready-to-install linear actuators. They consist of internal Compact Rail roller sliders and steel-reinforced polyurethane belts in a rigid aluminum profile. Longitudinal seals enclose the system. This arrangement provides the best protection for the actuator from soiling and damage. In the C series, the fixed bearing rail (T-rail) and the compensating bearing rail (U-rail) are mounted in the aluminum profile vertically. Versions with long (L) or double (D) sliders in one axis are possible.

The most important characteristics:

- Compact design
- Protected internal linear guides
- High traversing speeds
- Grease-free operation possible (depending on the application. For further information, please contact our Application Engineering department)
- High versatility
- Long strokes
- Versions with long or multiple sliders available in one linear axis

Preferred areas of application:

- Handling and automation
- Multi-axis gantries
- Packaging machines
- Cutting machines
- Displaceable panels
- Painting installations
- Welding robots
- Special machines

Technical data:

- Available sizes [mm]:
Type C: 55, 75
- Length and stroke tolerances:
For strokes <1 m: +0 mm to +10 mm (+0 in to 0.4 in)
For strokes >1 m: +0 mm to +15 mm (+0 in to 0.59 in)

> The components

Extruded profile

The anodized 6060 aluminum alloy extrusion used for the profile of the Rollon Uniline C series linear units were designed and manufactured by industry experts to optimize weight while maintaining mechanical strength. (see physical-chemical characteristics below). The dimensional tolerances comply with EN 755-9 standard.

Driving belt

The Rollon Uniline C series linear units use steel reinforced polyurethane drive belts with RPP pitch and parabolic profiles. This belt is ideal due to its high load transmission characteristics, compact size and low noise. Used in conjunction with a backlash-free pulley, smooth alternating motion can

be achieved. Optimization of the maximum belt width/body dimension ratio enables the following performance characteristics to be achieved:

- High speed
- Low noise
- Low wear

Carriage

The carriage of the Rollon Uniline C series linear units are made entirely of anodized aluminum. Each carriage has mounting T-slots for the connection to the moving element. Rollon offers multiple carriages to accommodate a vast array of applications.

General data about aluminum used: AL 6060

Chemical composition [%]

Al	Mg	Si	Fe	Mn	Zn	Cu	Impurites
Remainder	0.35-0.60	0.30-0.60	0.30	0.10	0.10	0.10	0.05-0.15

Tab. 37

Physical characteristics

Density	Coeff. of elasticity	Coeff. of thermal expansion (20°-100°C)	Thermal conductivity (20°C)	Specific heat (0°-100°C)	Resistivity	Melting point
$\frac{\text{kg}}{\text{dm}^3}$	$\frac{\text{kN}}{\text{mm}^2}$	$\frac{10^{-6}}{\text{K}}$	$\frac{\text{W}}{\text{m} \cdot \text{K}}$	$\frac{\text{J}}{\text{kg} \cdot \text{K}}$	$\Omega \cdot \text{m} \cdot 10^{-9}$	°C
2.7	69	23	200	880-900	33	600-655

Tab. 38

Mechanical characteristics

Rm	Rp (02)	A	HB
$\frac{\text{N}}{\text{mm}^2}$	$\frac{\text{N}}{\text{mm}^2}$	%	—
205	165	10	60-80

Tab. 39

> C55

C55 system

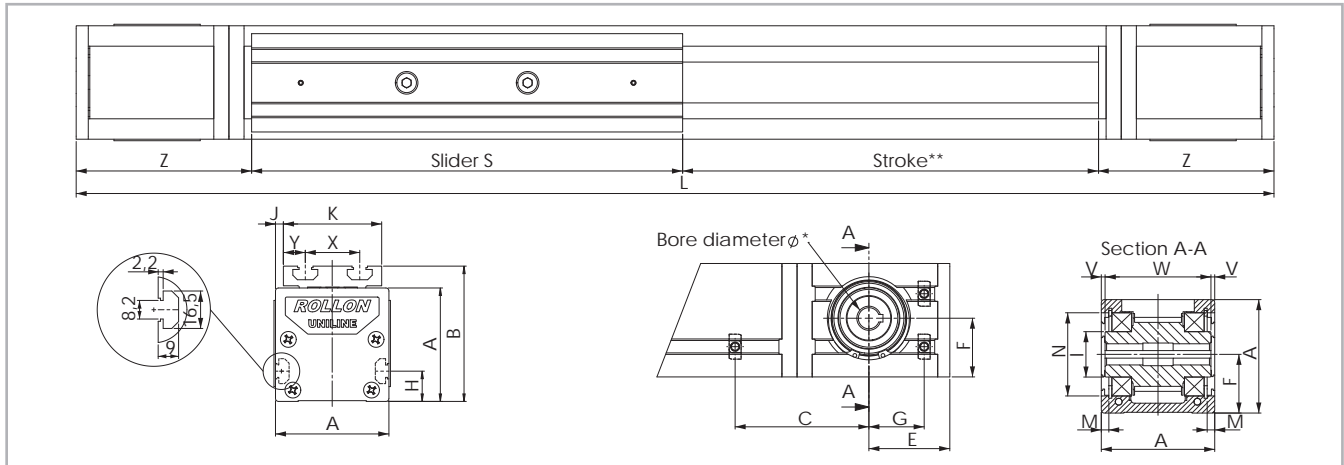

* For information on the motor connection bores, see ordering key. ** The length of the safety stroke is provided on request according to the customer's specific requirements. Fig. 32

Type	A [mm]	B [mm]	C* [mm]	E [mm]	F [mm]	G* [mm]	H [mm]	I [mm]	J [mm]	K [mm]	M [mm]	N [mm]	S [mm]	X [mm]	Y [mm]	V [mm]	W [mm]	Z [mm]	Stroke** [mm]
C55	55	71	67.5	50.5	27.5	32.5	15	∅ 24.9	1.5	52	2.35	∅ 47	200	28	12	0.5	54	108	1850

* For the position of the T-nuts when using our motor adapter plates, see pg. US-27ff
 ** Maximum stroke for a single-piece guiding rail. For longer strokes, see tab. 45 Tab. 40

C55L with long slider

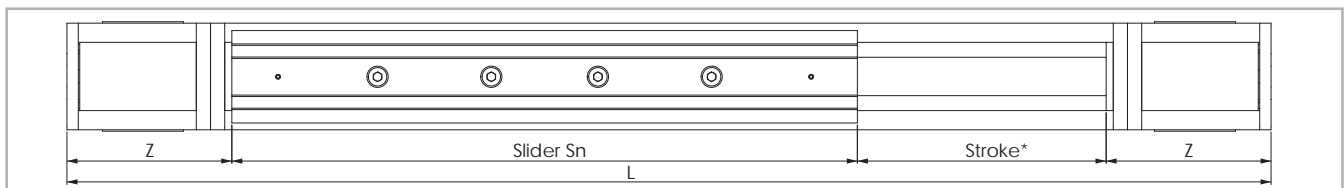

* The length of the safety stroke is provided on request according to the customer's specific requirements. Fig. 33

Type	S _{min} [mm]	S _{max} [mm]	Sn [mm]	Z [mm]	Stroke* [mm]
C55L	310	500	$S_n = S_{min} + n \cdot 10$	108	1550

* Maximum stroke for a single-piece guiding rail and a maximum slider plate length S_{max}
 For longer strokes, see tab. 45 Tab. 41

C55D with double slider

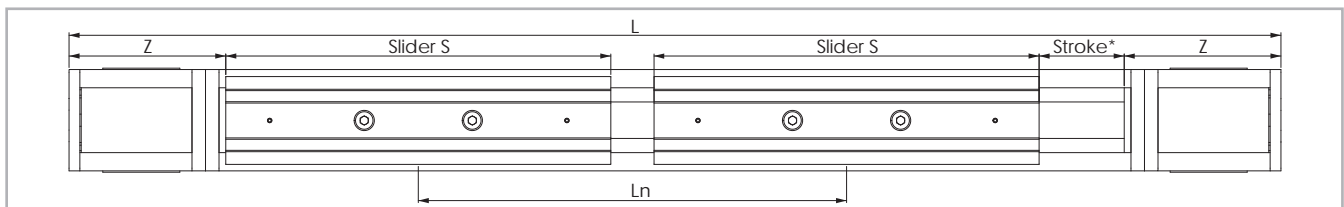

* The length of the safety stroke is provided on request according to the customer's specific requirements. Fig. 34

Type	S [mm]	L _{min} [mm]	L _{max} ** [mm]	Ln [mm]	Z [mm]	Stroke* [mm]
C55D	200	300	1850	$L_n = L_{min} + n \cdot 5$	108	1570

* Maximum stroke for a single-piece guiding rail and a minimum slider plate distance L_{min}
 ** Maximum distance L_{max} between the centres of slider plates at a stroke of 0 mm
 For longer strokes, see tab. 45 Tab. 42

> Load ratings, moments and characteristic data

C55

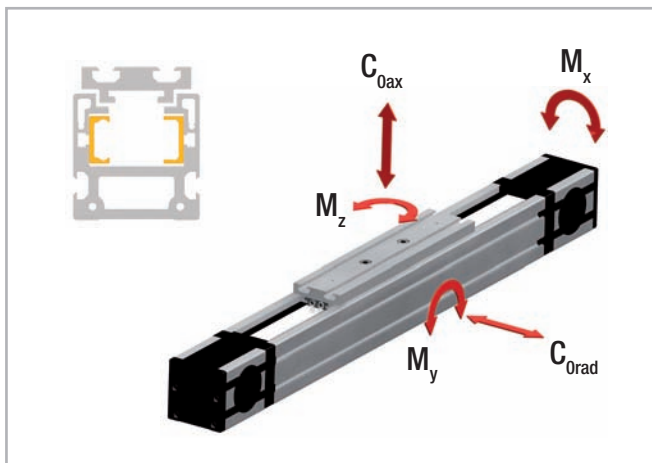

Fig. 35

Driving belt

The driving belt is manufactured from a friction resistant polyurethane and with steel cords for high tensile stress resistance.

Type	Type of belt	Belt width [mm]	Weight kg/m
C55	18RPP5	18	0.074

Tab. 43

Belt length (mm) = 2 x L - 182 Standard slider

Belt length (mm) = 2 x L - S_n+18 Long slider

Belt length (mm) = 2 x L - L_n - 182 Double slider

Type	C [N]	C _{0rad} [N]	C _{0ax} [N]	M _x [Nm]	M _y [Nm]	M _z [Nm]
C55	560	300	1640	18.5	65.6	11.7
C55-L	1120	600	3280	37	213 to 525	39 to 96
C55-D	1120	600	3280	37	492 to 3034	90 to 555

For the calculation of the allowed moments, please observe pages SL-5ff

Tab. 44

Technical data	Type
	C55
Standard belt tension [N]	220
Moment at no load [Nm]	0.3
Max. traversing speed [m/s]	3
Max. acceleration [m/s ²]	10
Repeat accuracy [mm]	0.1
Linear accuracy [mm]	0.8
Compact Rail guiding rail	TLV18 / ULV18
Slider type	2 CS18 spec.
Moment of inertia I _y [cm ⁴]	34.4
Moment of inertia I _z [cm ⁴]	45.5
Pitch diameter of pulley [m]	0.04138
Moment of inertia of each pulley [gmm ²]	45633
Stroke per shaft revolution [mm]	130
Mass of slider [g]	549
Weight with zero stroke [g]	2971
Weight with 1 m stroke [g]	4605
Max. stroke [mm]	5500
Working temperature	from -20 °C to + 80 °C

Tab. 45

> C75

C75 system

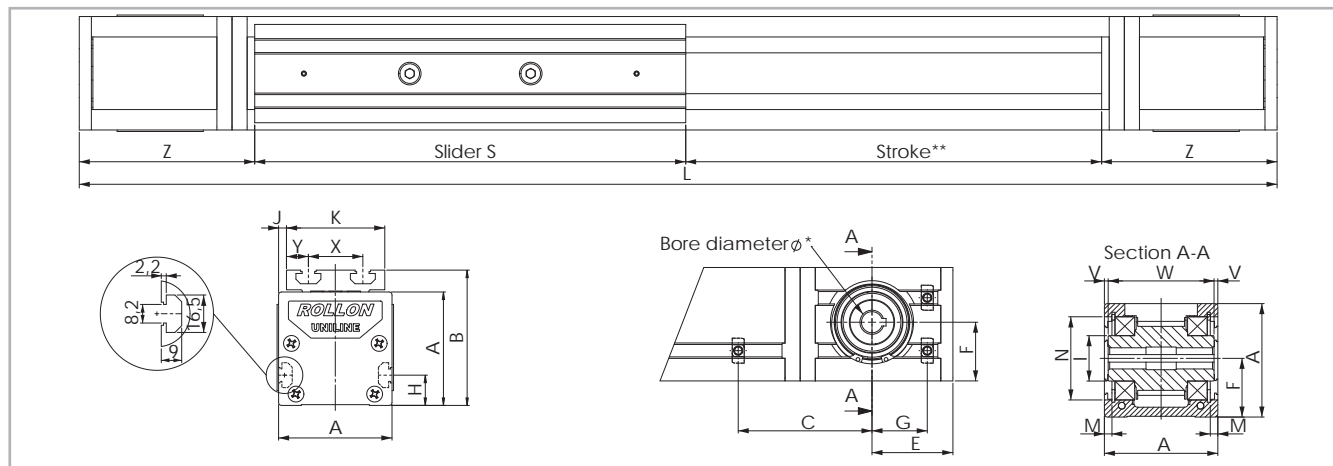

* For information on the motor connection bores, see ordering key. ** The length of the safety stroke is provided on request according to the customer's specific requirements. Fig. 36

Type	A [mm]	B [mm]	C* [mm]	E [mm]	F [mm]	G* [mm]	H [mm]	I [mm]	J [mm]	K [mm]	M [mm]	N [mm]	S [mm]	X [mm]	Y [mm]	V [mm]	W [mm]	Z [mm]	Stroke** [mm]
C75	75	90	71.5	53.5	38.8	34.5	20	∅ 29.5	5	65	4.85	∅ 55	285	36	14.5	2.3	70.4	116	3000

* For the position of the T-nuts when using our motor adapter plates, see pg. US-27ff
 ** Maximum stroke for a single-piece guiding rail. For longer strokes, see tab. 51 Tab. 46

C75L with long slider

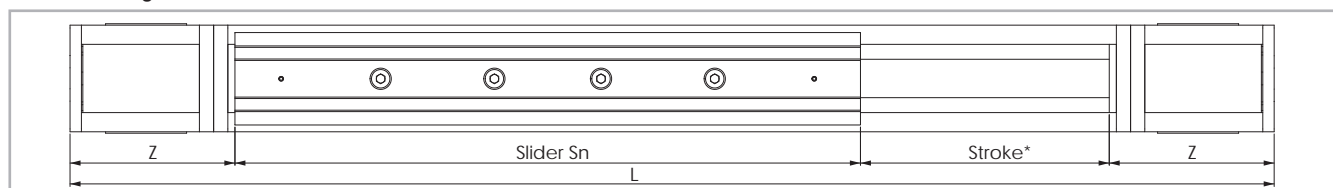

* The length of the safety stroke is provided on request according to the customer's specific requirements. Fig. 37

Type	S _{min} [mm]	S _{max} [mm]	Sn [mm]	Z [mm]	Stroke* [mm]
C75L	440	700	$S_n = S_{min} + n \cdot 10$	116	2610

* Maximum stroke for a single-piece guiding rail and a maximum slider plate length S_{max}
 For longer strokes, see tab. 51 Tab. 47

C75D with double slider

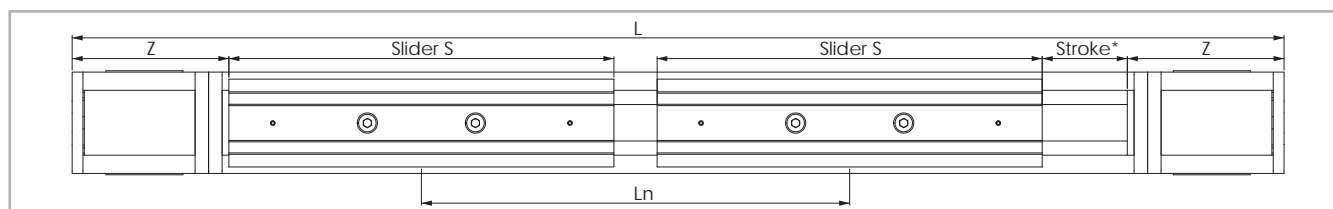

* The length of the safety stroke is provided on request according to the customer's specific requirements. Fig. 38

Type	S [mm]	L _{min} [mm]	L _{max} ** [mm]	Ln [mm]	Z [mm]	Stroke* [mm]
C75D	285	416	3024	$L_n = L_{min} + n \cdot 8$	116	2610

* Maximum stroke for a single-piece guiding rail and a minimum slider plate distance L_{min}
 ** Maximum distance L_{max} between the centres of slider plates at a stroke of 0 mm
 For longer strokes, see tab. 51 Tab. 48

> Load ratings, moments and characteristic data

C75

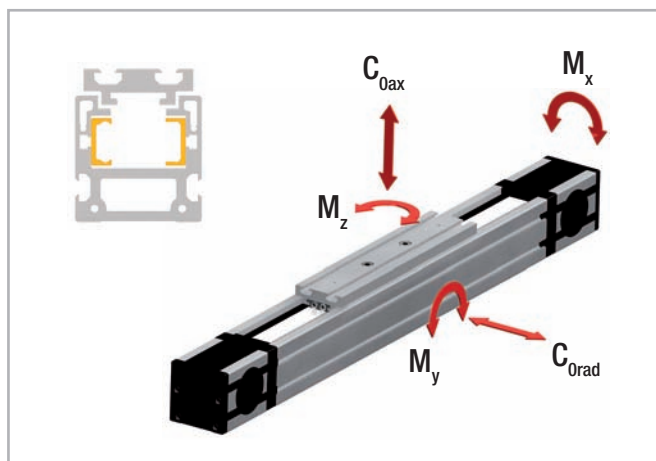

Fig. 39

Driving belt

The driving belt is manufactured from a friction resistant polyurethane and with steel cords for high tensile stress resistance.

Type	Type of belt	Belt width [mm]	Weight kg/m
C75	30RPP8	30	0.185

Tab. 49

Belt length (mm) = 2 x L - 213 Standard slider

Belt length (mm) = 2 x L - S_n+72 Long slider

Belt length (mm) = 2 x L - L_n - 213 Double slider

Type	C [N]	C _{0rad} [N]	C _{0ax} [N]	M _x [Nm]	M _y [Nm]	M _z [Nm]
C75	1470	750	4350	85.2	217	36.1
C75-L	2940	1500	8700	170.4	674 to 1805	116 to 311
C75-D	2940	1500	8700	170.4	1809 to 13154	312 to 2268

For the calculation of the allowed moments, please observe pages SL-5ff

Tab. 50

Technical data	Type
	C75
Standard belt tension [N]	800
Moment at no load [Nm]	1.3
Max. traversing speed [m/s]	5
Max. acceleration [m/s ²]	15
Repeat accuracy [mm]	0.1
Linear accuracy [mm]	0.8
Compact Rail guiding rail	TLV28 / ULV28
Slider type	2 CS28 spec.
Moment of inertia I _y [cm ⁴]	108
Moment of inertia I _z [cm ⁴]	155
Pitch diameter of pulley [m]	0.05093
Moment of inertia of each pulley [gmm ²]	139969
Stroke per shaft revolution [mm]	160
Mass of slider [g]	1666
Weight with zero stroke [g]	6853
Weight with 1 m stroke [g]	9151
Max. stroke [mm]	7500
Working temperature	from -20 °C to + 80 °C

Tab. 51

> Lubrication

The raceways of the guide rails in the Uniline linear axes are prelubricated. To achieve the calculated service life, a lubrication film must always be present between the raceway and the roller. The lubrication film also provides anticorrosion protection to the ground raceways. An approximate value for the lubrication period is every 100 km or every six months. The recommended lubricant is a lithium-based roller bearing grease of medium consistency.

Lubrication of the raceways

Proper lubrication under normal conditions:

- reduces friction
- reduces wear
- reduces stress on the contact faces
- reduces running noise

Lubricants	Thickeners	Temperature range [°C]	Dynamic viscosity [mPas]
Roller bearing grease	Lithium soap	-30 to +170	<4500

Tab. 52

Relubrication of the guide rails

1. Slide the slider plate to one end of the unit.
2. At about half the stroke press and manually move the belt in order to see one of the two rails inside the unit (see Fig. 40).
It may be necessary to release or loosen the belt tension. See chapter Belt tension (pg. US-63).
3. By using a grease syringe (not supplied by ROLLON) or an alternative tool (i.e. brush), apply a sufficient quantity of grease on the raceways.
4. If required, re-establish the recommended belt tension (see pg. US-63).
5. Finally slide the slider plate back and forth over the entire stroke, in order to distribute the grease over the entire length of the rail.

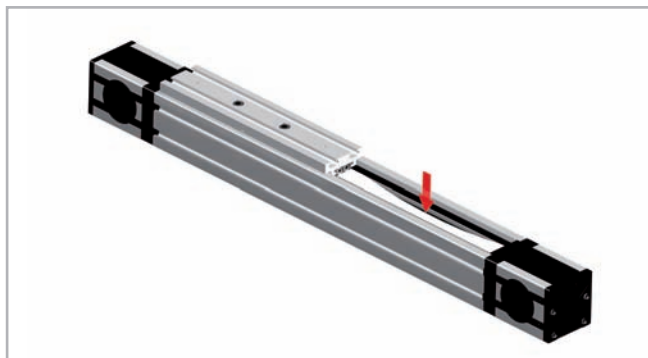

Fig. 40

Cleaning the guide rails

It is always recommended to clean the slider rail prior to any relubrication, in order to remove grease residues. This can be done while performing maintenance work or during a scheduled machine stop.

1. Unscrew the safety screws C (on top of the slider plate) from the belt tensioning device A (see fig. 41).
2. Also completely unscrew the belt tensioning screws B and remove the belt tensioning devices A from their housings.
3. Lift the toothed belt until the guide rails can be seen.
Important: Ensure that the side seal is not damaged.
4. Clean the rail raceways with a clean and dry cloth. Ensure that all grease and dirt residues from previous work processes are removed.
To ensure that the rails are cleaned over their entire length, the slider plate should be moved once over its entire length.
5. Apply a sufficient amount of grease to the raceways.

6. Re-insert the belt tensioning devices A into their housings and mount the belt tensioning screws B. Re-adjust the belt tension (see pg. US-63).
7. Fasten the safety screws C.

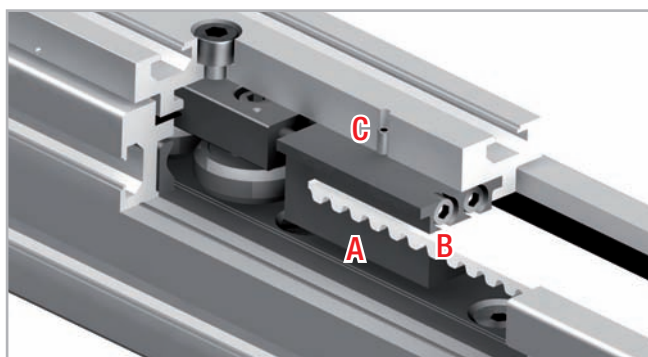

Fig. 41

Accessories

Adapter plates

Standard motor adapter plates AC2

Mounting plates for the most common motors or gearboxes. The connection bores for the motors or gearboxes must be made on site. All plates are delivered with M6 x 10 screws to DIN 912 and T-nuts for mounting on the linear units.

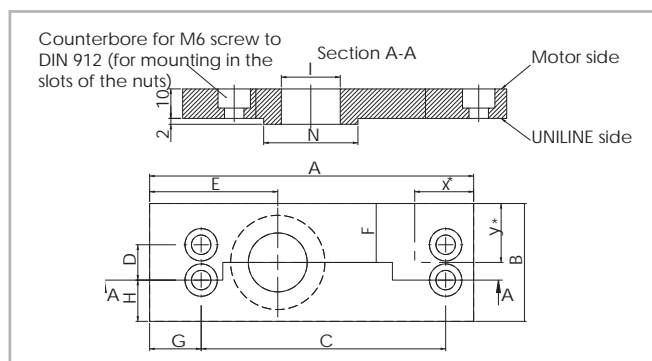

Fig. 42

Size	A [mm]	B [mm]	C [mm]	D [mm]	E [mm]	F [mm]	G [mm]	H [mm]	I [mm]	N [mm]
55	126	55	100	25	50.5	27.5	18	15	∅ 30	∅ 47
75	135	70	106	35	53.5	35	19	17.5	∅ 35	∅ 55

Tab. 53

NEMA plates AC1-P

Mounting plates for NEMA motors or gearboxes. These plates are delivered ready-to-mount on the linear axes. All plates are delivered with M6 x 10 screws to DIN 912 and T-nuts for mounting on the linear units.

Size	NEMA Motors / Gearboxes
55	NEMA 34
75	NEMA 42

Tab. 54

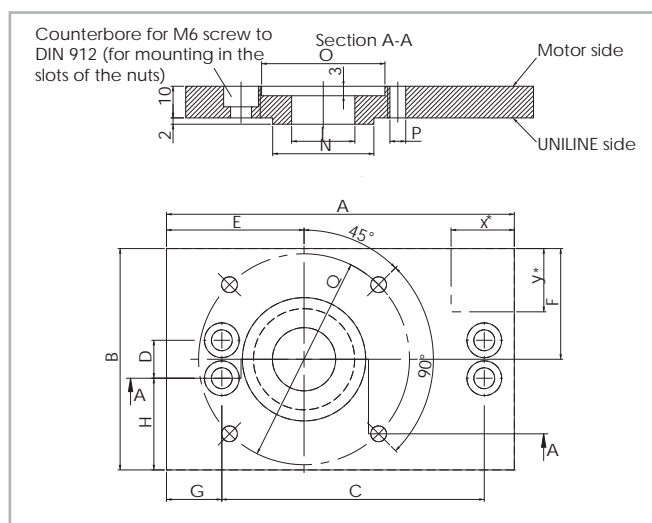

Fig. 43

Size	A [mm]	B [mm]	C [mm]	D [mm]	E [mm]	F [mm]	G [mm]	H [mm]	I [mm]	N [mm]	O [mm]	P [mm]	Q [mm]
55	126	100	100	25	50.5	50	18	37.5	30	∅ 47	∅ 74	∅ 5.5	∅ 98.4
75	135	120	106	35	53.5	60	19	42.5	35	∅ 55	∅ 57	∅ 7.1	∅ 125.7

Tab. 55

Synchronous use of linear axes in pairs

If two axes are to be used in parallel using a connecting shaft, please specify when ordering, to ensure that the key slots of the pulleys are synchronized.

Fixing brackets APF-2

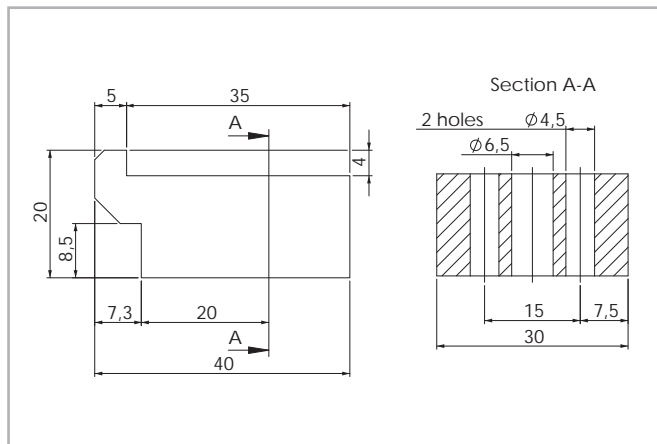

Fig. 44

Fixing clamp for simple mounting of a linear axis on a mounting surface or for connecting two units with or without a connection plate (see pg. US-68).

A spacer* may be necessary.

*(Any spacer that may be necessary must be manufactured on site)

T-nut

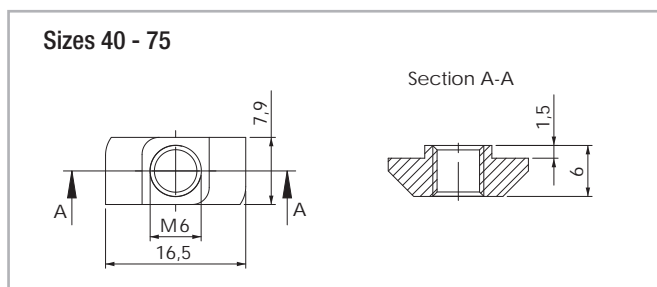

Fig. 45

The maximum tightening torque is 10 Nm.

Assembly kits

T-connection plate APC-1

T-connection plate allows two units to be mounted perpendicular to each other (see pg. US-65). The plate will not interfere with the strokes of either unit. All plates are delivered with M6 x 10 screws to DIN 912 and T-nuts for mounting on the linear units.

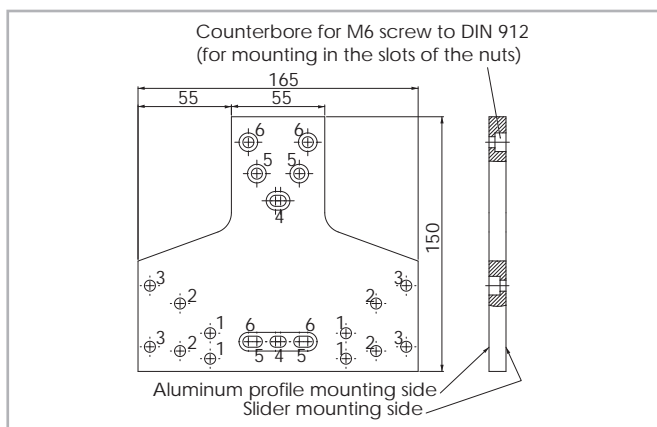

Fig. 46

Size	Fixing holes for the slider	Fixing holes for the profile
55	Holes 2	Holes 5
75	Holes 3	Holes 6

Tab. 56

Angle connection plate APC-2

allows the right angle mounting of two units. The trolley of one unit can be mounted to the side of the other (see pg. US-66). The plate will not interfere with the strokes of either unit. All plates are delivered with M6 x 10 screws to DIN 912 and T-nuts for mounting to the linear units.

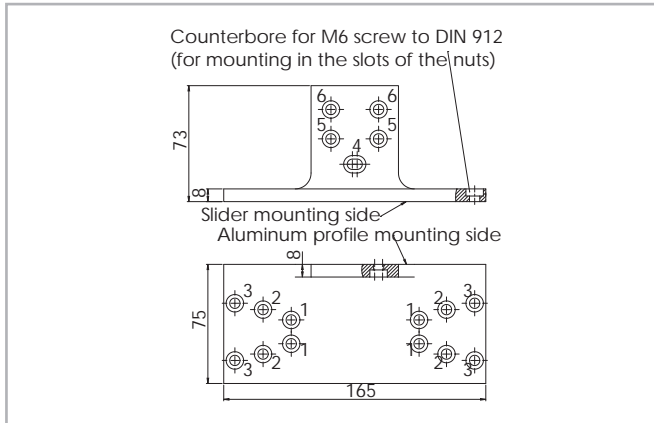

Fig. 47

Size	Fixing holes for the slider	Fixing holes for the profile
55	Holes 2	Holes 5
75	Holes 3	Holes 6

Tab. 57

X connection plate APC-3

X connection plate for mounting two sliders perpendicular to each other (see pg. US-67). The plate will not interfere with the strokes of either unit. All plates are delivered with M6 x 10 screws to DIN 912 and T-nuts for mounting on the linear units.

Size	Fixing holes for slider 1	Fixing holes for slider 2
55	Holes 2	Holes 5
75	Holes 3	Holes 6

Tab. 58

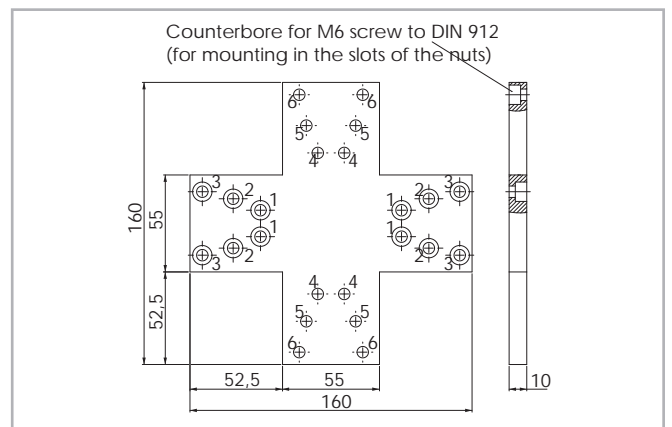

Fig. 48

Ordering key 

> **Identification code for Uniline linear unit**

U	C	07	1A	1190	1A	D 500	L 350
		05=55 07=75					Indices of long slider plate <i>see from pg. US-22 to pg. US-24</i>
							Indices of double slider plate, <i>distance of the centers of slider plates</i> <i>see from pg. US-22 to pg. US-24</i>
							Profile/Rail code
							L= Total length of the unit
							Driving head code
							Size <i>see from pg. US-22 to pg. US-24</i>
							Type
							Uniline prefix

Ordering example: UC 07 1A 1190 1A D 500 L 350

In order to create identification codes for Actuator Line, you can visit: <http://configureactuator.rollon.com>

> Accessories

Standard motor adapter plate

C	07	AC2	
	05=55		Standard motor adapter plates <i>see pg. US-27</i>
	07=75		
	Size		<i>see pg. US-27</i>
Type			

Ordering example: C07-AC2

NEMA motor adapter plates

C	07	AC1	
	05=55		NEMA motor adapter plates <i>see pg. US-27</i>
	07=75		
	Size		<i>see pg. US-27</i>
Type			

Ordering example: C07-AC1

T-connection plate Order code: APC-1, s. pg. US-28

Angle connection plate Order code: APC-2, s. pg. US-29

X connection plate Order code: APC-3, s. pg. US-29

Fixing clamp Order code: APF-2, s. pg. US-28

Motor connection bores

Hole [Ø]	Size		Head code
	55	75	
Metric [mm] with slot for key	12G8 / 4js9	14G8 / 5js9	1A
	10G8 / 3js9	16G8 / 5js9	2A
	14G8 / 5js9	19G8 / 6js9	3A
	16G8 / 5js9		4A
Metric [mm] for compression coupling		18	1B
		24	2B
Inch [in] with slot for key	1/2 / 1/8	5/8 / 3/16	1P
	3/8 / 1/8		2P
	5/8 / 3/16		3P

Tab. 59

The highlighted connection bores are standard connections

Metric: key seat for keys to DIN 6885 form A

Inch: key seat for keys to BS 46 Part 1: 1958

Uniline E series



> Uniline E series description



Fig. 49

Uniline is a family of ready-to-install linear actuators. They consist of internal Compact Rail roller sliders and steel-reinforced polyurethane belts in a rigid aluminum profile. Longitudinal seals enclose the system. This arrangement provides the best protection for the actuator from soiling and damage. In the E series, the fixed bearing rail (T-rail) is mounted horizontally in the aluminum profile, and the compensating bearing rail (U-rail) is flanged to the outside of the profile as moment support. Versions with long (L) or double (D) sliders in one axis are possible.

The most important characteristics:

- Compact design
- Protected internal linear guides
- High traversing speeds
- Grease-free operation possible (depending on the application. For further information, please contact our Application Engineering department)
- High versatility
- Long strokes
- Versions with long or multiple sliders available in one linear axis

Preferred areas of application:

- Handling and automation
- Multi-axis gantries
- Packaging machines
- Cutting machines
- Displaceable panels
- Painting installations
- Welding robots
- Special machines

Technical data:

- Available sizes [mm]:
Type E: 55, 75
- Length and stroke tolerances:
For strokes <1 m: +0 mm to +10 mm (+0 in to 0.4 in)
For strokes >1 m: +0 mm to +15 mm (+0 in to 0.59 in)

> The components

Extruded profile

The anodized 6060 aluminum alloy extrusion used for the profile of the Rollon Uniline E series linear units were designed and manufactured by industry experts to optimize weight while maintaining mechanical strength. (see physical-chemical characteristics below). The dimensional tolerances comply with EN 755-9 standard.

Driving belt

The Rollon Uniline E series linear units use steel reinforced polyurethane drive belts with RPP pitch and parabolic profiles. This belt is ideal due to its high load transmission characteristics, compact size and low noise. Used in conjunction with a backlash-free pulley, smooth alternating motion can

be achieved. Optimization of the maximum belt width/body dimension ratio enables the following performance characteristics to be achieved:

- High speed
- Low noise
- Low wear

Carriage

The carriage of the Rollon Uniline E series linear units are made entirely of anodized aluminum. Each carriage has mounting T-slots for the connection to the moving element. Rollon offers multiple carriages to accommodate a vast array of applications.

General data about aluminum used: AL 6060

Chemical composition [%]

Al	Mg	Si	Fe	Mn	Zn	Cu	Impurites
Remainder	0.35-0.60	0.30-0.60	0.30	0.10	0.10	0.10	0.05-0.15

Tab. 60

Physical characteristics

Density	Coeff. of elasticity	Coeff. of thermal expansion (20°-100°C)	Thermal conductivity (20°C)	Specific heat (0°-100°C)	Resistivity	Melting point
$\frac{\text{kg}}{\text{dm}^3}$	$\frac{\text{kN}}{\text{mm}^2}$	$\frac{10^{-6}}{\text{K}}$	$\frac{\text{W}}{\text{m} \cdot \text{K}}$	$\frac{\text{J}}{\text{kg} \cdot \text{K}}$	$\Omega \cdot \text{m} \cdot 10^{-9}$	°C
2.7	69	23	200	880-900	33	600-655

Tab. 61

Mechanical characteristics

Rm	Rp (02)	A	HB
$\frac{\text{N}}{\text{mm}^2}$	$\frac{\text{N}}{\text{mm}^2}$	%	—
205	165	10	60-80

Tab. 62

> E55

E55 system

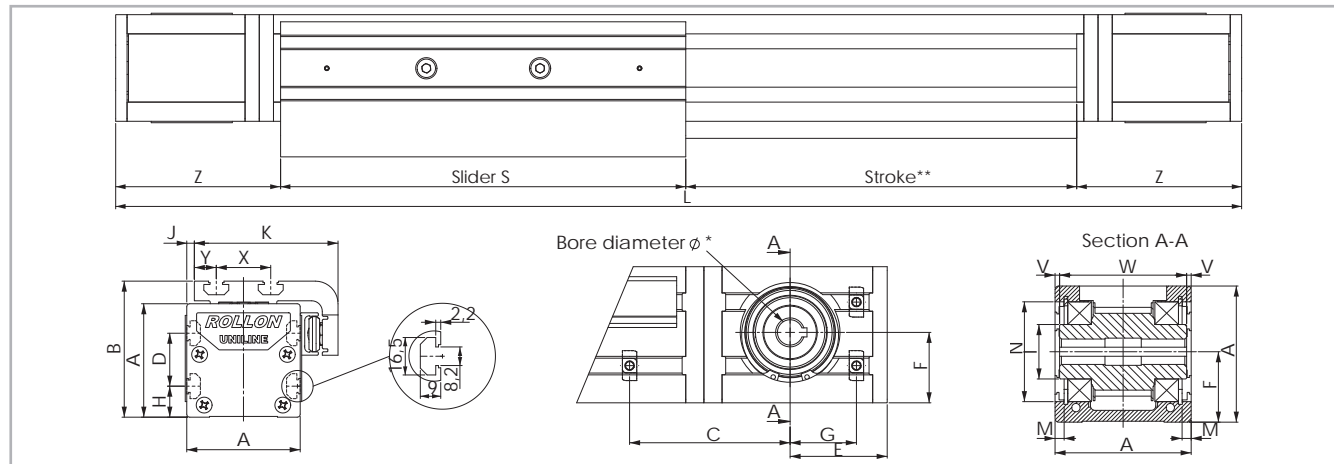

* For information on the motor connection bores, see ordering key. ** The length of the safety stroke is provided on request according to the customer's specific requirements. Fig. 50

Type	A [mm]	B [mm]	C* [mm]	D [mm]	E [mm]	F [mm]	G* [mm]	H [mm]	I [mm]	J [mm]	K [mm]	M [mm]	N [mm]	S [mm]	X [mm]	Y [mm]	V [mm]	W [mm]	Z [mm]	Stroke** [mm]
E55	55	71	67.5	25	50.5	27.5	32.5	15	∅ 24.9	1.5	71	2.35	∅ 47	200	28	12	0.5	54	108	3070

* For the position of the T-nuts when using our motor adapter plates, see pg. US-39ff Tab. 63

** Maximum stroke for a single-piece guiding rail. For longer strokes, see tab. 68

E55L with long slider

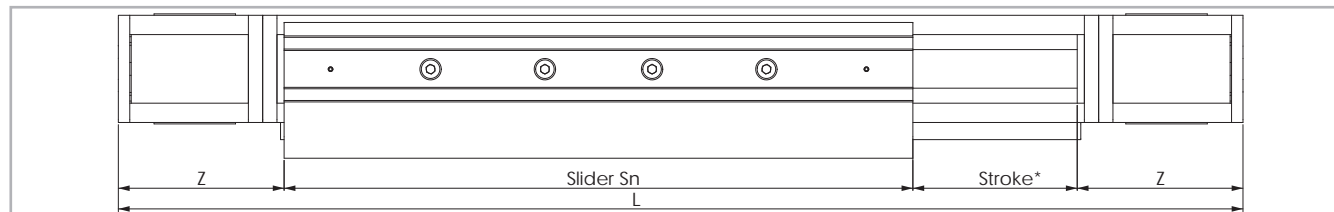

* The length of the safety stroke is provided on request according to the customer's specific requirements. Fig. 51

Type	S _{min} [mm]	S _{max} [mm]	Sn [mm]	Z [mm]	Stroke* [mm]
E55L	310	500	$S_n = S_{min} + n \cdot 10$	108	2770

* Maximum stroke for a single-piece guiding rail and a maximum slider plate length S_{max} For longer strokes, see tab. 68 Tab. 64

E55D with double slider

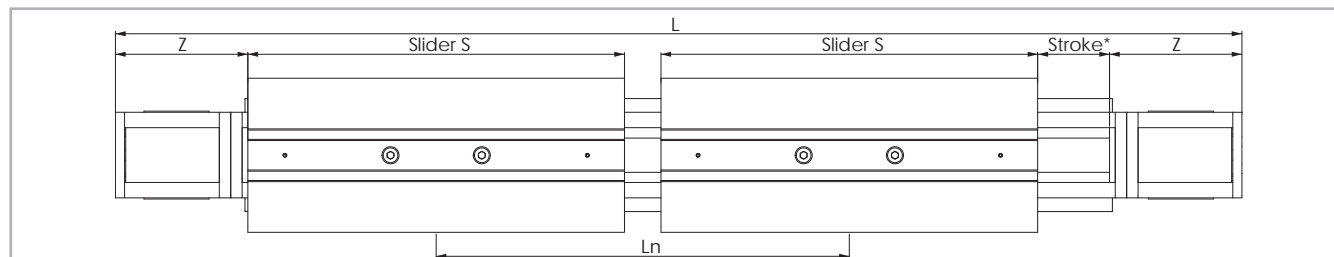

* The length of the safety stroke is provided on request according to the customer's specific requirements. Fig. 52

Type	S [mm]	L _{min} [mm]	L _{max} ** [mm]	Ln [mm]	Z [mm]	Stroke* [mm]
E55D	200	300	3070	$L_n = L_{min} + n \cdot 5$	108	2770

* Maximum stroke for a single-piece guiding rail and a minimum slider plate distance L_{min} Tab. 65

** Maximum distance L_{max} between the centres of slider plates at a stroke of 0 mm For longer strokes, see tab. 68

> Load ratings, moments and characteristic data

E55

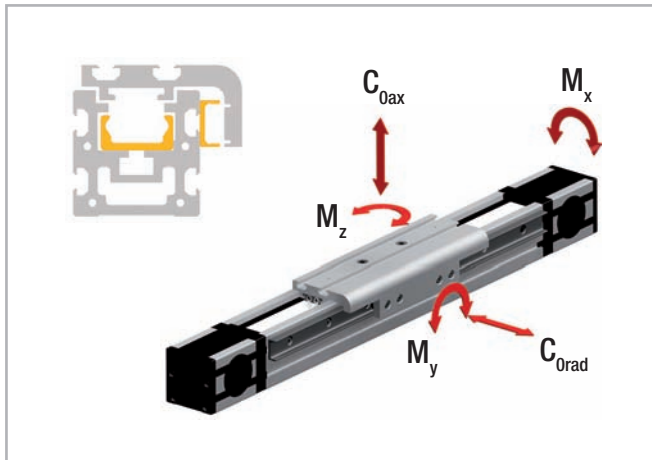

Fig. 53

Driving belt

The driving belt is manufactured from a friction resistant polyurethane and with steel cords for high tensile stress resistance.

Type	Type of belt	Belt width [mm]	Weight kg/m
E55	18RPP5	18	0.074

Tab. 66

Belt length (mm) = 2 x L - 182 Standard slider

Belt length (mm) = 2 x L - S_n+18 Long slider

Belt length (mm) = 2 x L - L_n - 182 Double slider

Type	C [N]	C _{0rad} [N]	C _{0ax} [N]	M _x [Nm]	M _y [Nm]	M _z [Nm]
E55	4260	2175	1500	25.5	43.4	54.4
E55-L	8520	4350	3000	51	165 to 450	239 to 652
E55-D	8520	4350	3000	51	450 to 4605	652 to 6677

For the calculation of the allowed moments, please observe pages SL-5ff

Tab. 67

Technical data	Type
	E55
Standard belt tension [N]	220
Moment at no load [Nm]	0.3
Max. traversing speed [m/s]	3
Max. acceleration [m/s ²]	10
Repeat accuracy [mm]	0.1
Linear accuracy [mm]	0.8
Compact Rail guiding rail	TLV28 / ULV18
Slider type	CS28 spec. / CPA 18
Moment of inertia I _y [cm ⁴]	34.6
Moment of inertia I _z [cm ⁴]	41.7
Pitch diameter of pulley [m]	0.04138
Moment of inertia of each pulley [gmm ²]	45633
Stroke per shaft revolution [mm]	130
Mass of slider [g]	635
Weight with zero stroke [g]	3167
Weight with 1 m stroke [g]	5055
Max. stroke [mm]	5500
Working temperature	from -20 °C to + 80 °C

Tab. 68

> E75

E75 system

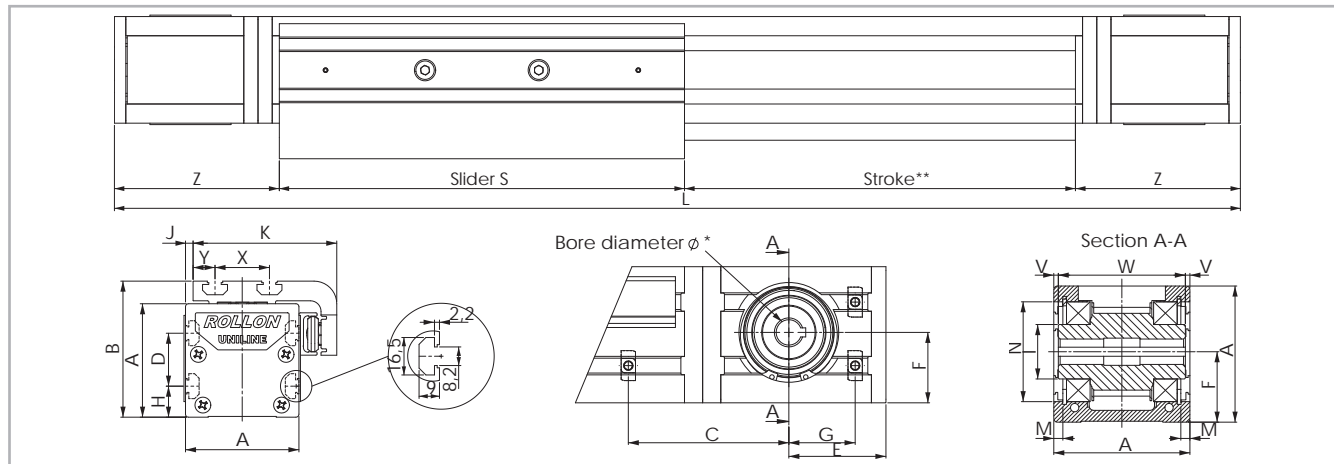

* For information on the motor connection bores, see ordering key. ** The length of the safety stroke is provided on request according to the customer's specific requirements. Fig. 54

Type	A [mm]	B [mm]	C* [mm]	D [mm]	E [mm]	F [mm]	G* [mm]	H [mm]	I [mm]	J [mm]	K [mm]	M [mm]	N [mm]	S [mm]	X [mm]	Y [mm]	V [mm]	W [mm]	Z [mm]	Stroke** [mm]
E75	75	90	71.5	35	53.5	38.8	34.5	20	∅ 29.5	5	95	4.85	∅ 55	285	36	14.5	2.3	70.4	116	3420

* For the position of the T-nuts when using our motor adapter plates, see pg. US-39ff
 ** Maximum stroke for a single-piece guiding rail. For longer strokes, see tab. 74 Tab. 69

E75L with long slider

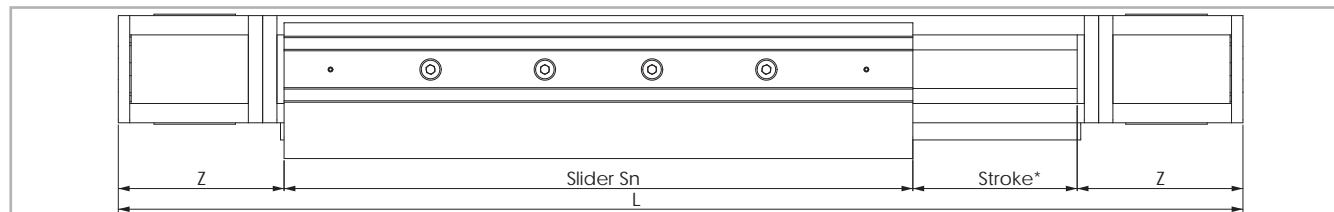

* The length of the safety stroke is provided on request according to the customer's specific requirements. Fig. 55

Type	S _{min} [mm]	S _{max} [mm]	Sn [mm]	Z [mm]	Stroke* [mm]
E75L	440	700	$S_n = S_{min} + n \cdot 10$	116	3000

* Maximum stroke for a single-piece guiding rail and a maximum slider plate length S_{max}
 For longer strokes, see tab. 74 Tab. 70

E75D with double slider

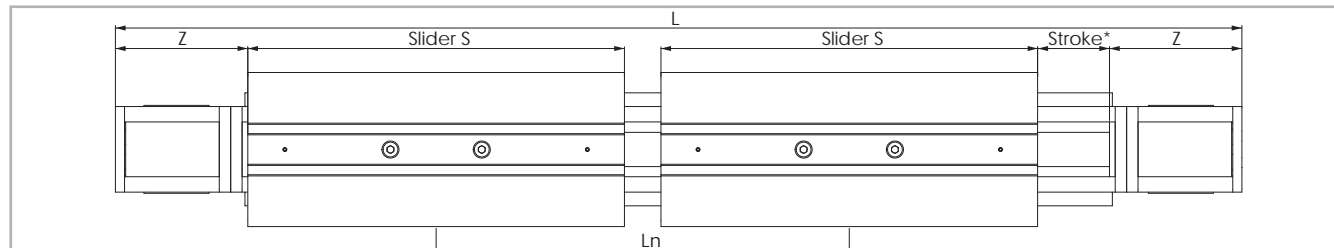

* The length of the safety stroke is provided on request according to the customer's specific requirements. Fig. 56

Type	S [mm]	L _{min} [mm]	L _{max} ** [mm]	Ln [mm]	Z [mm]	Stroke* [mm]
E75D	285	416	3416	$L_n = L_{min} + n \cdot 8$	116	3000

* Maximum stroke for a single-piece guiding rail and a minimum slider plate distance L_{min}
 ** Maximum distance L_{max} between the centres of slider plates at a stroke of 0 mm
 For longer strokes, see tab. 74 Tab. 71

> Load ratings, moments and characteristic data

E75

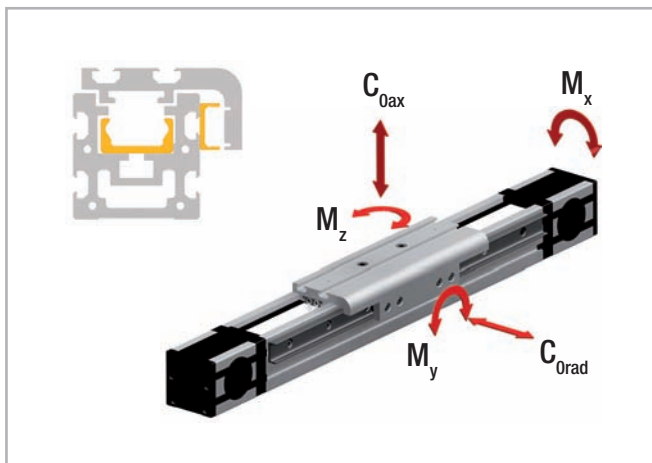

Fig. 57

Driving belt

The driving belt is manufactured from a friction resistant polyurethane and with steel cords for high tensile stress resistance.

Type	Type of belt	Belt width [mm]	Weight kg/m
E75	30RPP8	30	0.185

Tab. 72

Belt length (mm) = 2 x L - 213 Standard slider

Belt length (mm) = 2 x L - S_n+72 Long slider

Belt length (mm) = 2 x L - L_n - 213 Double slider

Type	C [N]	C _{0rad} [N]	C _{0ax} [N]	M _x [Nm]	M _y [Nm]	M _z [Nm]
E75	12280	5500	3710	85.5	163	209
E75-L	24560	11000	7420	171	575 to 1540	852 to 2282
E75-D	24560	11000	7420	171	1543 to 12673	2288 to 18788

For the calculation of the allowed moments, please see pages SL-5ff

Tab. 73

Technical data	Type
	E75
Standard belt tension [N]	800
Moment at no load [Nm]	1.3
Max. traversing speed [m/s]	5
Max. acceleration [m/s ²]	15
Repeat accuracy [mm]	0.1
Linear accuracy [mm]	0.8
Compact Rail guiding rail	TLV43 / ULV28
Slider type	CS43 spec. / CPA 28
Moment of inertia I _y [cm ⁴]	127
Moment of inertia I _z [cm ⁴]	172
Pitch diameter of pulley [m]	0.05093
Moment of inertia of each pulley [gmm ²]	139969
Stroke per shaft revolution [mm]	160
Mass of slider [g]	1772
Weight with zero stroke [g]	7544
Weight with 1 m stroke [g]	10751
Max. stroke [mm]	7500
Working temperature	from -20 °C to + 80 °C

Tab. 74

> Lubrication

The raceways of the guide rails in the Uniline linear axes are prelubricated. To achieve the calculated service life, a lubrication film must always be present between the raceway and the roller. The lubrication film also provides anticorrosion protection to the ground raceways. An approximate value for the lubrication period is every 100 km or every six months. The recommended lubricant is a lithium-based roller bearing grease of medium consistency.

Lubrication of the raceways

Proper lubrication under normal conditions:

- reduces friction
- reduces wear
- reduces stress on the contact faces
- reduces running noise

Lubricants	Thickeners	Temperature range [°C]	Dynamic viscosity [mPas]
Roller bearing grease	Lithium soap	-30 to +170	<4500

Tab. 75

Relubrication of the guide rails

These types of rails have a lubricating conduit on the side of the slider plate through which the lubricant can be applied directly to the raceways. Lubrication can be done in one of two ways:

1. Relubrication using a grease gun:

This is done by inserting the tip of the grease gun into the conduit at the slider plate and injecting the grease inside (see fig. 58). Please note that the grease has to fill the whole conduit in order to lubricate the rail properly; for this reason sufficient grease must be used.

2. Automatic lubrication system:

To connect the unit to an automatic greasing system, use a proper adapter/connector* that attaches to the threaded hole on the side of the trolley.

The advantage of this solution is the possibility of rail re-lubrication without machine downtime.

*(Any adapter that may be necessary must be manufactured on site)

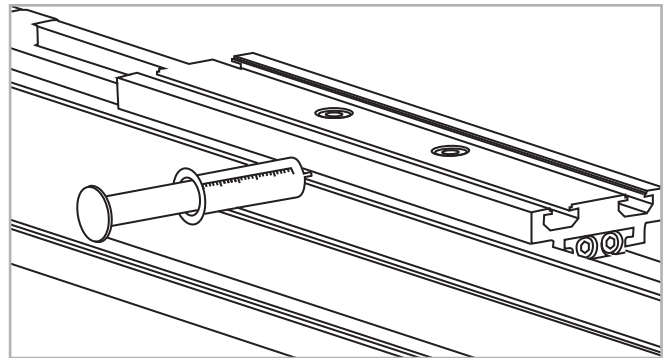

Fig. 58

Cleaning the guide rails

It is always recommended to clean the slider rail prior to any relubrication, in order to remove grease residues. This can be done while performing maintenance work or during a scheduled machine stop.

1. Unscrew the safety screws C (on top of the slider plate) from the belt tensioning device A (see fig. 59).
2. Also completely unscrew the belt tensioning screws B and remove the belt tensioning devices A from their housings.
3. Lift the toothed belt until the guide rails can be seen.
Important: Ensure that the side seal is not damaged.
4. Clean the rail raceways with a clean and dry cloth. Ensure that all grease and dirt residues from previous work processes are removed.
To ensure that the rails are cleaned over their entire length, the slider plate should be moved once over its entire length.
5. Apply a sufficient amount of grease to the raceways.

6. Re-insert the belt tensioning devices A into their housings and mount the belt tensioning screws B. Re-adjust the belt tension (see pg. US-63).
7. Fasten the safety screws C.

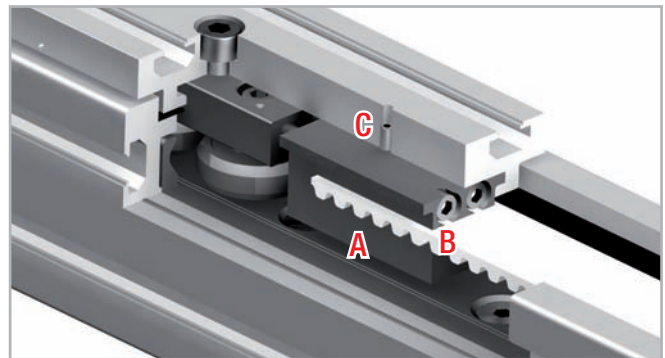

Fig. 59

> Accessories

Adapter plates

Standard motor adapter plates AC2

Mounting plates for the most common motors or gearboxes. The connection bores for the motors or gearboxes must be made on site. All plates are delivered with M6 x 10 screws to DIN 912 and T-nuts for mounting on the linear units.

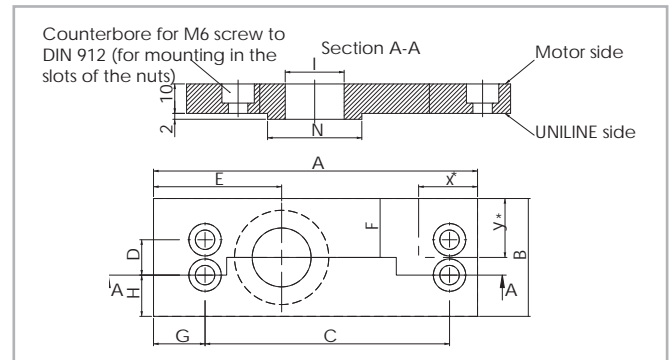

Fig. 60

Size	A [mm]	B [mm]	C [mm]	D [mm]	E [mm]	F [mm]	G [mm]	H [mm]	I [mm]	N [mm]
55	126	55	100	25	50.5	27.5	18	15	Ø 30	Ø 47
75	135	70	106	35	53.5	35	19	17.5	Ø 35	Ø 55

Tab. 76

NEMA plates AC1-P

Mounting plates for NEMA motors or gearboxes. These plates are delivered ready-to-mount on the linear axes. All plates are delivered with M6 x 10 screws to DIN 912 and T-nuts for mounting on the linear units.

Size	NEMA Motors / Gearboxes
55	NEMA 34
75	NEMA 42

Tab. 77

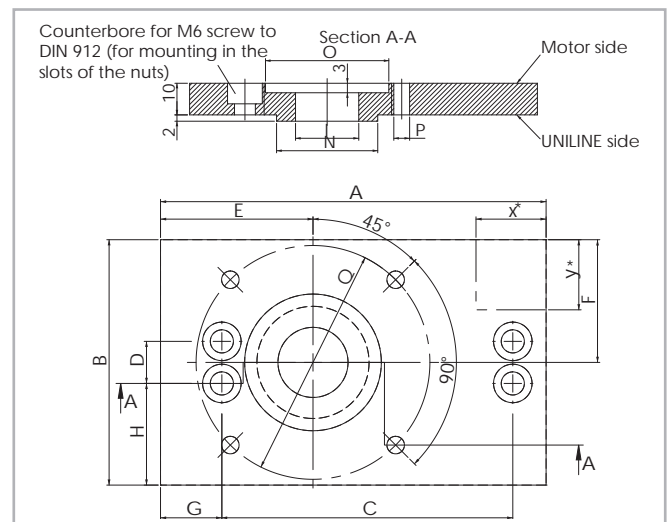

Fig. 61

Size	A [mm]	B [mm]	C [mm]	D [mm]	E [mm]	F [mm]	G [mm]	H [mm]	I [mm]	N [mm]	O [mm]	P [mm]	Q [mm]
55	126	100	100	25	50.5	50	18	37.5	30	Ø 47	Ø 74	Ø 5.5	Ø 98.4
75	135	120	106	35	53.5	60	19	42.5	35	Ø 55	Ø 57	Ø 7.1	Ø 125.7

Tab. 78

Synchronous use of linear axes in pairs

If two axes are to be used in parallel using a connecting shaft, please specify when ordering, to ensure that the key slots of the pulleys are synchronized.

Fixing brackets APF-2

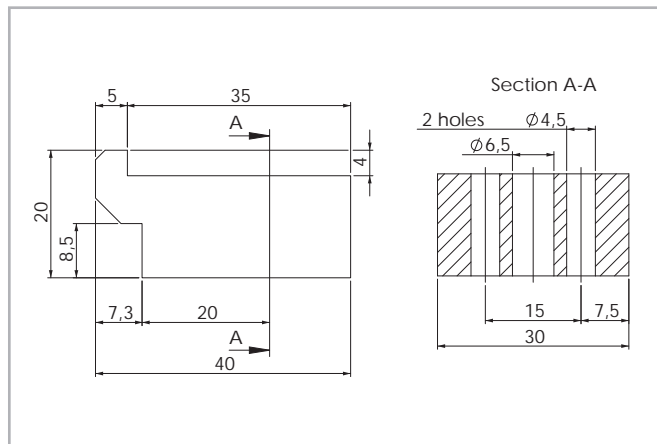

Fig. 62

Fixing clamp for simple mounting of a linear axis on a mounting surface or for connecting two units with or without a connection plate (see pg. US-68).

A spacer* may be necessary.

*(Any spacer that may be necessary must be manufactured on site)

T-nut

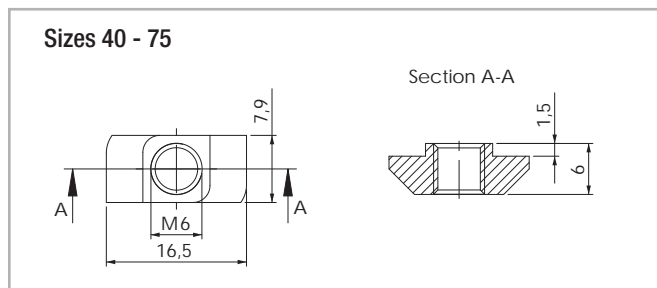

Fig. 63

The maximum tightening torque is 10 Nm.

Assembly kits

T-connection plate APC-1

T-connection plate allows two units to be mounted perpendicular to each other (see pg. US-65). The plate will not interfere with the strokes of either unit. All plates are delivered with M6 x 10 screws to DIN 912 and T-nuts for mounting on the linear units.

Note

This adapter plate can be used with types E and ED only to a limited extent. For further information, please contact our Application Engineering Department.

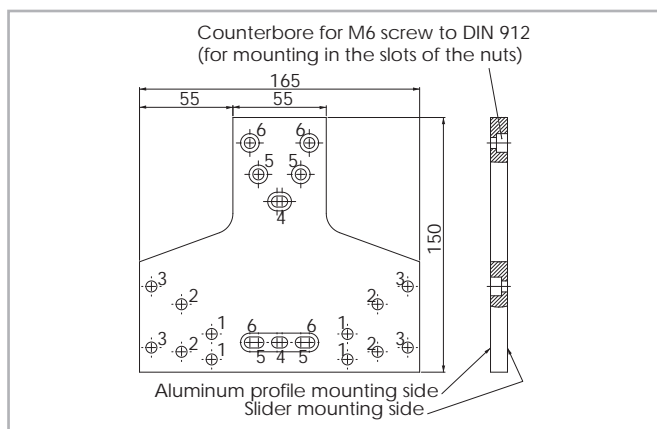

Fig. 64

Size	Fixing holes for the slider	Fixing holes for the profile
55	Holes 2	Holes 5
75	Holes 3	Holes 6

Tab. 79

Angle connection plate APC-2

allows the right angle mounting of two units. The trolley of one unit can be mounted to the side of the other (see pg. US-66). The plate will not interfere with the strokes of either unit. All plates are delivered with M6 x 10 screws to DIN 912 and T-nuts for mounting to the linear units.

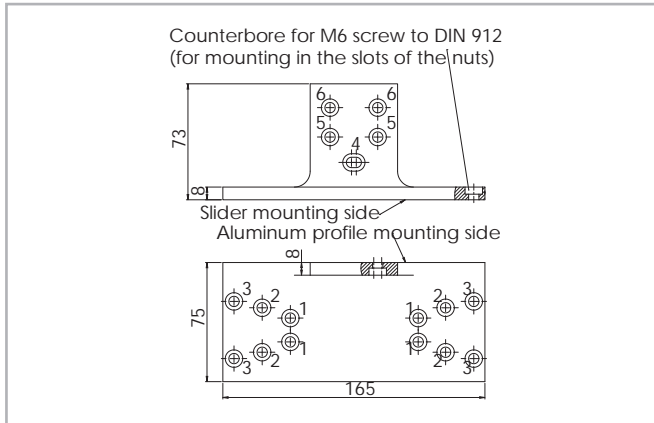

Fig. 65

Note

This adapter plate can be used with types E and ED only to a limited extent. For further information, please contact our Application Engineering Department.

Size	Fixing holes for the slider	Fixing holes for the profile
55	Holes 2	Holes 5
75	Holes 3	Holes 6

Tab. 80

X connection plate APC-3

X connection plate for mounting two sliders perpendicular to each other (see pg. US-67). The plate will not interfere with the strokes of either unit. All plates are delivered with M6 x 10 screws to DIN 912 and T-nuts for mounting on the linear units.

Size	Fixing holes for slider 1	Fixing holes for slider 2
55	Holes 2	Holes 5
75	Holes 3	Holes 6

Tab. 81

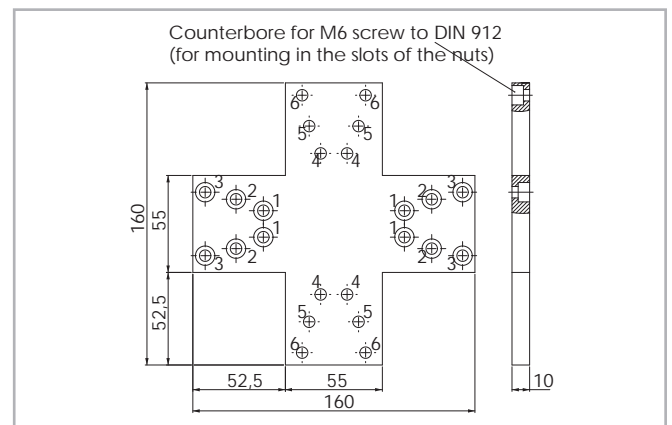

Fig. 66

Ordering key 

> Identification code for Uniline linear unit

U	E	07 05=55 07=75	1A	1190	1A	D 500	L 350
						Indices of long slider plate <i>see from pg. US-34 to pg. US-36</i>	
						Indices of double slider plate, <i>distance of the centers of slider plates</i> <i>see from pg. US-34 to pg. US-36</i>	
						Profile/Rail code	
						L= Total length of the unit	
						Driving head code	
						Size <i>see from pg. US-34 to pg. US-36</i>	
						Type	
Uniline prefix							

Ordering example: UE 07 1A 1190 1A D 500 L 350

In order to create identification codes for Actuator Line, you can visit: <http://configureactuator.rollon.com>

> Accessories

Standard motor adapter plate

E	07	AC2	
	05=55		Standard motor adapter plates <i>see pg. US-39</i>
	07=75		
	Size		<i>see pg. US-39</i>
Type			

Ordering example: E07-AC2

NEMA motor adapter plates

E	07	AC1	
	05=55		NEMA motor adapter plates <i>see pg. US-39</i>
	07=75		
	Size		<i>see pg. US-39</i>
Type			

Ordering example: E07-AC1

T-connection plate Order code: APC-1, s. pg. US-40

Angle connection plate Order code: APC-2, s. pg. US-41

X connection plate Order code: APC-3, s. pg. US-41

Fixing clamp Order code: APF-2, s. pg. US-40

Motor connection bores

Hole [Ø]	Size		Head code
	55	75	
Metric [mm] with slot for key	12G8 / 4js9	14G8 / 5js9	1A
	10G8 / 3js9	16G8 / 5js9	2A
	14G8 / 5js9	19G8 / 6js9	3A
	16G8 / 5js9		4A
Metric [mm] for compression coupling		18	1B
		24	2B
Inch [in] with slot for key	1/2 / 1/8	5/8 / 3/16	1P
	3/8 / 1/8		2P
	5/8 / 3/16		3P

Tab. 82

The highlighted connection bores are standard connections

Metric: key seat for keys to DIN 6885 form A

Inch: key seat for keys to BS 46 Part 1: 1958

Uniline ED series



> Uniline ED series description

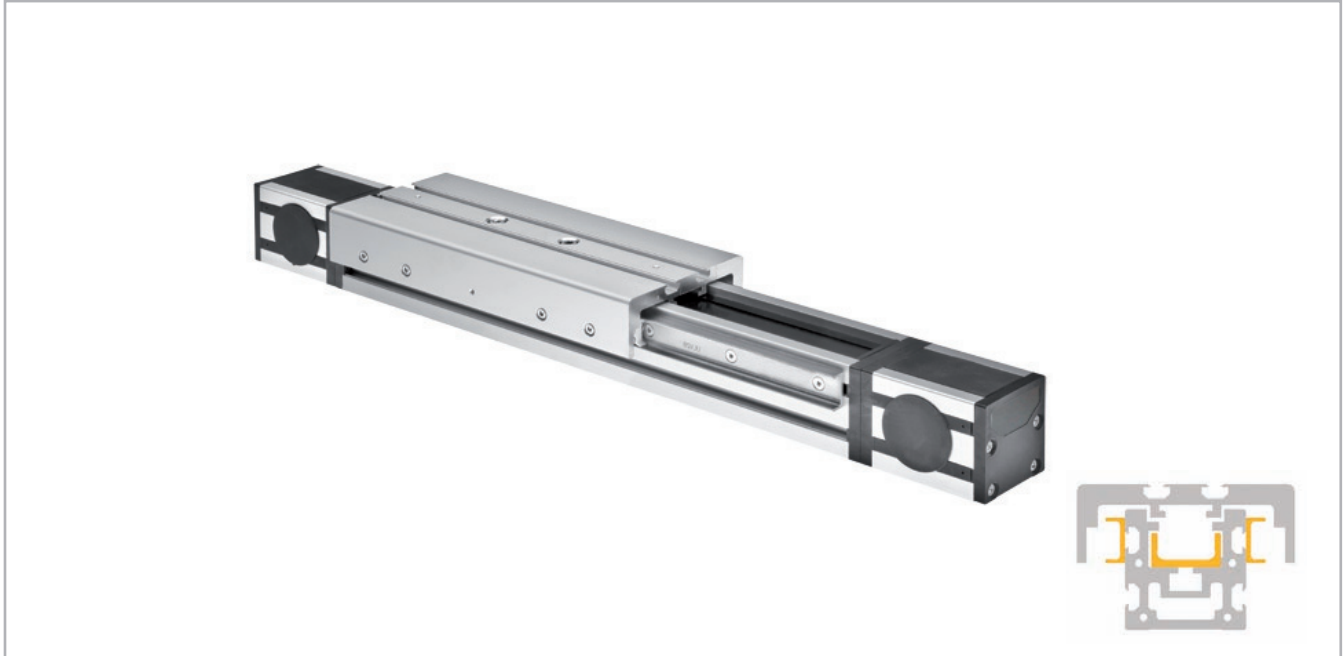

Fig. 67

Uniline is a family of ready-to-install linear actuators. They consist of internal Compact Rail roller sliders and steel-reinforced polyurethane belts in a rigid aluminum profile. Longitudinal seals enclose the system. This arrangement provides the best protection for the actuator from soiling and damage. In the ED series, a compensating bearing rail (U-rail) is mounted horizontally in the aluminum profile, and for increased moment support, two more compensating bearing rails (U-rail) are flanged to the profile externally. Versions with long (L) or double (D) sliders in one axis are possible.

The most important characteristics:

- Compact design
- Protected internal linear guides
- High traversing speeds
- Grease-free operation possible (depending on the application. For further information, please contact our Application Engineering department)
- High versatility
- Long strokes
- Versions with long or multiple sliders available in one linear axis

Preferred areas of application:

- Handling and automation
- Multi-axis gantries
- Packaging machines
- Cutting machines
- Displaceable panels
- Painting installations
- Welding robots
- Special machines

Technical data:

- Available sizes [mm]:
Type ED: 75
- Length and stroke tolerances:
For strokes <1 m: +0 mm to +10 mm (+0 in to 0.4 in)
For strokes >1 m: +0 mm to +15 mm (+0 in to 0.59 in)

> The components

Extruded profile

The anodized 6060 aluminum alloy extrusion used for the profile of the Rollon Uniline ED series linear units were designed and manufactured by industry experts to optimize weight while maintaining mechanical strength. (see physical-chemical characteristics below). The dimensional tolerances comply with EN 755-9 standard.

Driving belt

The Rollon Uniline ED series linear units use steel reinforced polyurethane drive belts with RPP pitch and parabolic profiles. This belt is ideal due to its high load transmission characteristics, compact size and low noise. Used in conjunction with a backlash-free pulley, smooth alternating motion can

be achieved. Optimization of the maximum belt width/body dimension ratio enables the following performance characteristics to be achieved:

- High speed
- Low noise
- Low wear

Carriage

The carriage of the Rollon Uniline ED series linear units are made entirely of anodized aluminum. Each carriage has mounting T-slots for the connection to the moving element. Rollon offers multiple carriages to accommodate a vast array of applications.

General data about aluminum used: AL 6060

Chemical composition [%]

Al	Mg	Si	Fe	Mn	Zn	Cu	Impurites
Remainder	0.35-0.60	0.30-0.60	0.30	0.10	0.10	0.10	0.05-0.15

Tab. 83

Physical characteristics

Density	Coeff. of elasticity	Coeff. of thermal expansion (20°-100°C)	Thermal conductivity (20°C)	Specific heat (0°-100°C)	Resistivity	Melting point
$\frac{\text{kg}}{\text{dm}^3}$	$\frac{\text{kN}}{\text{mm}^2}$	$\frac{10^{-6}}{\text{K}}$	$\frac{\text{W}}{\text{m} \cdot \text{K}}$	$\frac{\text{J}}{\text{kg} \cdot \text{K}}$	$\Omega \cdot \text{m} \cdot 10^{-9}$	°C
2.7	69	23	200	880-900	33	600-655

Tab. 84

Mechanical characteristics

Rm	Rp (02)	A	HB
$\frac{\text{N}}{\text{mm}^2}$	$\frac{\text{N}}{\text{mm}^2}$	%	—
205	165	10	60-80

Tab. 85

> ED75

ED75 system

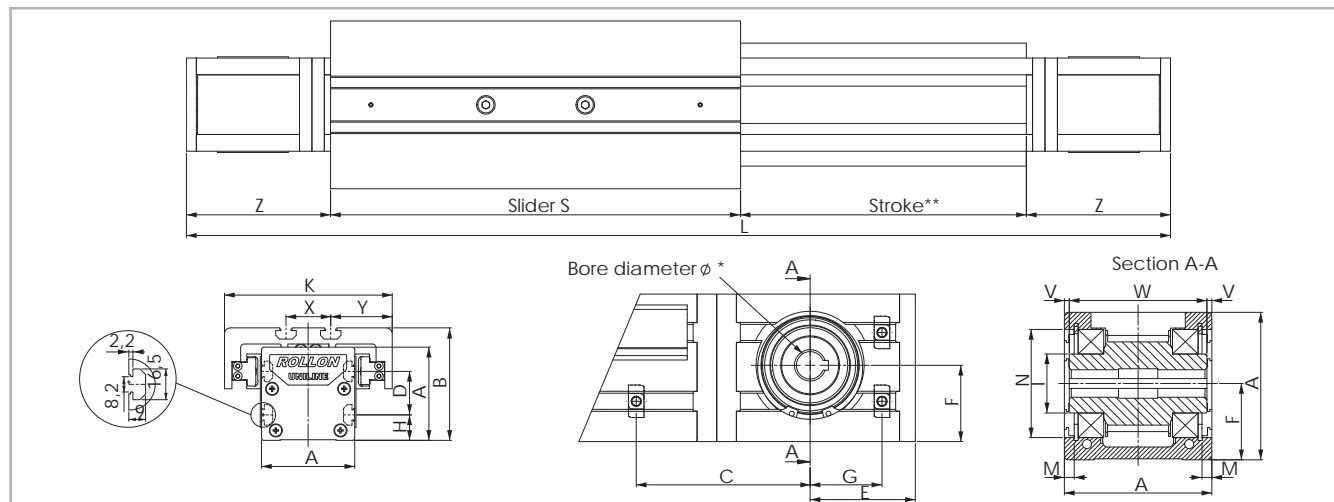

* For information on the motor connection bores, see ordering key. ** The length of the safety stroke is provided on request according to the customer's specific requirements.

Fig. 68

Type	A [mm]	B [mm]	C* [mm]	D [mm]	E [mm]	F [mm]	G* [mm]	H [mm]	I [mm]	K [mm]	M [mm]	N [mm]	S [mm]	X [mm]	Y [mm]	V [mm]	W [mm]	Z [mm]	Stroke** [mm]
ED75	75	90	71.5	35	53.5	38.8	34.5	20	∅ 29.5	135	4.85	∅ 55	330	36	49.5	2.3	70.4	116	2900

* For the position of the T-nuts when using our motor adapter plates, see pg. US-49ff

** Maximum stroke for a single-piece guiding rail. For longer strokes, see tab. 91

Tab. 86

ED75L with long slider

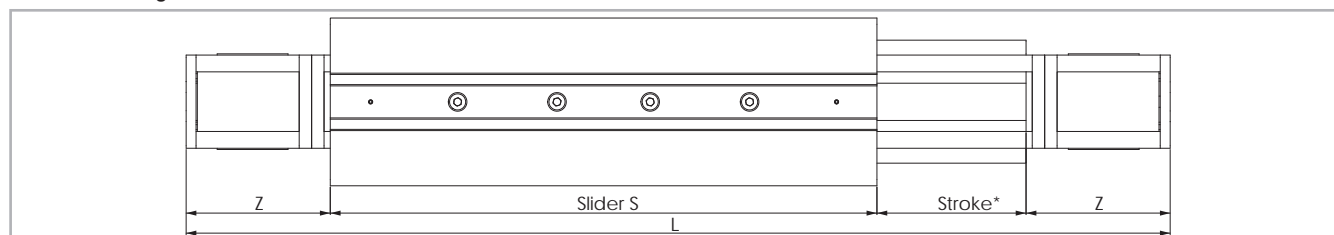

* The length of the safety stroke is provided on request according to the customer's specific requirements.

Fig. 69

Type	S_{min}^* [mm]	S_{max} [mm]	S_n [mm]	Z [mm]	Stroke** [mm]
ED75L	440	700	$S_n = S_{min} + n \cdot 10$	116	2500

* The length of 440 mm is considered standard, all other lengths are considered special dimensions

Tab. 87

** Maximum stroke for a single-piece guiding rail and a maximum slider plate length S_{max} . For longer strokes, see tab. 91

ED75D with double slider

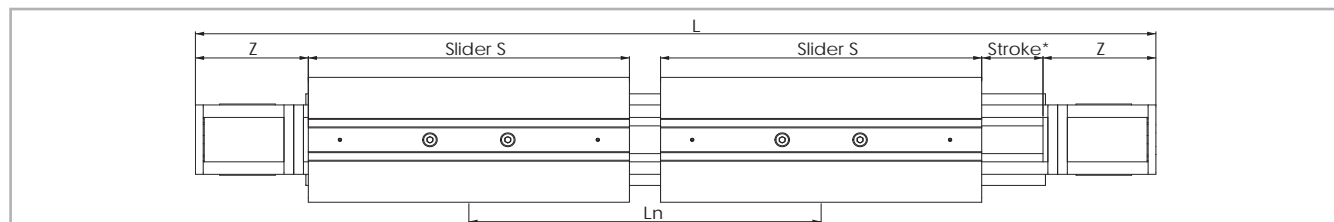

* The length of the safety stroke is provided on request according to the customer's specific requirements.

Fig. 90

Type	S [mm]	L_{min} [mm]	L_{max}^{**} [mm]	L_n [mm]	Z [mm]	Stroke* [mm]
ED75D	330	416	2864	$L_n = L_{min} + n \cdot 8$	116	2450

* Maximum stroke for a single-piece guiding rail and a minimum slider plate distance L_{min}

Tab. 88

** Maximum distance L_{max} between the centres of slider plates at a stroke of 0 mm

For longer strokes, see tab. 91

Type ED

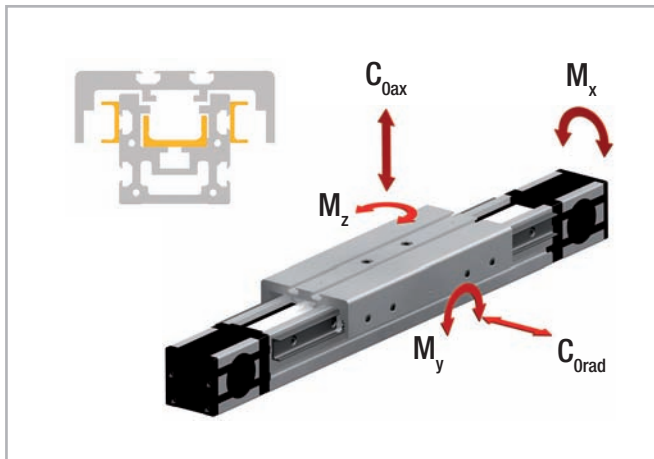

Fig. 71

Driving belt

The driving belt is manufactured from a friction resistant polyurethane and with steel cords for high tensile stress resistance.

Type	Type of belt	Belt width [mm]	Weight kg/m
ED75	30RPP8	30	0.185

Tab. 89

Belt length (mm) = 2 x L - 258 Standard slider

Belt length (mm) = 2 x L - S_n + 72 Long slider

Belt length (mm) = 2 x L - L_n - 258 Double slider

Type	C [N]	C _{0rad} [N]	C _{0ax} [N]	M _x [Nm]	M _y [Nm]	M _z [Nm]
ED75	9815	5500	8700	400.2	868	209
ED75-L	19630	11000	8700	400.2	1174 to 2305	852 to 2282
ED75-D	19630	11000	17400	800.4	3619 to 24917	2288 to 15752

For the calculation of the allowed moments, please see pages SL-5ff

Tab. 90

Technical data	Type
	ED75
Standard belt tension [N]	1000
Moment at no load [Nm]	1.5
Max. traversing speed [m/s]	5
Max. acceleration [m/s ²]	15
Repeat accuracy [mm]	0.1
Linear accuracy [mm]	0.8
Compact Rail guiding rail	ULV43 / ULV28
Slider type	CS43 spec. / CS28 spec.
Moment of inertia I _y [cm ⁴]	127
Moment of inertia I _z [cm ⁴]	172
Pitch diameter of pulley [m]	0.05093
Moment of inertia of each pulley [gmm ²]	139969
Stroke per shaft revolution [mm]	160
Mass of slider [g]	3770
Weight with zero stroke [g]	9850
Weight with 1 m stroke [g]	14400
Max. stroke [mm]	7500
Working temperature	from -20 °C to + 80 °C

Tab. 91

> Lubrication

The raceways of the guide rails in the Uniline linear axes are prelubricated. To achieve the calculated service life, a lubrication film must always be present between the raceway and the roller. The lubrication film also provides anticorrosion protection to the ground raceways. An approximate value for the lubrication period is every 100 km or every six months. The recommended lubricant is a lithium-based roller bearing grease of medium consistency.

Lubrication of the raceways

Proper lubrication under normal conditions:

- reduces friction
- reduces wear
- reduces stress on the contact faces
- reduces running noise

Lubricants	Thickeners	Temperature range [°C]	Dynamic viscosity [mPas]
Roller bearing grease	Lithium soap	-30 to +170	<4500

Tab. 92

Relubrication of the guide rails

1. Slide the slider plate to one end of the unit.
2. At about half the stroke press and manually move the belt in order to see one of the two rails inside the unit (see Fig. 72).
It may be necessary to release or loosen the belt tension. See chapter Belt tension (pg. US-63).
3. By using a grease syringe (not supplied by ROLLON) or an alternative tool (i.e. brush), apply a sufficient quantity of grease on the raceways.
4. If required, re-establish the recommended belt tension (see pg. US-63).
5. Finally slide the slider plate back and forth over the entire stroke, in order to distribute the grease over the entire length of the rail.

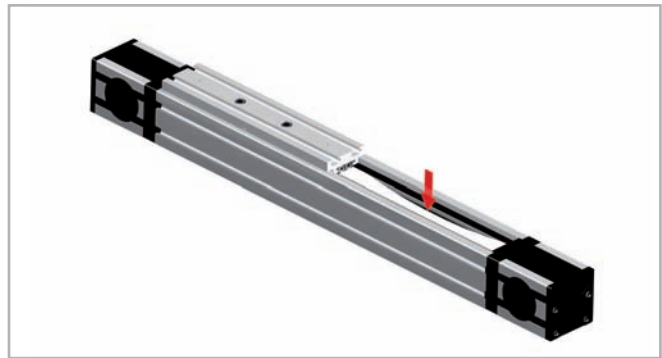

Fig. 72

Cleaning the guide rails

It is always recommended to clean the slider rail prior to any relubrication, in order to remove grease residues. This can be done while performing maintenance work or during a scheduled machine stop.

1. Unscrew the safety screws C (on top of the slider plate) from the belt tensioning device A (see fig. 73).
2. Also completely unscrew the belt tensioning screws B and remove the belt tensioning devices A from their housings.
3. Lift the toothed belt until the guide rails can be seen.
Important: Ensure that the side seal is not damaged.
4. Clean the rail raceways with a clean and dry cloth. Ensure that all grease and dirt residues from previous work processes are removed.
To ensure that the rails are cleaned over their entire length, the slider plate should be moved once over its entire length.
5. Apply a sufficient amount of grease to the raceways.

6. Re-insert the belt tensioning devices A into their housings and mount the belt tensioning screws B. Re-adjust the belt tension (see pg. US-63).
7. Fasten the safety screws C.

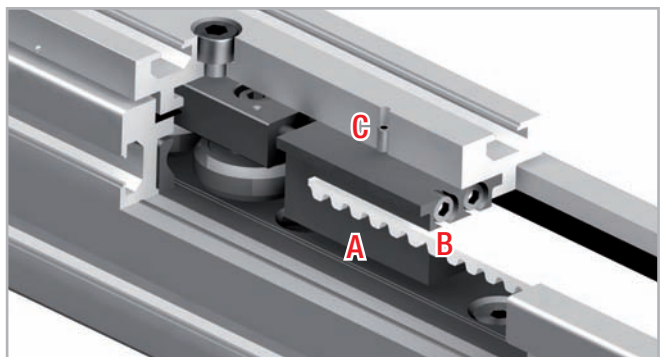

Fig. 73

> Accessories

Adapter plates

Standard motor adapter plates AC2

Mounting plates for the most common motors or gearboxes. The connection bores for the motors or gearboxes must be made on site. All plates are delivered with M6 x 10 screws to DIN 912 and T-nuts for mounting on the linear units.

* Area of plate needs to be cut if used for ED75 linear unit. (Adding 20 mm to total length of unit will render this modification unnecessary). Otherwise it gets in contact with the outer rail.
X = 20 mm; Y = 35 mm

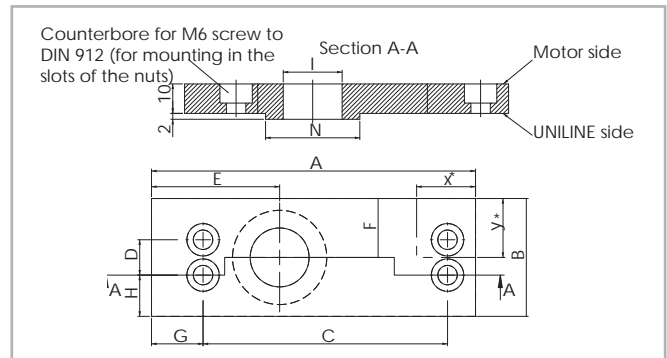

Fig. 74

Size	A [mm]	B [mm]	C [mm]	D [mm]	E [mm]	F [mm]	G [mm]	H [mm]	I [mm]	N [mm]
75	135	70	106	35	53.5	35	19	17.5	∅ 35	∅ 55

Tab. 93

NEMA plates AC1-P

Mounting plates for NEMA motors or gearboxes. These plates are delivered ready-to-mount on the linear axes. All plates are delivered with M6 x 10 screws to DIN 912 and T-nuts for mounting on the linear units.

Size	NEMA Motors / Gearboxes
75	NEMA 42

Tab. 94

* Area of plate needs to be cut if used for ED75 linear unit. (Adding 20 mm to total length of unit will render this modification unnecessary). Otherwise it gets in contact with the outer rail.
X = 20 mm; Y = 60 mm

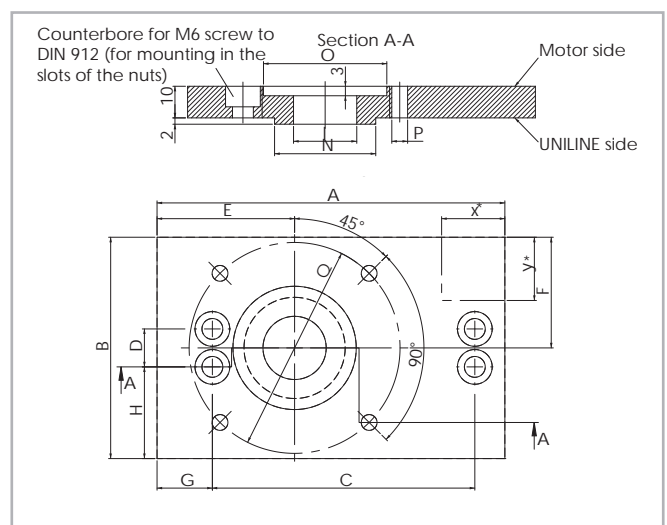

Fig. 75

Size	A [mm]	B [mm]	C [mm]	D [mm]	E [mm]	F [mm]	G [mm]	H [mm]	I [mm]	N [mm]	O [mm]	P [mm]	Q [mm]
75	135	120	106	35	53.5	60	19	42.5	35	∅ 55	∅ 57	∅ 7.1	∅ 125.7

Tab. 95

Synchronous use of linear axes in pairs

If two axes are to be used in parallel using a connecting shaft, please specify when ordering, to ensure that the key slots of the pulleys are synchronized.

Fixing brackets APF-2

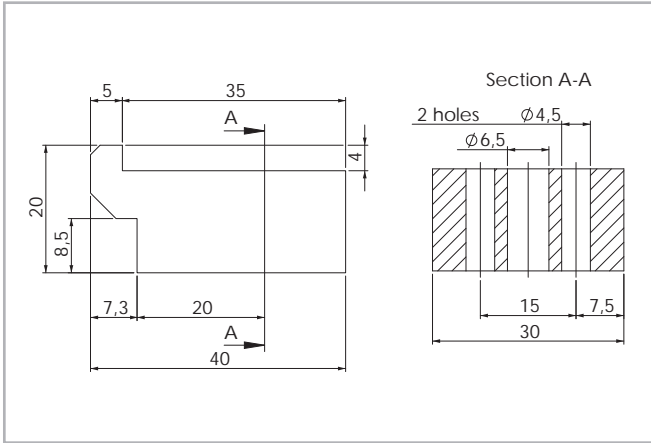

Fig. 76

Fixing clamp for simple mounting of a linear axis on a mounting surface or for connecting two units with or without a connection plate (see pg. US-68).

A spacer* may be necessary.

*(Any spacer that may be necessary must be manufactured on site)

T-nut

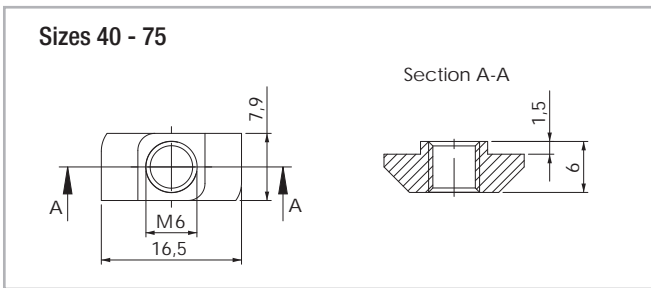

Fig. 77

The maximum tightening torque is 10 Nm.

Assembly kits

T-connection plate APC-1

T-connection plate allows two units to be mounted perpendicular to each other (see pg. US-65). The plate will not interfere with the strokes of either unit. All plates are delivered with M6 x 10 screws to DIN 912 and T-nuts for mounting on the linear units.

Note

This adapter plate can be used with types E and ED only to a limited extent. For further information, please contact our Application Engineering Department.

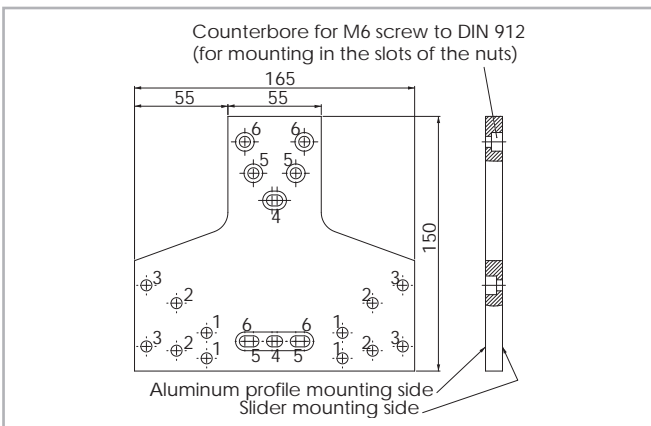

Fig. 78

Size	Fixing holes for the slider	Fixing holes for the profile
75	Holes 3	Holes 6

Tab. 96

Angle connection plate APC-2

allows the right angle mounting of two units. The trolley of one unit can be mounted to the side of the other (see pg. US-66). The plate will not interfere with the strokes of either unit. All plates are delivered with M6 x 10 screws to DIN 912 and T-nuts for mounting to the linear units.

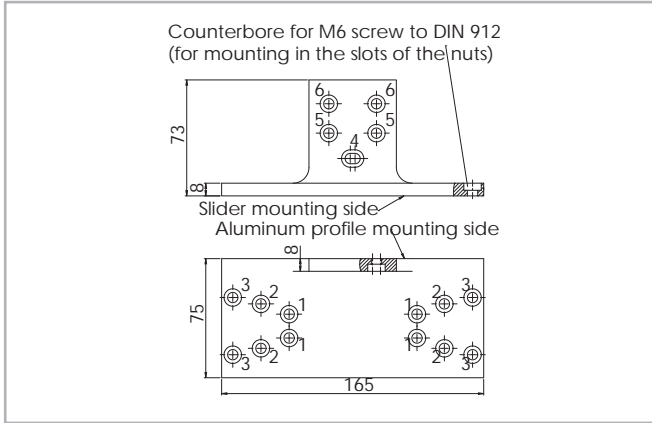

Fig. 79

Note

This adapter plate can be used with types E and ED only to a limited extent. For further information, please contact our Application Engineering Department.

Size	Fixing holes for the slider	Fixing holes for the profile
75	Holes 3	Holes 6

Tab. 97

X connection plate APC-3

X connection plate for mounting two sliders perpendicular to each other (see pg. US-67). The plate will not interfere with the strokes of either unit. All plates are delivered with M6 x 10 screws to DIN 912 and T-nuts for mounting on the linear units.

Size	Fixing holes for slider 1	Fixing holes for slider 2
75	Holes 3	Holes 6

Tab. 98

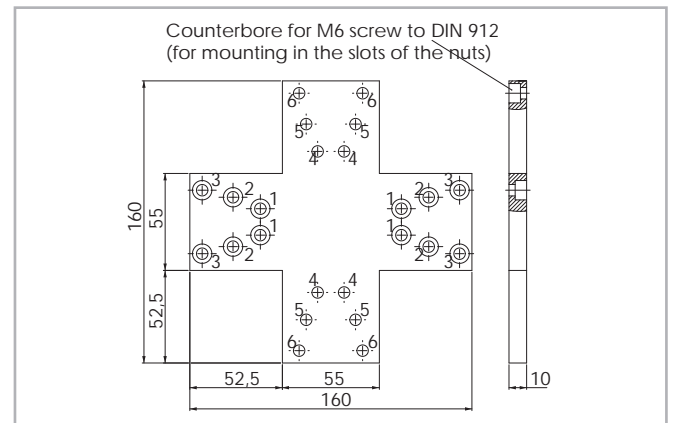

Fig. 80

Ordering key 

> Identification code for Uniline linear unit

U	D	07 07=75	1A	1190	1A	D 500	L 350
						Indices of long slider plate <i>see pg. US-46</i>	
						Indices of double slider plate, <i>distance of the centers of slider plates</i> <i>see pg. US-46</i>	
						Profile/Rail code	
						L= Total length of the unit	
						Driving head code	
						Size <i>see pg. US-46</i>	
						Type	
						Uniline prefix	

Ordering example: UD 07 1A 1190 1A D 500 L 350

In order to create identification codes for Actuator Line, you can visit: <http://configureactuator.rollon.com>

> Accessories

Standard motor adapter plate

D	07	AC2	
	07=75	Standard motor adapter plates	see pg. US-49
	Size	see pg. US-49	
Type			

Ordering example: D07-AC2

NEMA motor adapter plates

D	07	AC1	
	07=75	NEMA motor adapter plates	see pg. US-49
	Size	see pg. US-49	
Type			

Ordering example: D07-AC1

T-connection plate Order code: APC-1, s. pg. US-50

Angle connection plate Order code: APC-2, s. pg. US-51

X connection plate Order code: APC-3, s. pg. US-51

Fixing clamp Order code: APF-2, s. pg. US-50

Motor connection bores

Hole [Ø]	Size	Head code
	75	
Metric [mm] with slot for key	14G8 / 5js9	1A
	16G8 / 5js9	2A
	19G8 / 6js9	3A
		4A
Metric [mm] for compression coupling	18	1B
	24	2B
Inch [in] with slot for key	5/8 / 3/16	1P
		2P
		3P

Tab. 99

The highlighted connection bores are standard connections

Metric: key seat for keys to DIN 6885 form A

Inch: key seat for keys to BS 46 Part 1: 1958

Uniline H series



> Uniline H series description



Fig. 81

Uniline is a family of ready-to-install linear actuators. They consist of internal Compact Rail roller sliders in a rigid aluminum profile. Longitudinal seals enclose the system. This arrangement provides the best protection for the actuator from soiling and damage. In the H series, the compensating bearing rail (U-rail) is mounted horizontally in the aluminum profile. The H series is used as a compensating bearing axis for load absorption of radial forces, and in combination with the other series, as support bearing for the resulting moments. Versions with long (L) or double (D) sliders in one axis are possible. H series is a slave actuator, it has not the driving belt.

The most important characteristics:

- Compact design
- Protected internal linear guides
- High traversing speeds
- Grease-free operation possible (depending on the application. For further information, please contact our Application Engineering department)
- High versatility
- Long strokes
- Versions with long or multiple sliders available in one linear axis

Preferred areas of application:

- Handling and automation
- Multi-axis gantries
- Packaging machines
- Cutting machines
- Displaceable panels
- Painting installations
- Welding robots
- Special machines

Technical data:

- Available sizes [mm]:
Type H: 40, 55, 75
- Length and stroke tolerances:
For strokes <1 m: +0 mm to +10 mm (+0 in to 0.4 in)
For strokes >1 m: +0 mm to +15 mm (+0 in to 0.59 in)

> The components

Extruded profile

The anodized 6060 aluminum alloy extrusion used for the profile of the Rollon Uniline series linear units were designed and manufactured by industry experts to optimize weight while maintaining mechanical strength. (see physical-chemical characteristics below). The dimensional tolerances comply with EN 755-9 standard.

Carriage

The carriage of the Rollon Uniline H series linear units are made entirely of anodized aluminum. Each carriage has mounting T-slots for the connection to the moving element. Rollon offers multiple carriages to accommodate a vast array of applications.

General data about aluminum used: AL 6060

Chemical composition [%]

Al	Mg	Si	Fe	Mn	Zn	Cu	Impurites
Remainder	0.35-0.60	0.30-0.60	0.30	0.10	0.10	0.10	0.05-0.15

Tab. 100

Physical characteristics

Density	Coeff. of elasticity	Coeff. of thermal expansion (20°-100°C)	Thermal conductivity (20°C)	Specific heat (0°-100°C)	Resistivity	Melting point
$\frac{\text{kg}}{\text{dm}^3}$	$\frac{\text{kN}}{\text{mm}^2}$	$\frac{10^{-6}}{\text{K}}$	$\frac{\text{W}}{\text{m} \cdot \text{K}}$	$\frac{\text{J}}{\text{kg} \cdot \text{K}}$	$\Omega \cdot \text{m} \cdot 10^{-9}$	°C
2.7	69	23	200	880-900	33	600-655

Tab. 101

Mechanical characteristics

Rm	Rp (02)	A	HB
$\frac{\text{N}}{\text{mm}^2}$	$\frac{\text{N}}{\text{mm}^2}$	%	—
205	165	10	60-80

Tab. 102

> H40

H40 system

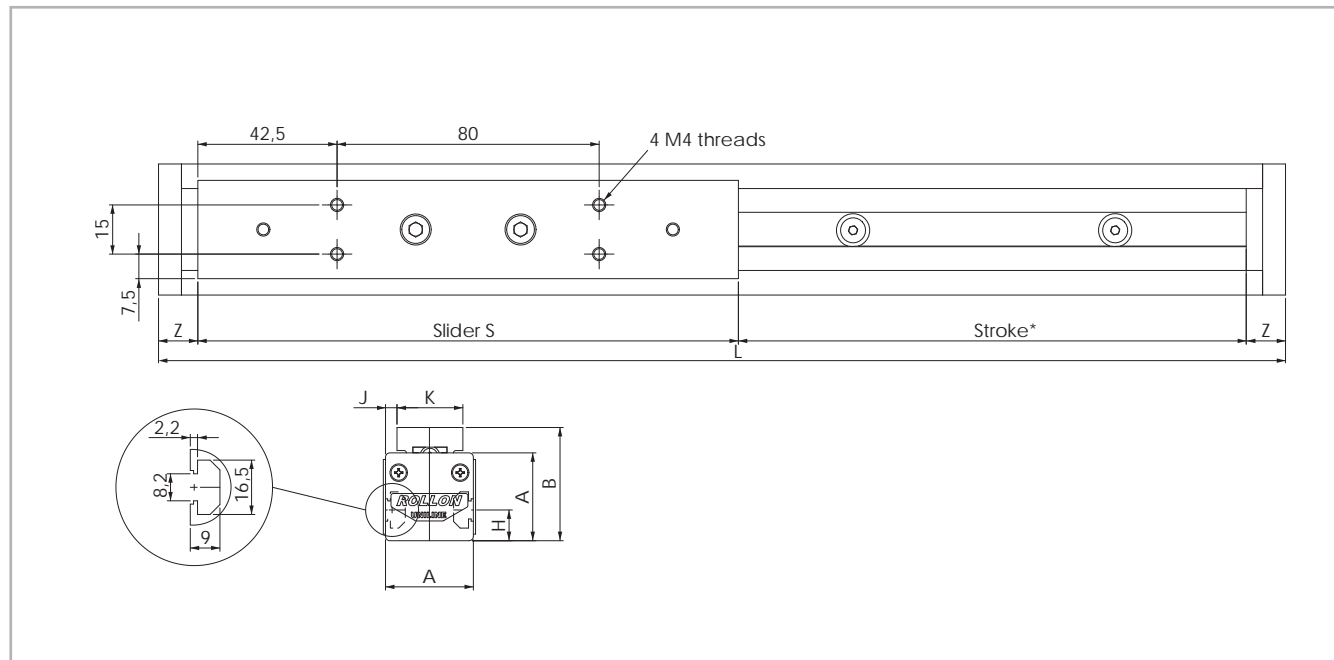

* The length of the safety stroke is provided on request according to the customer's specific requirements.

Fig. 82

Type*	A [mm]	B _{nom} [mm]	B _{min} [mm]	B _{max} [mm]	D [mm]	H [mm]	J [mm]	K [mm]	S [mm]	X [mm]	Y [mm]	Z [mm]	Stroke** [mm]
H40	40	51.5	51.2	52.6	-	14	5	30	165	-	-	12	1900

* Including long or double slider. See chapter 3 Product dimensions Types A...L and A...D

** Maximum stroke for a single-piece guiding rail. For longer strokes, see tab. 105

Tab. 103

H40

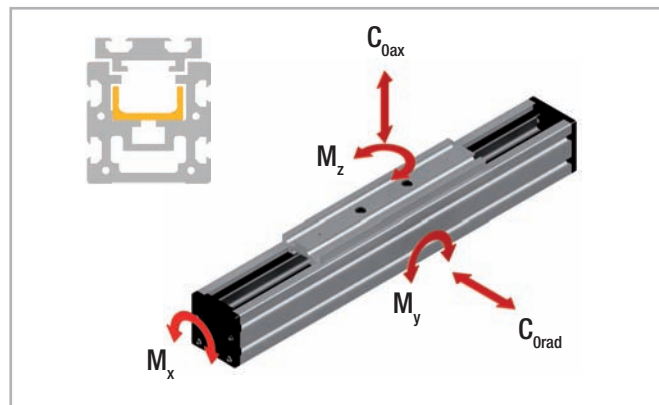

Fig. 83

Type	C [N]	C _{0rad} [N]	C _{0ax} [N]	M _x [Nm]	M _y [Nm]	M _z [Nm]
H40	1530	820				13.1
H40-L	3060	1640	0	0	0	61 to 192
H40-D	3060	1640				192 to 1558

For the calculation of the allowed moments, please see pages SL-5ff

Tab. 104

Technical data	Type
	H40
Max. traversing speed [m/s]	3
Max. acceleration [m/s ²]	10
Repeat accuracy [mm]	0.1
Linear accuracy [mm]	0.8
Compact Rail guiding rail	ULV18
Slider type	CS18 spec.
Moment of inertia I _y [cm ⁴]	12
Moment of inertia I _z [cm ⁴]	13.6
Mass of slider [g]	220
Weight with zero stroke [g]	860
Weight with 1 m stroke [g]	3383
Max. stroke [mm]	3500
Working temperature	from -20 °C to + 80 °C

Tab. 105

> H55

H55 system

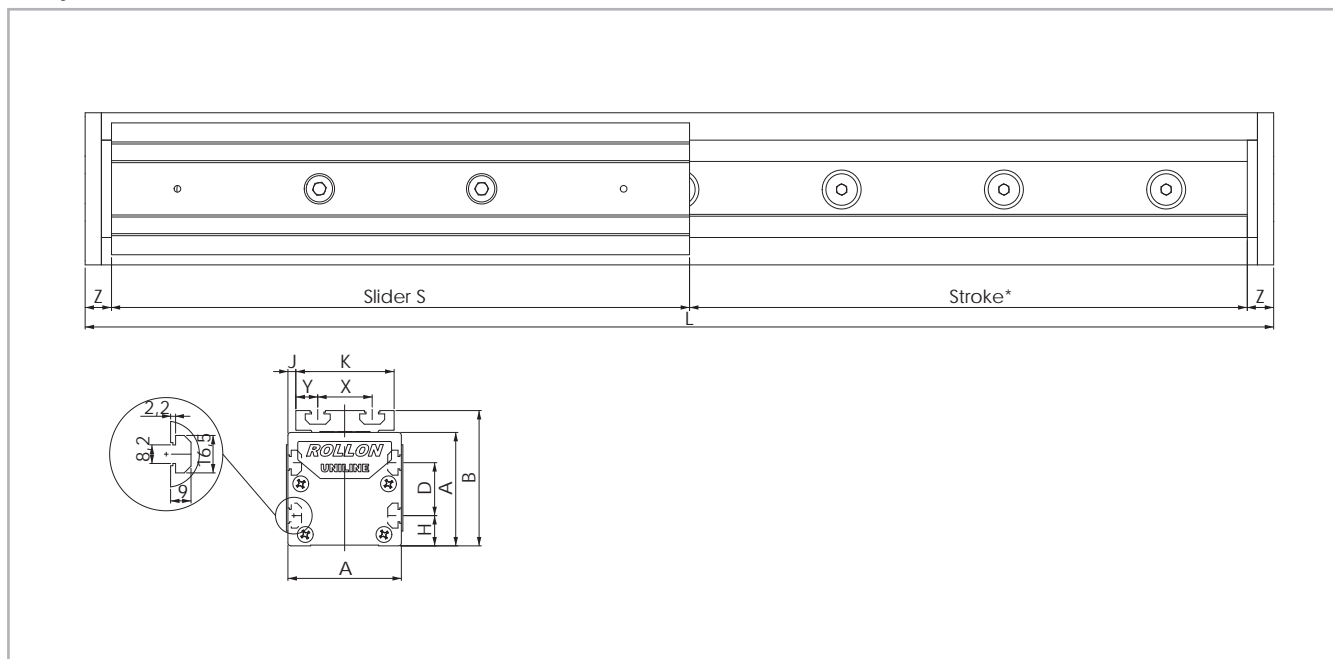

* The length of the safety stroke is provided on request according to the customer's specific requirements.

Fig. 84

Type*	A [mm]	B _{nom} [mm]	B _{min} [mm]	B _{max} [mm]	D [mm]	H [mm]	J [mm]	K [mm]	S [mm]	X [mm]	Y [mm]	Z [mm]	Stroke** [mm]
H55	55	71	70.4	72.3	25	15	1.5	52	200	28	12	13	3070

* Including long or double slider. See chapter 3 Product dimensions Types A...L and A...D

** Maximum stroke for a single-piece guiding rail. For longer strokes, see tab. 108

Tab. 106

H55

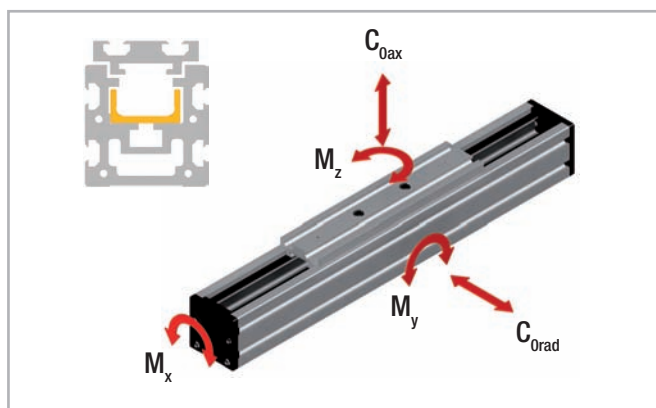

Fig. 85

Type	C [N]	C _{0rad} [N]	C _{0ax} [N]	M _x [Nm]	M _y [Nm]	M _z [Nm]
H55	4260	2175				54.5
H55-L	8520	4350	0	0	0	239 to 652
H55-D	8520	4350				652 to 6677

For the calculation of the allowed moments, please see pages SL-5ff

Tab. 107

Technical data	Type
	H55
Max. traversing speed [m/s]	5
Max. acceleration [m/s ²]	15
Repeat accuracy [mm]	0.1
Linear accuracy [mm]	0.8
Compact Rail guiding rail	ULV28
Slider type	CS28 spec.
Moment of inertia I _y [cm ⁴]	34.6
Moment of inertia I _z [cm ⁴]	41.7
Mass of slider [g]	475
Weight with zero stroke [g]	1460
Weight with 1 m stroke [g]	4357
Max. stroke [mm]	5500
Working temperature	from -20 °C to + 80 °C

Tab. 108

> H75

H75 system

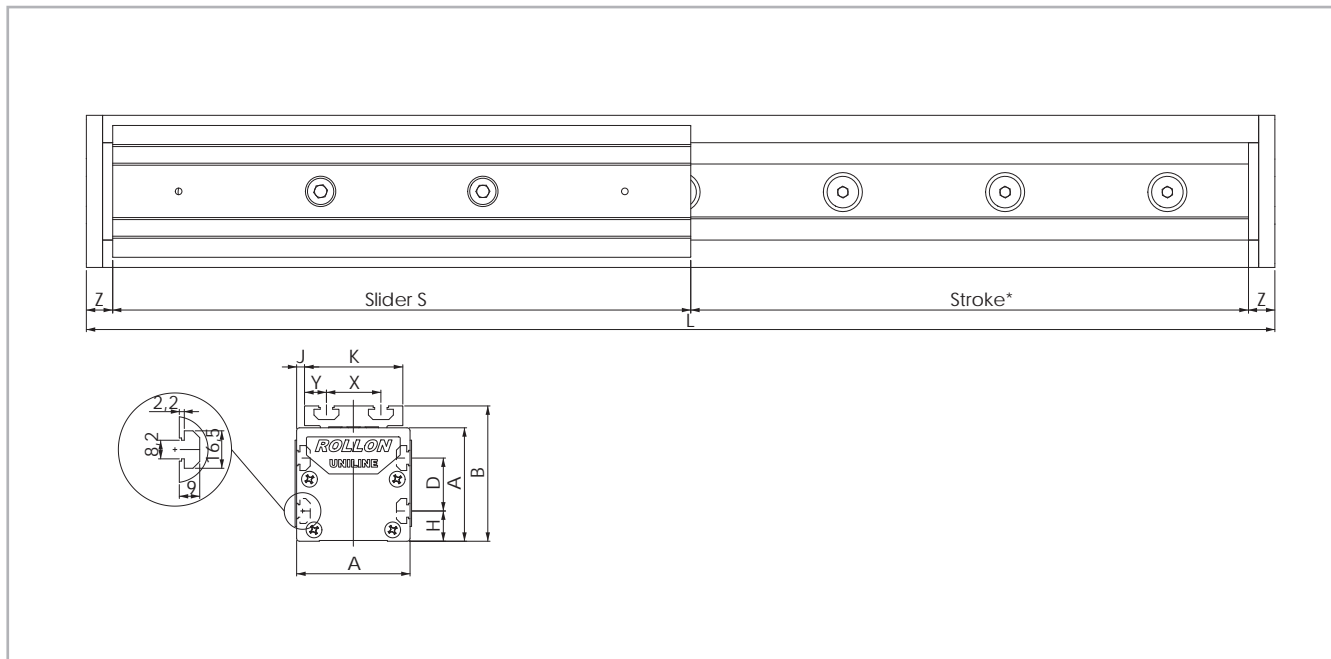

* The length of the safety stroke is provided on request according to the customer's specific requirements.

Fig. 86

Type*	A [mm]	B _{nom} [mm]	B _{min} [mm]	B _{max} [mm]	D [mm]	H [mm]	J [mm]	K [mm]	S [mm]	X [mm]	Y [mm]	Z [mm]	Stroke** [mm]
H75	75	90	88.6	92.5	35	20	5	65	285	36	14.5	13	3420

* Including long or double slider. See chapter 3 Product dimensions Types A...L and A...D

** Maximum stroke for a single-piece guiding rail. For longer strokes, see tab. 111

Tab. 109

H75

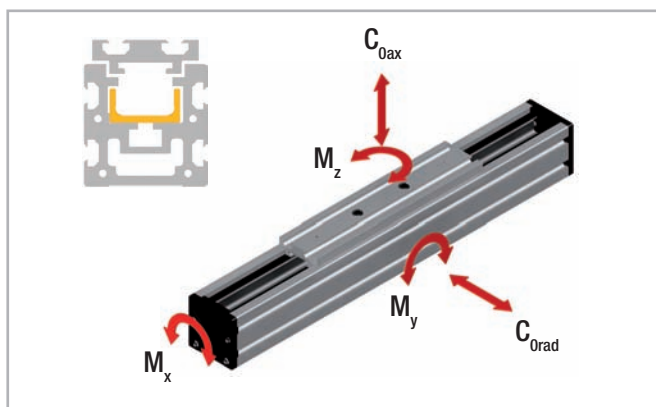

Fig. 87

Type	C [N]	C _{0rad} [N]	C _{0ax} [N]	M _x [Nm]	M _y [Nm]	M _z [Nm]
H75	12280	5500				209
H75-L	24560	11000	0	0	0	852 to 2282
H75-D	24560	11000				2288 to 18788

For the calculation of the allowed moments, please see pages SL-5ff

Tab. 110

Technical data	Type
	H75
Max. traversing speed [m/s]	7
Max. acceleration [m/s ²]	15
Repeat accuracy [mm]	0.1
Linear accuracy [mm]	0.8
Compact Rail guiding rail	ULV43
Slider type	CS43 spec.
Moment of inertia I _y [cm ⁴]	127
Moment of inertia I _z [cm ⁴]	172
Mass of slider [g]	1242
Weight with zero stroke [g]	4160
Weight with 1 m stroke [g]	9381
Max. stroke [mm]	7500
Working temperature	from -20 °C to + 80 °C

Tab. 111

> Lubrication

The raceways of the guide rails in the Uniline linear axes are prelubricated. To achieve the calculated service life, a lubrication film must always be present between the raceway and the roller. The lubrication film also provides anticorrosion protection to the ground raceways. An approximate value for the lubrication period is every 100 km or every six months. The recommended lubricant is a lithium-based roller bearing grease of medium consistency.

Lubrication of the raceways

Proper lubrication under normal conditions:

- reduces friction
- reduces wear
- reduces stress on the contact faces
- reduces running noise

Lubricants	Thickeners	Temperature range [°C]	Dynamic viscosity [mPas]
Roller bearing grease	Lithium soap	-30 to +170	<4500

Tab. 112

Relubrication of the guide rails

These types of rails have a lubricating conduit on the side of the slider plate through which the lubricant can be applied directly to the raceways. Lubrication can be done in one of two ways:

1. Relubrication using a grease gun:

This is done by inserting the tip of the grease gun into the conduit at the slider plate and injecting the grease inside (see fig. 88). Please note that the grease has to fill the whole conduit in order to lubricate the rail properly; for this reason sufficient grease must be used.

2. Automatic lubrication system:

To connect the unit to an automatic greasing system, use a proper adapter/connector* that attaches to the threaded hole on the side of the trolley.

The advantage of this solution is the possibility of rail re-lubrication without machine downtime.

*(Any adapter that may be necessary must be manufactured on site)

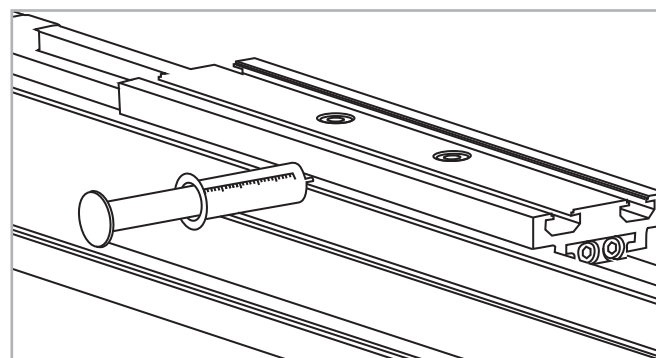

Fig. 88

Cleaning the guide rails

It is always recommended to clean the slider rail prior to any relubrication, in order to remove grease residues. This can be done while performing maintenance work or during a scheduled machine stop.

1. Clean the rail raceways with a clean and dry cloth. Ensure that all grease and dirt residues from previous work processes are removed.

To ensure that the rails are cleaned over their entire length, the slider plate should be moved once over its entire length.

2. Apply a sufficient amount of grease to the raceways.

> Accessories

Fixing brackets APF-2

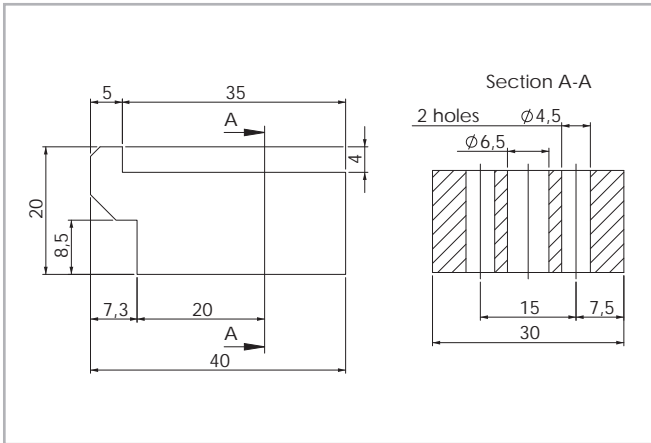

Fig. 89

Fixing clamp for simple mounting of a linear axis on a mounting surface or for connecting two units with or without a connection plate (see pg. US-68).

A spacer* may be necessary.

*(Any spacer that may be necessary must be manufactured on site)

T-nut

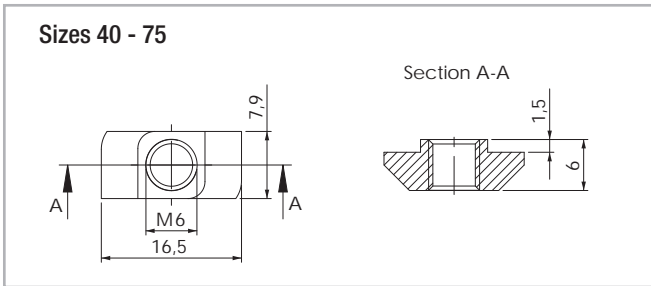

Fig. 90

The maximum tightening torque is 10 Nm.

Assembly kits

T-connection plate APC-1

T-connection plate allows two units to be mounted perpendicular to each other (see pg. US-65). The plate will not interfere with the strokes of either unit. All plates are delivered with M6 x 10 screws to DIN 912 and T-nuts for mounting on the linear units.

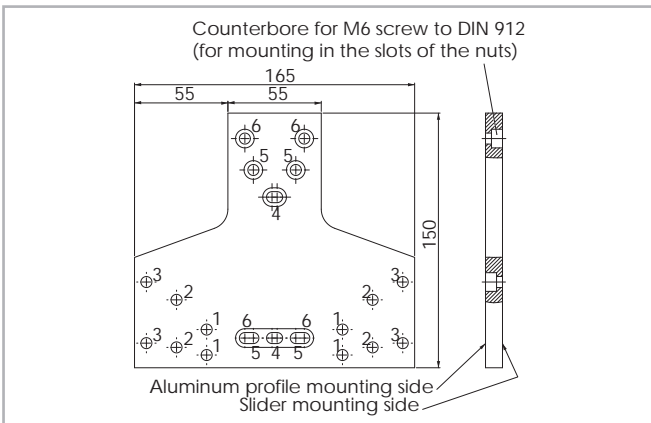

Fig. 91

Size	Fixing holes for the slider	Fixing holes for the profile
40	Holes 1	Holes 4
55	Holes 2	Holes 5
75	Holes 3	Holes 6

Tab. 113

Angle connection plate APC-2

allows the right angle mounting of two units. The trolley of one unit can be mounted to the side of the other (see pg. US-66). The plate will not interfere with the strokes of either unit. All plates are delivered with M6 x 10 screws to DIN 912 and T-nuts for mounting to the linear units.

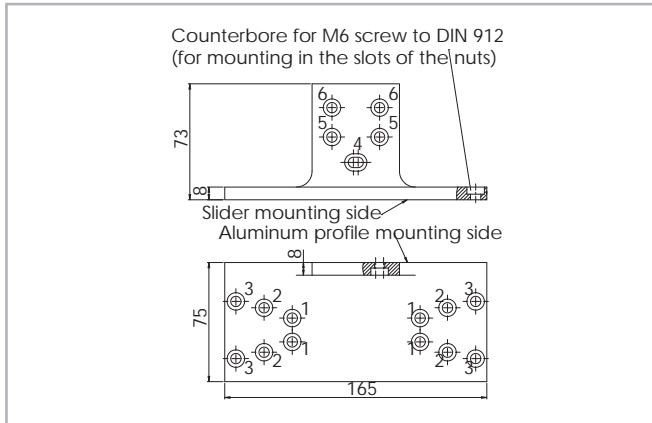

Fig. 92

Size	Fixing holes for the slider	Fixing holes for the profile
40	Holes 1	Holes 4
55	Holes 2	Holes 5
75	Holes 3	Holes 6

Tab. 114

X connection plate APC-3

X connection plate for mounting two sliders perpendicular to each other (see pg. US-67). The plate will not interfere with the strokes of either unit. All plates are delivered with M6 x 10 screws to DIN 912 and T-nuts for mounting on the linear units.

Size	Fixing holes for slider 1	Fixing holes for slider 2
40	Holes 1	Holes 4
55	Holes 2	Holes 5
75	Holes 3	Holes 6

Tab. 115

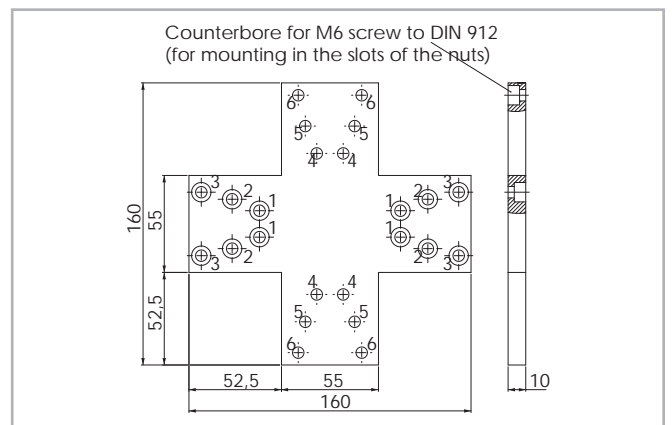

Fig. 93

Ordering key

> Identification code for Uniline linear unit

U	H	07	1H	1190	1A	D 500	L 350
		04=40					
		05=55					
		07=75					
							Indices of long slider plate <i>see pg. US-56 - US-57 - US-58</i>
							Indices of double slider plate, <i>distance of the centers of slider plates</i> <i>see pg. US-56 - US-57 - US-58</i>
							Profile/Rail code
							L= Total length of the unit
							Driving head code
							Size <i>see pg. US-56 - US-57 - US-58</i>
							Type
							Uniline prefix

Ordering example: UH 07 1H 1190 1A D 500 L 350

In order to create identification codes for Actuator Line, you can visit: <http://configureactuator.rollon.com>

Belt tension

All Uniline linear axes are all supplied with a standard belt tension suitable for most applications (see tab. 116).

Size	40	55	75	ED75	100
Belt tension [N]	160	220	800	1000	1000

Tab. 116

The belt tensioning system (located at the ends of the slider plates for sizes 45 to 75, and at the deflection head for size 100) allows the toothed belt tension to be set in accordance with requirements.

To set the belt tension for sizes 40 to 75, the following steps must be followed (the reference values are standard values):

1. Determine the deviation of the belt tension from the standard value.
2. Figures 95 and 96 show how many turns the belt tensioning screws B must be for the required belt tension deviation.
3. Calculate the length of the belt (m), with the formula:
 - $L = 2 \times \text{stroke (m)} + 0.515 \text{ m (size 40)}$;
 - $L = 2 \times \text{stroke (m)} + 0.630 \text{ m (size 55)}$;
 - $L = 2 \times \text{stroke (m)} + 0.792 \text{ m (size 75)}$.
4. Multiply the number of turns (see step 2) by the toothed belt length m (see step 3) to calculate the required number of turns to achieve the new desired belt tension..
5. Unscrew the safety screw C.
6. Turn the belt tensioning screws B in accordance with the above explanation. Re-tighten the safety screw C.

Example:

Increasing the belt tension from 220 N to 330 N for an A55 - 1070:

1. deviation = 330 N - 220 N = 110 N.
2. Figures 95 and 96 show that the value by which the belt tensioning screws B must be turned to increase the belt tension by 110 N is 0.5 turns.
3. Formula for calculating the toothed belt length:
 - $L = 2 \times \text{stroke (m)} + 0.630 \text{ m} = 2 \times 1.070 + 0.630 = 2.77 \text{ m}$.

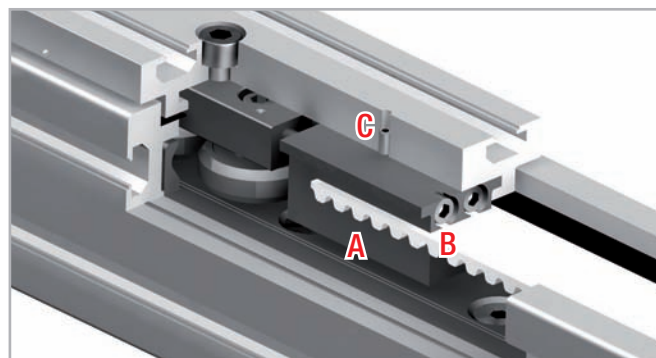

Fig. 94

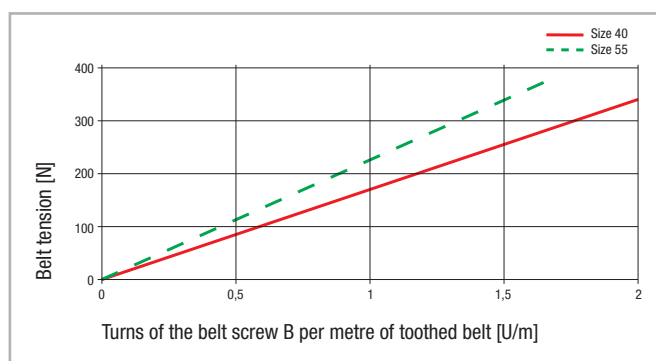

Fig. 95

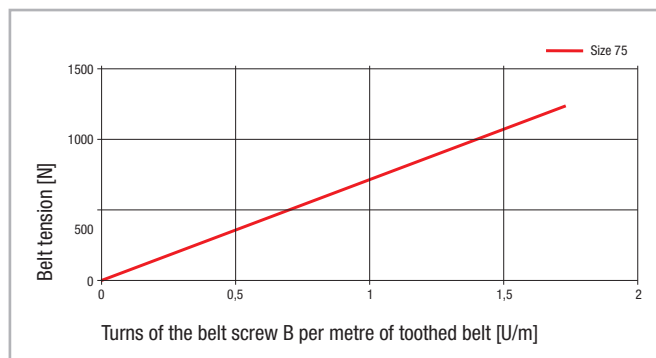

Fig. 96

4. This means that the required number of turns is:
 - $0.5 \text{ rpm} \times 2.77 \text{ m} = 1.4 \text{ turns}$.
5. Unscrew the safety screw C.
6. Turn the belt tensioning screws B by 1.4 turns with the aid of an external reference.
7. Re-tighten the safety screw C.

To set the belt tension for size 100, the following steps must be followed (the reference values are standard values):

1. Determine the deviation of the belt tension from the standard value.
2. Figure 97 shows how far the belt deflection pulley must be offset at the deflection head via the set screws A, in order to obtain the desired belt tension.
3. Multiply the offset by the stroke length.
4. Turn the set screws A in accordance with the above explanation.

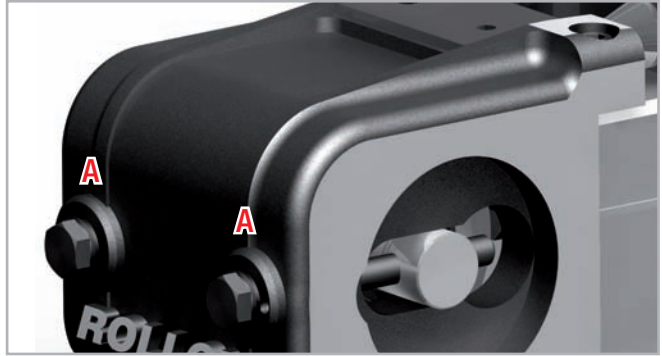

Fig. 97

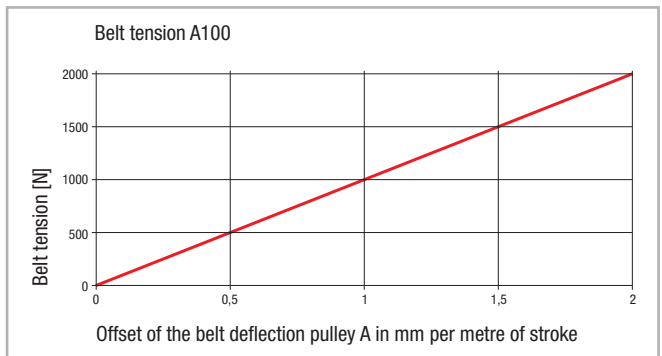

Fig. 98

Example:

Increasing the belt tension from 1000 N auf 1500 N for an A100-2000:

1. Deviation = 1500 N - 1000 N = 500 N.
2. The graphic shows that the offset of the belt deflection pulley required for increasing the belt tension by 500 N is 0.5 mm per metre of stroke.
Offset = 0.5 mm x 2 (stroke) = 1 mm

Note:

If the linear unit is used such that the load acts directly on the toothed belt, it is important not to exceed the specified values for the belt tension. Otherwise, the positional accuracy and stability of the toothed belt cannot be guaranteed. If higher values are required for the belt tension, please contact our Application Engineering Department.

Installation instructions



Motor adapter plates AC2 and AC1-P, sizes 40 - 75

To connect the linear units to the motor and gearbox, suitable adapter plates must be used. Rollon offers these plates in two different designs (see chapter Accessories), except for size A100. The standard plates are already provided with the holes required for mounting to the linear unit. The fixing holes must be made on site. Ensure that the mounted plate will not interfere with the stroke of the traversing slider plate.

Connection to motor and gearbox

1. Attach the motor adapter plate to the motor or gearbox.
2. Connect the T-nuts by inserting the screws without tightening them and align the nuts in parallel to the slots of the unit.
3. Insert the connecting shaft into the drive head by aligning the key in the key slot.
4. Attach the motor adapter plate to the drive head of the linear axis by means of nuts and make sure that the nuts in the slots were rotated by 90° (see Accessories). Ensure correct fit of the adapter plate.

T-connection plate APC-1, sizes 40 - 75

Connection of two linear axes is achieved by means of the T-connection plate APC-1 (see chapter Accessories). To mount the above-mentioned configuration, the following steps should be carried out:

1. Prepare the connection plate by inserting the screws into the existing holes on the APC-1 (see fig. 100).
2. Connect the T-nuts by introducing the screws without tightening them and align the nuts in parallel to the slots of the unit.
3. Place the plate against the long side of unit 1 and tighten the screws. Ensure that the nuts in the slots were rotated by 90°.
4. To fasten the plate to unit 2, insert the screws from the the long side of unit 1 (see fig. 101).
5. Connect the T-nuts by introducing the screws without tightening them and align the nuts in parallel to the slots of the slider plate of unit 2.
6. Place the plate against the slider plate and tighten the screws. Important: Please make sure that the nuts in the slots were rotated by 90°.

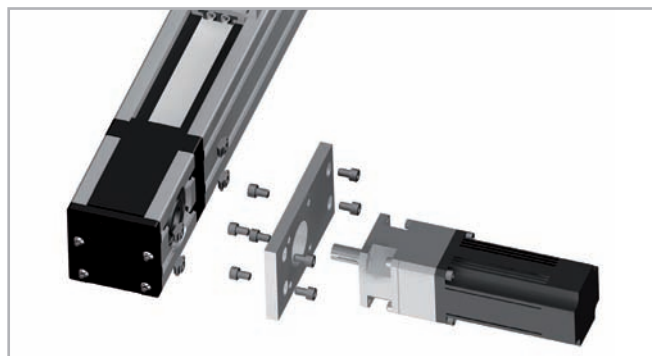

Fig. 99

Note:

- The connecting plates for the Uniline A40 are delivered with four fixing holes, even though only two holes are required for the connection. The presence of four holes give the plate a symmetric design which allows it to be used on any side of the unit.
- Due to the constructive design of the aluminum profile, only three fixing holes can be used for the Uniline C series. (see pg. US-22, fig. 32).

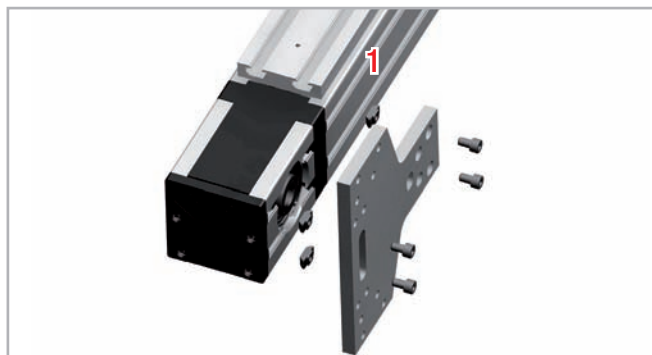

Fig. 100



Fig. 101

Example 1: System consisting of 2 X-axes and 1 Y-axis

The connection of the two units is attained by means of the parallel slider plates and the drive heads. For this configuration, we recommend using our connection plate APC-1.



Fig. 102

Angle connection plate APC-2, sizes 40 - 75

Connection of two linear axes is achieved by means of the angle connection plate APC-2. To mount the above-mentioned configuration, the following steps should be carried out:

1. Insert the screws to be used for the connection to unit 1 into the prepared holes (see fig. 103).
2. Connect the T-nuts by inserting the screws without tightening them and align the nuts in parallel to the slots of the slider plates.
3. Place the connection plate against the slider plate and tighten the screws. Ensure that the nuts in the slots were rotated by 90°.
4. To fix the connection plate to unit 2, insert the screws into the prepared holes on the short plate side (see fig. 104).
5. Connect the T-nuts by inserting the screws without tightening them and align the nuts in parallel to the slots of the aluminum profile of unit 2.
6. Place the connection plate against the slider plate and tighten the screws. Ensure that the nuts in the slots were rotated by 90°.

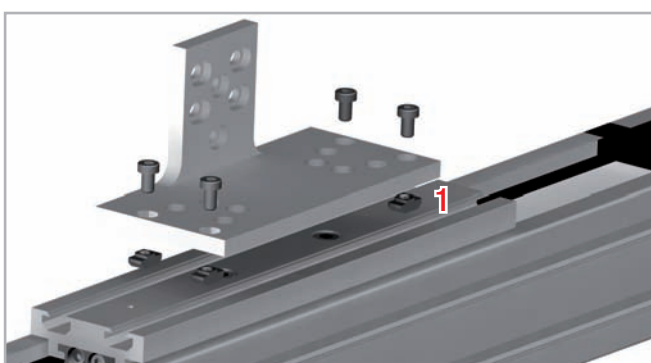

Fig. 103

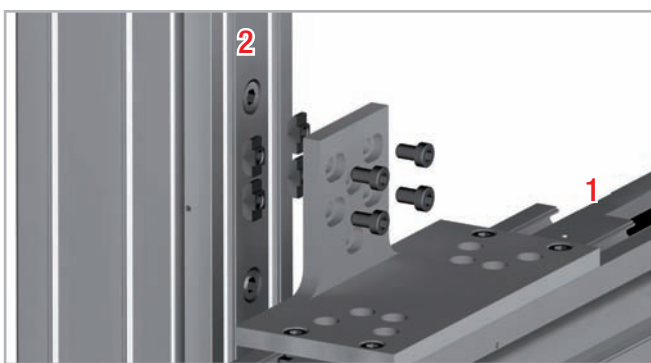

Fig. 104

Example 2 – System consisting of 1 X-axis and 1 Z-axis

With this configuration, the Z-axis is connected to the slider plate of the X-axis by means of the angle connection plate APC-2.



Fig. 105

X connection plate APC-3, sizes 40 - 75

Connection of the two linear axes is achieved by means of the X connection plate APC-3 (see chapter Accessories). To mount the above-mentioned configuration, the following steps should be carried out:

1. Insert the screws from one side of the connection plate into the prepared holes (see fig. 106).
2. Connect the T-nuts by inserting the screws without tightening them and align the nuts in parallel to the slots of the slider plate of unit 1.
3. Place the connection plate against the slider plate and tighten the screws. Ensure that the nuts in the slots were rotated by 90°.
4. Insert the screws from the other side of the connection plate (see fig. 107).
5. Connect the T-nuts by inserting the screws without tightening them and align the nuts in parallel to the slots of the slider plate of unit 2.
6. Place the connection plate against the slider plate and tighten the screws. Ensure that the nuts in the slots were rotated by 90°.

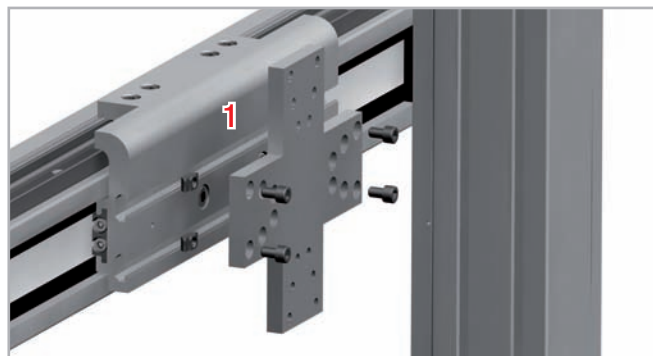

Fig. 106

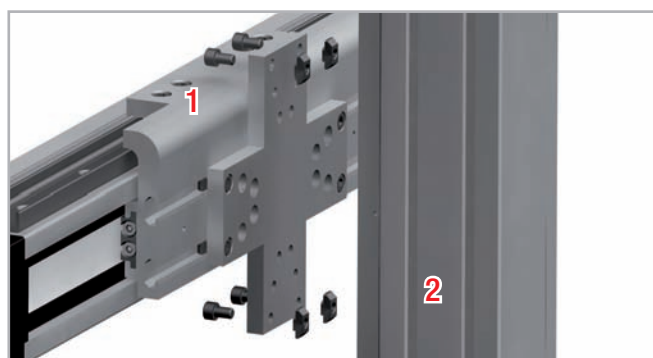

Fig. 107

Example 3 – System consisting of 2 X-axes, 1 Y-axis and 1 Z-axis

Connect four linear units to create a 3-axis gantry. The vertical axis is arranged to be self-supporting on the central unit. To do so, connect the two slider plates to each other, using the X connection plate APC-3.

The connection of the two parallel axes to the central unit is attained by means of the T-connection plate APC-1.

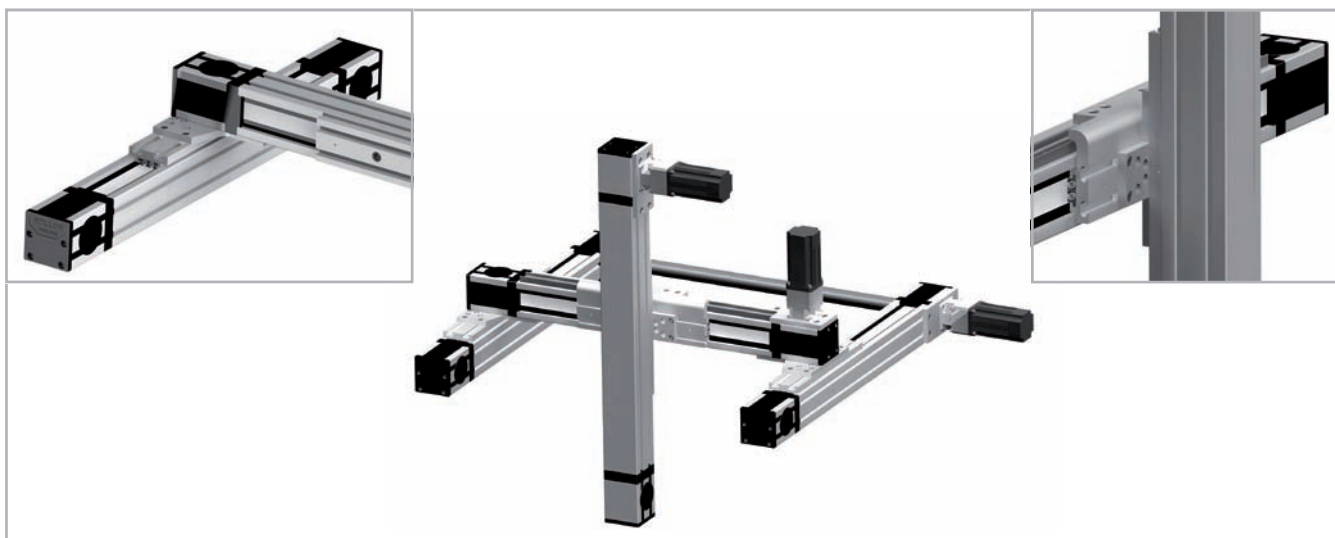

Fig. 108

Fixing clamp APF-2, sizes 40 - 75

Connection of two linear axes is achieved by means of the fixing clamps APF-2 (see chapter Accessories). To mount the above-mentioned configuration, the following steps should be carried out:

1. Insert the fastening screws into the clamp and, if necessary, place a spacer* between the clamp and the slider plate.
*(Any spacer that is to be used must be manufactured on site)
2. Connect the T-nuts by inserting the screws without tightening them and align the nuts in parallel to the slots of the slider plates.
3. Insert the projecting part of the clamp into the lower slot of the aluminum profile of unit 1.
4. Position the clamp lengthwise according to the desired position of the slider plate of unit 2.

5. Tighten the fastening screws. Ensure that the nuts in the slots were rotated by 90°.
6. Repeat this operation for the required number of fixing clamps.

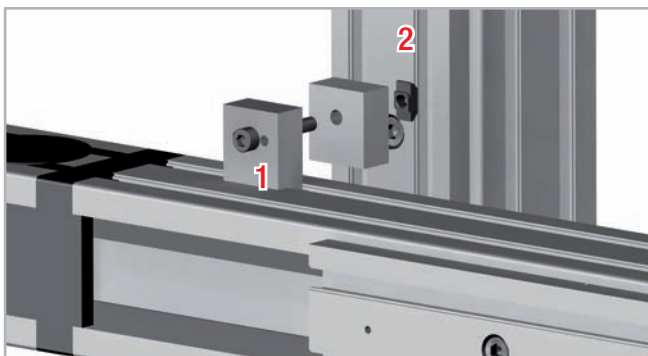

Fig. 109

Example 4 – System consisting of 1 Y-axis and 2 Z-axes

The connection of the Y-axis to the parallel slider plates is attained via the fixing clamps APF-2.

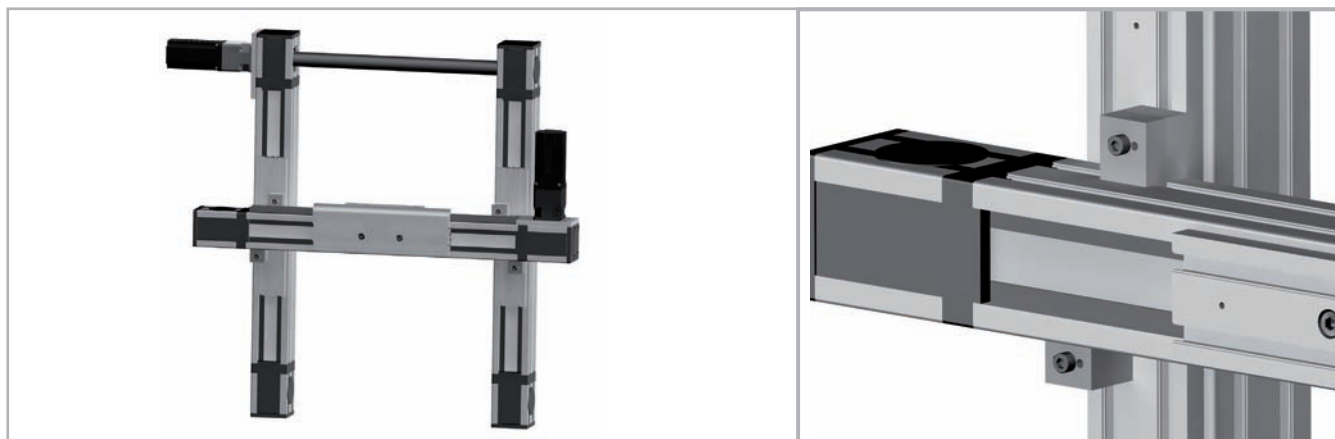

Fig. 110

ROLLON[®]
Linear Evolution

Precision System



TH series



> TH series description



Fig. 1

TH linear actuators are rigid and compact, ball screw driven linear units, that enable high positioning accuracy and repeatability in all process phases. With optimal performance assured, TH actuators have a repeatability within 5 μm .

Thrust force transmission is achieved by means of super high efficient ball screws, which are available in several precision classes and a variety of leads. Linear motion is based on two or four preloaded re-circulating ball bearing blocks, with ball retainer technology, mounted on two precision aligned parallel rails. The TH series is available in single carriage or double carriage versions to meet different load requirements.

The TH linear units also feature safe rail and screw lubrication through a dedicated channel for each component. The incredibly compact structure of the TH actuator makes it the ideal solution for applications where space is limited.

- Extremely compact dimensions
- High positioning accuracy
- High load capacity and stiffness
- Preloaded ball screw
- Block with ball retainer
- Internal protected rails and ball screw
- Safe lubrication through dedicated channels for each component (block and ball screw)

> The components

Aluminum base unit and carriage

The anodized extrusions used for the profile and carriages of the Rollon TH-series linear units were designed and manufactured in cooperation with industry experts to achieve high-level accuracy and to maximize mechanical properties. The anodized aluminum alloy 6060 used and was extruded with dimensional tolerances complying with UNI 3879 standards.

Linear motion system

Precision ball bearing guides with ground rails and preloaded blocks are used on Rollon TH series linear units. Use of this technology makes it possible to obtain the following features:

- High accuracy running parallelism
- High positioning accuracy
- High level of rigidity
- Reduced wear
- Low resistance to movement

Drive system

Rollon TH-series linear units use precision ball screws with either preloaded or non-preloaded ball screw nuts. The standard precision class of the ball screws used is ISO 7, however ISO 5 precision class is also available upon request. The ballscrew on the TH unit is available in different diameters and leads (see specifications tables). Use of this type of technology makes it possible to obtain the following features:

- High speed (for long pitch screws)
- High load capacity and accurate thrust forces
- Superior mechanical performance
- Reduced wear
- Low resistance to movement

Protection

Rollon TH series linear units are equipped with sealing strips in order to protect the mechanical components inside the linear unit against contaminants. In addition, the ball bearing guides and ball screws have their own protection system, including scrapers and lip seals to remove contaminants from the raceways of the ball bearings.

General data about aluminum used: AL 6060

Chemical composition [%]

Al	Mg	Si	Fe	Mn	Zn	Cu	Impurities
Remainder	0.35-0.60	0.30-0.60	0.30	0.10	0.10	0.10	0.05-0.15

Tab. 1

Physical characteristics

Density	Coeff. of elasticity	Coeff. of thermal expansion (20°-100°C)	Thermal conductivity (20°C)	Specific heat (0°-100°C)	Resistivity	Melting point
$\frac{\text{kg}}{\text{dm}^3}$	$\frac{\text{kN}}{\text{mm}^2}$	$\frac{10^{-6}}{\text{K}}$	$\frac{\text{W}}{\text{m} \cdot \text{K}}$	$\frac{\text{J}}{\text{kg} \cdot \text{K}}$	$\Omega \cdot \text{m} \cdot 10^{-9}$	°C
2.7	69	23	200	880-900	33	600-655

Tab. 2

Mechanical characteristics

Rm	Rp (02)	A	HB
$\frac{\text{N}}{\text{mm}^2}$	$\frac{\text{N}}{\text{mm}^2}$	%	—
205	165	10	60-80

Tab. 3

> TH 90 SP2

TH 90 SP2 Dimensions (single carriage)

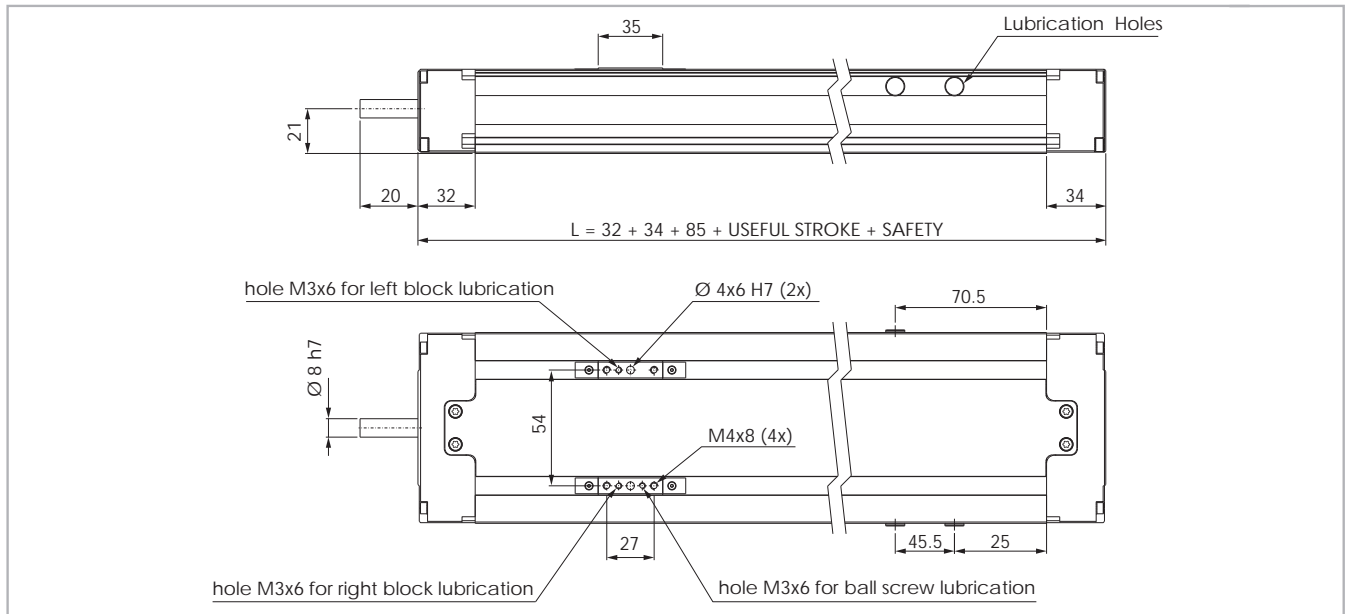

Fig. 2

Technical data

	Type
	TH 90 SP2
Max. useful stroke length [mm]	665
Max. speed [m/s]	See page PS-12
Carriage weight [kg]	0.65
Zero travel weight [kg]	1.41
Weight for 100 mm useful stroke [kg]	0.6

Tab. 4

Moments of inertia of the aluminum body

Type	I_x [10 ⁷ mm ⁴]	I_y [10 ⁷ mm ⁴]	I_p [10 ⁷ mm ⁴]
TH 90 SP2	0.0130	0.0968	0.1098

Tab. 6

Ball screw precision

Type	Max. positioning precision [mm/300mm]		Max. repeatability precision [mm]	
	ISO 5	ISO 7	ISO 5	ISO 7
TH 90 / 12-05	0.023	0.05	0.02	0.02
TH 90 / 12-10	0.023	0.05	0.02	0.02

Tab. 5

TH 90 SP2 - Load capacity F_x

Type	F_x [N]		
	Screw	Stat.	Dyn.
TH 90 SP2	12-05	9000	4300
	12-10	6600	3600

Tab. 7

TH 90 SP2 - Load capacity

Type	F_y [N]		F_z [N]		M_x [Nm]		M_y [Nm]		M_z [Nm]	
	Stat.	Dyn.	Stat.	Dyn.	Stat.	Dyn.	Stat.	Dyn.	Stat.	Dyn.
TH 90 SP2	6930	4616	6930	4616	188	126	26	17	26	17

See verification under static load and lifetime on page SL-2 and SL-3

Tab. 8

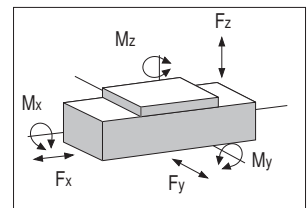

TH 90 SP4

TH 90 SP4 Dimensions (dual carriage)

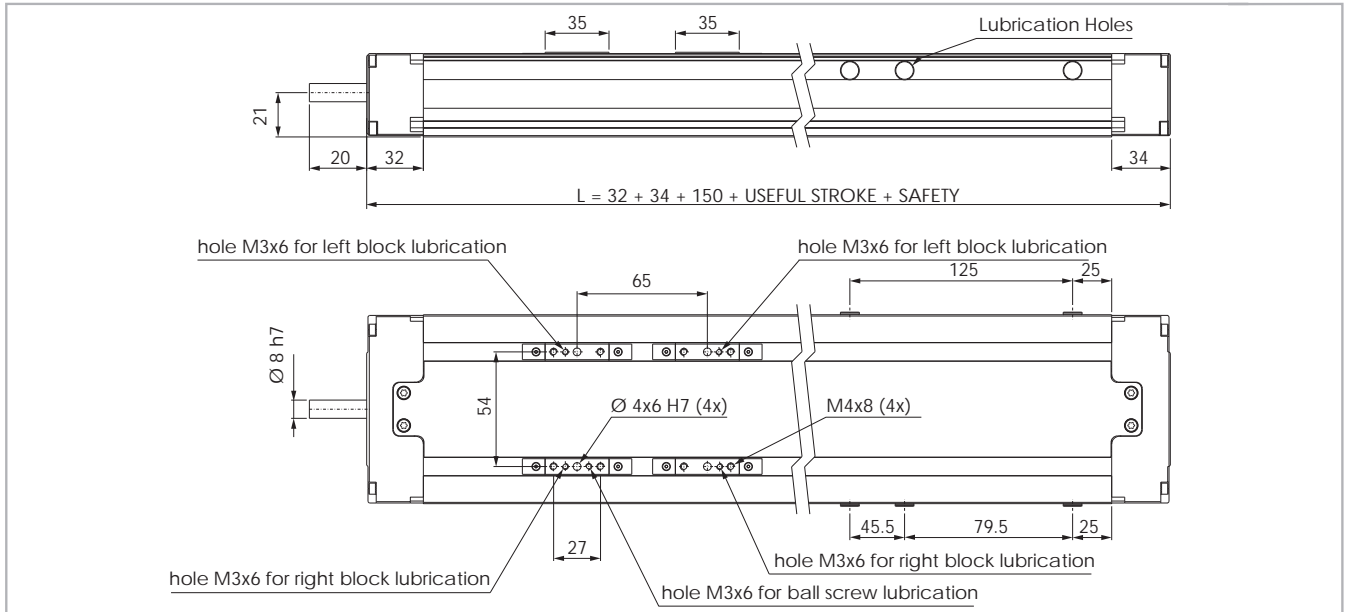

Fig. 3

Technical data

	Type
	TH 90 SP4
Max. useful stroke length [mm]	600
Max. speed [m/s]	See page PS-12
Carriage weight [kg]	0.90
Zero travel weight [kg]	2.04
Weight for 100 mm useful stroke [kg]	0.6

Tab. 9

Moments of inertia of the aluminum body

Type	I_x [10 ⁷ mm ⁴]	I_y [10 ⁷ mm ⁴]	I_p [10 ⁷ mm ⁴]
TH 90 SP4	0.0130	0.0968	0.1098

Tab. 11

Ball screw precision

Type	Max. positioning precision [mm/300mm]		Max. repeatability precision [mm]	
	ISO 5	ISO 7	ISO 5	ISO 7
TH 90 / 12-05	0.023	0.05	0.02	0.02
TH 90 / 12-10	0.023	0.05	0.02	0.02

Tab. 10

TH 90 SP4 - Load capacity F_x

Type	F_x [N]		
	Screw	Stat.	Dyn
TH 90 SP4	12-05	9000	4300
	12-10	6600	3600

Tab. 12

TH 90 SP4 - Load capacity

Type	F_y [N]		F_z [N]		M_x [Nm]		M_y [Nm]		M_z [Nm]	
	Stat.	Dyn	Stat.	Dyn	Stat.	Dyn	Stat.	Dyn	Stat.	Dyn
TH 90 SP4	13860	9232	13860	9232	377	251	450	300	450	300

See verification under static load and lifetime on page SL-2 and SL-3

Tab. 13

Note: for SP4 model the load capacities are valid only when the sliders are fixed together

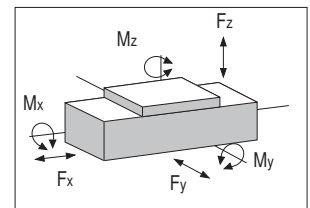

> TH 110 SP2

TH 110 SP2 Dimensions (single carriage)

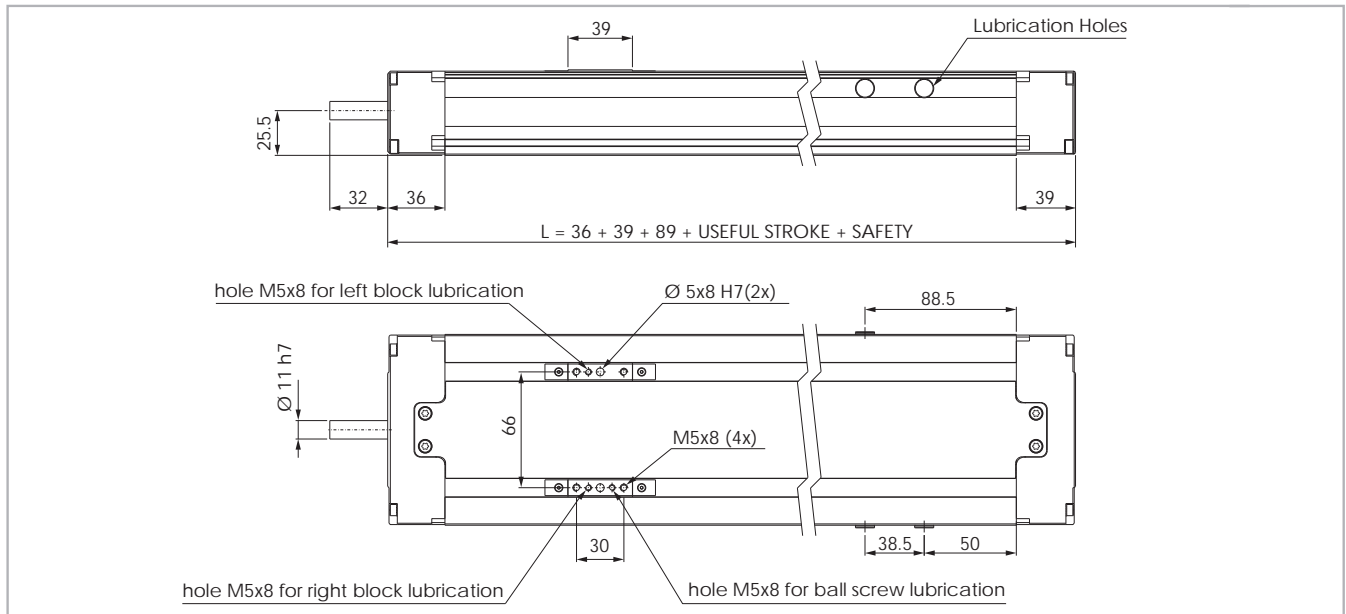

Fig. 4

Technical data

	Type
	TH 110 SP2
Max. useful stroke length [mm]	1411
Max. speed [m/s]	See page PS-12
Carriage weight [kg]	0.76
Zero travel weight [kg]	2.65
Weight for 100 mm useful stroke [kg]	0.83

Tab. 14

Moments of inertia of the aluminum body

Type	I_x [10 ⁷ mm ⁴]	I_y [10 ⁷ mm ⁴]	I_p [10 ⁷ mm ⁴]
TH 110 SP2	0.0287	0.2040	0.2327

Tab. 16

Ball screw precision

Type	Max. positioning precision [mm/300mm]		Max. repeatability precision [mm]	
	ISO 5	ISO 7	ISO 5	ISO 7
TH 110 / 16-05	0.023	0.05	0.005	0.045
TH 110 / 16-10	0.023	0.05	0.005	0.045
TH 110 / 16-16	0.023	0.05	0.005	0.045

Tab. 15

TH 110 SP2 - Load capacity F_x

Type	F_x [N]		
	Screw	Stat.	Dyn.
TH 110 SP2	16-05	17195	12640
	16-10	13420	9900
	16-16	13900	9900

Tab. 17

TH 110 SP2 - Load capacity

Type	F_y [N]		F_z [N]		M_x [Nm]		M_y [Nm]		M_z [Nm]	
	Stat.	Dyn.	Stat.	Dyn.	Stat.	Dyn.	Stat.	Dyn.	Stat.	Dyn.
TH 110 SP2	24200	14560	24200	14560	774	466	132	74	132	74

See verification under static load and lifetime on page SL-2 and SL-3

Tab. 18

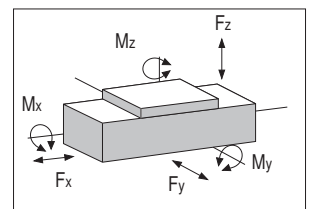

> TH 110 SP4

TH 110 SP4 Dimensions (Dual carriage)

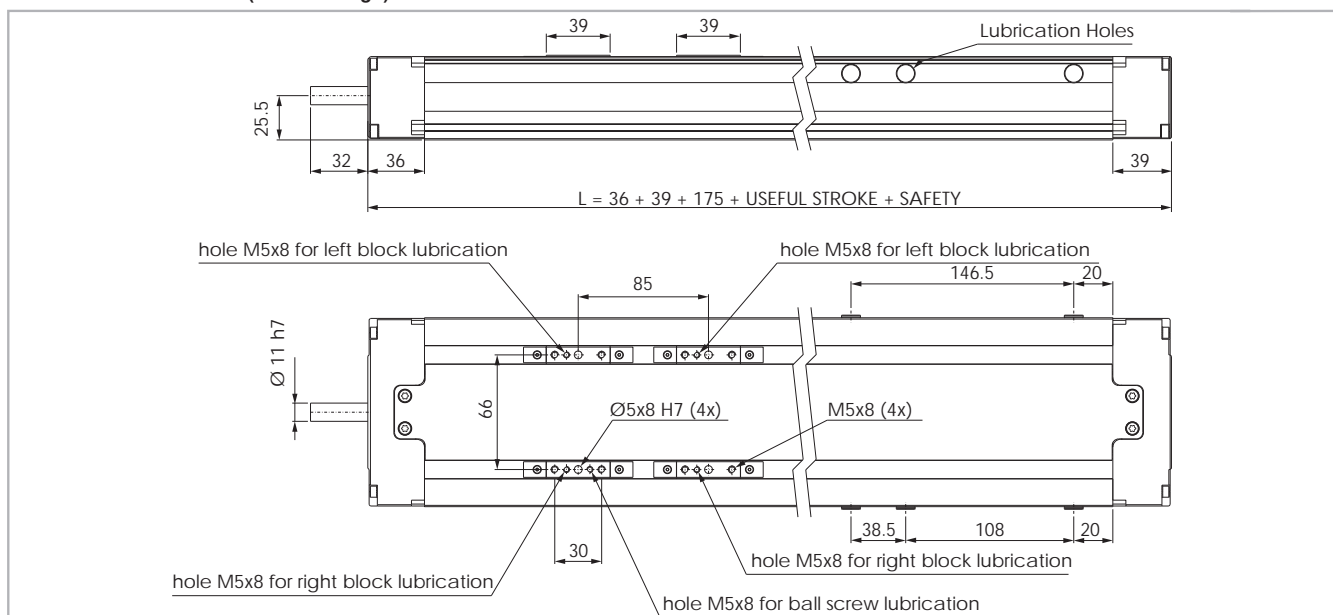

Fig. 5

Technical data

	Type
	TH 110 SP4
Max. useful stroke length [mm]	1325
Max. speed [m/s]	See page PS-12
Carriage weight [kg]	1.26
Zero travel weight [kg]	4.00
Weight for 100 mm useful stroke [kg]	0.83

Tab. 19

Moments of inertia of the aluminum body

Type	I_x [10 ⁷ mm ⁴]	I_y [10 ⁷ mm ⁴]	I_p [10 ⁷ mm ⁴]
TH 110 SP4	0.0287	0.2040	0.2327

Tab. 21

Ball screw precision

Type	Max. positioning precision [mm/300mm]		Max. repeatability precision [mm]	
	ISO 5	ISO 7	ISO 5	ISO 7
TH 110 / 16-05	0.023	0.05	0.005	0.045
TH 110 / 16-10	0.023	0.05	0.005	0.045
TH 110 / 16-16	0.023	0.05	0.005	0.045

Tab. 20

TH 110 SP4 - Load capacity F_x

Type	F_x [N]		
	Screw	Stat.	Dyn
TH 110 SP4	16-05	17195	12640
	16-10	13420	9900
	16-16	13900	9900

Tab. 22

TH 110 SP4 - Load capacity

Type	F_y [N]		F_z [N]		M_x [Nm]		M_y [Nm]		M_z [Nm]	
	Stat.	Dyn	Stat.	Dyn	Stat.	Dyn	Stat.	Dyn	Stat.	Dyn
TH 110 SP4	48400	29120	48400	29120	1549	932	1356	816	1356	816

See verification under static load and lifetime on page SL-2 and SL-3

Note: for SP4 model the load capacities are valid only when the sliders are fixed together

Tab. 23

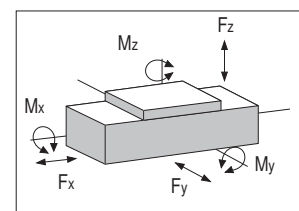

> TH 145 SP2

TH 145 SP2 Dimensions (single carriage)

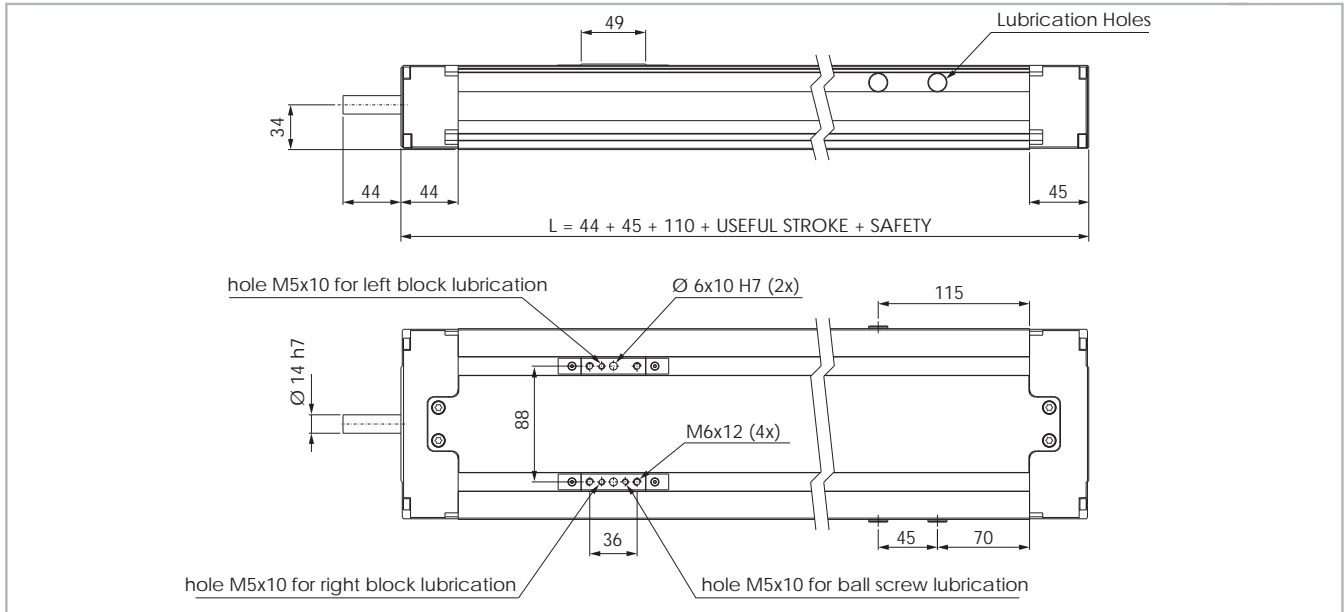

Fig. 6

Technical data

	Type
	TH 145 SP2
Max. useful stroke length [mm]	1690
Max. speed [m/s]	See page PS-12
Carriage weight [kg]	1.45
Zero travel weight [kg]	5.9
Weight for 100 mm useful stroke [kg]	1.6

Tab. 24

Moments of inertia of the aluminum body

Type	I_x [10 ⁷ mm ⁴]	I_y [10 ⁷ mm ⁴]	I_p [10 ⁷ mm ⁴]
TH 145 SP2	0.090	0.659	0.749

Tab. 26

Ball screw precision

Type	Max. positioning precision [mm/300mm]		Max. repeatability precision [mm]	
	ISO 5	ISO 7	ISO 5	ISO 7
TH 145 / 20-05	0.023	0.05	0.005	0.045
TH 145 / 20-20	0.023	0.05	0.005	0.045
TH 145 / 25-10	0.023	0.05	0.005	0.045

Tab. 25

TH 145 SP2 - Load capacity F_x

Type	F_x [N]		
	Screw	Stat.	Dyn.
TH 145 SP2	20-05	23545	14700
	20-20	19445	12250
	25-10	29573	16270

Tab. 27

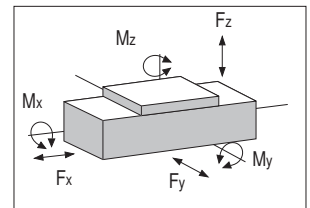

TH 145 SP2 - Load capacity

Type	F_y [N]		F_z [N]		M_x [Nm]		M_y [Nm]		M_z [Nm]	
	Stat.	Dyn.	Stat.	Dyn.	Stat.	Dyn.	Stat.	Dyn.	Stat.	Dyn.
TH 145 SP2	43400	34800	43400	34800	1888	1514	310	240	310	240

See verification under static load and lifetime on page SL-2 and SL-3

Tab. 28

TH 145 SP4

TH 145 SP4 Dimensions (dual carriage)

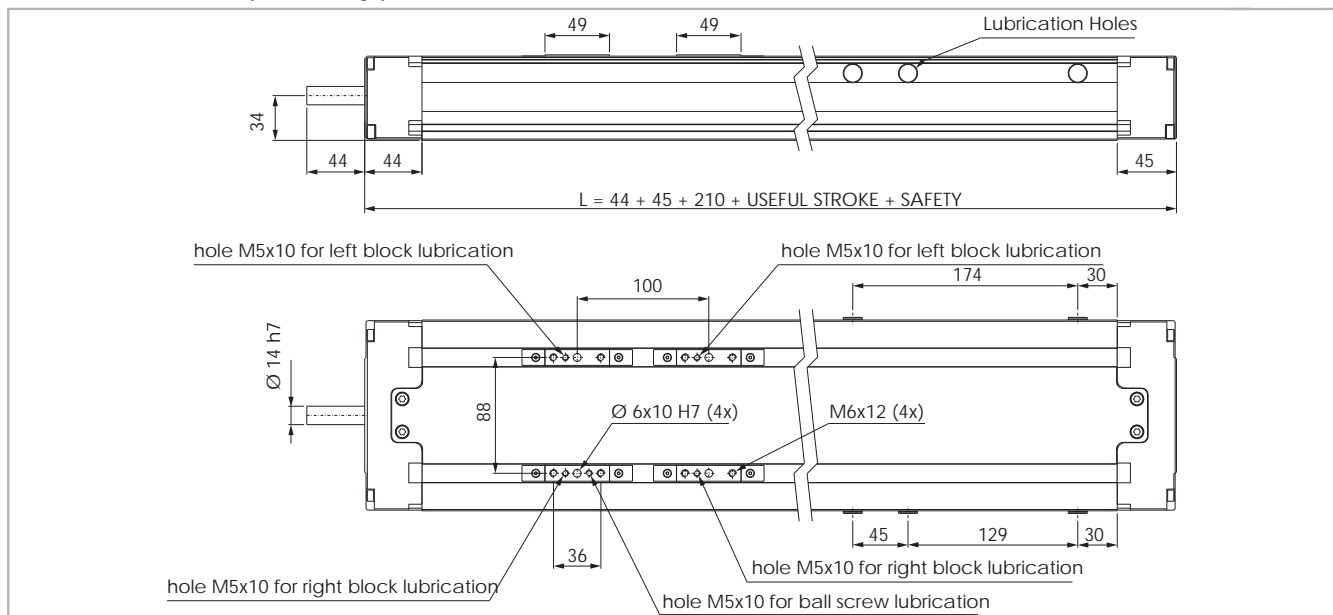

Fig. 7

Technical data

	Type
	TH 145 SP4
Max. useful stroke length [mm]	1590
Max. speed [m/s]	See page PS-12
Carriage weight [kg]	2.42
Zero travel weight [kg]	8.3
Weight for 100 mm useful stroke [kg]	1.6

Tab. 29

Moments of inertia of the aluminum body

Type	I_x [10^7 mm^4]	I_y [10^7 mm^4]	I_p [10^7 mm^4]
TH 145 SP4	0.090	0.659	0.749

Tab. 31

Ball screw precision

Type	Max. positioning precision [mm/300mm]		Max. repeatability precision [mm]	
	ISO 5	ISO 7	ISO 5	ISO 7
TH 145 / 20-05	0.023	0.05	0.005	0.045
TH 145 / 20-20	0.023	0.05	0.005	0.045
TH 145 / 25-10	0.023	0.05	0.005	0.045

Tab. 30

TH 145 SP4 - Load capacity F_x

Type	F_x [N]		
	Screw	Stat.	Dyn.
TH 145 SP4	20-05	23545	14700
	20-20	19445	12250
	25-10	29573	16270

Tab. 32

TH 145 SP4 - Load capacity

Type	F_y [N]		F_z [N]		M_x [Nm]		M_y [Nm]		M_z [Nm]	
	Stat.	Dyn.	Stat.	Dyn.	Stat.	Dyn.	Stat.	Dyn.	Stat.	Dyn.
TH 145 SP4	86800	69600	86800	69600	3776	3028	2855	2290	2855	2290

See verification under static load and lifetime on page SL-2 and SL-3

Tab. 33

Note: for SP4 model the load capacities are valid only when the sliders are fixed together

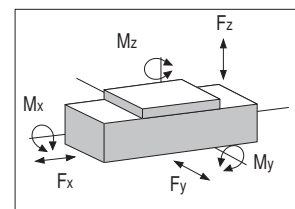

> Motor connections

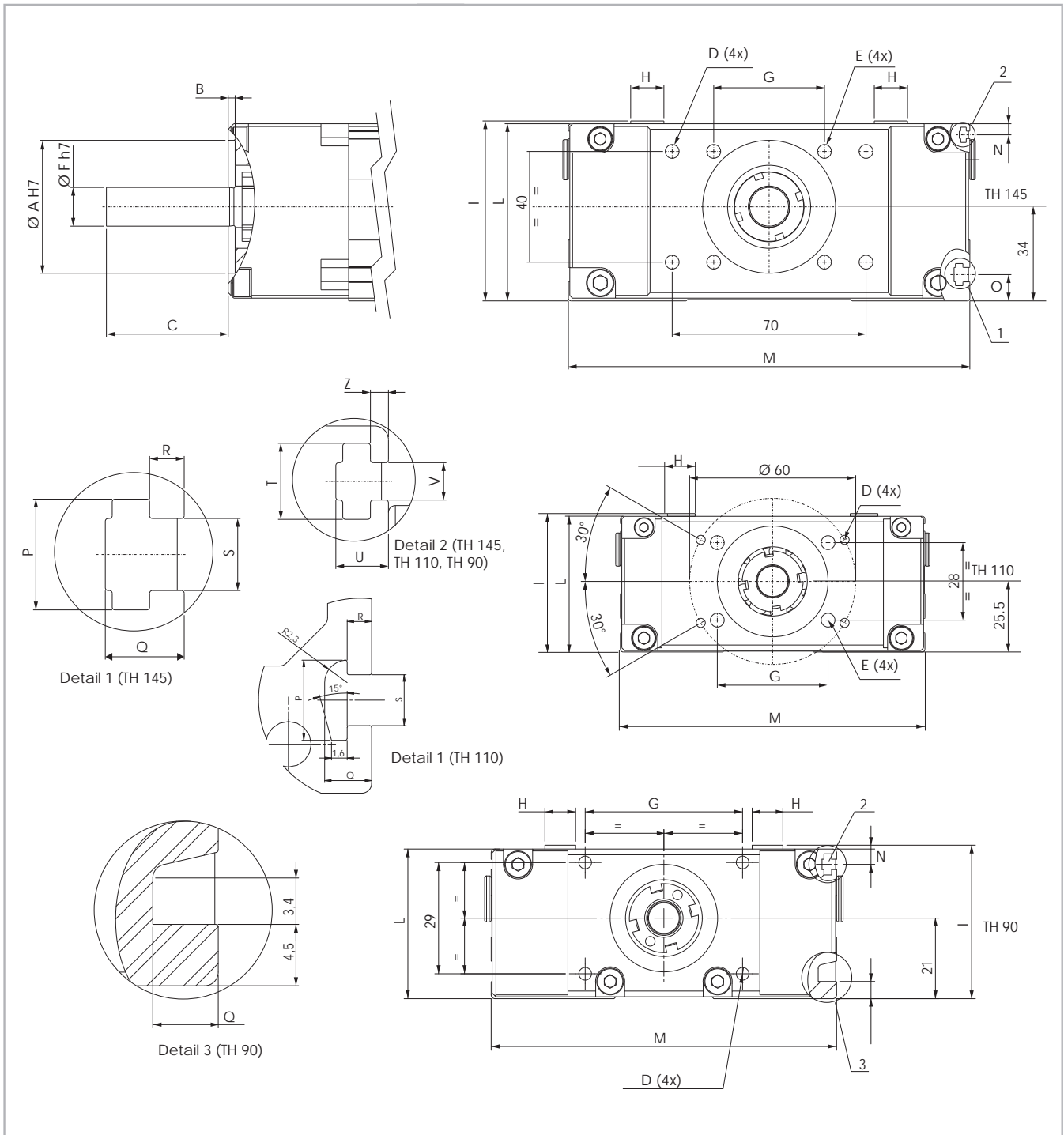

Fig. 8

Units [mm]

Type	A	B	C	D	E	F	G	H	I	L	M	N	O	P	Q	R	S	T	U	V	Z
TH 90	28	2.5	20	M4x8	-	8	41	8	40	39	90	4	4.5	-	4.8	-	-	5.5	3.8	2.7	1.3
TH 110	40	2.5	32	M4x8	M6x10	11	40	10	50	49	110	4	9.5	8	4.8	2.5	5.2	5.5	3.8	2.7	1.3
TH 145	48	2.5	44	M6x10	M6x12	14	40	12	65	64	145	4	9.5	8	5.7	2.5	5.2	5.5	3.8	2.7	1.3

Tab. 34

> Lubrication

SP linear units with ball bearing guides

SP Linear units are equipped with self lubricating linear ball guides. The ball bearing carriages of the SP versions are also fitted with a retention cage that eliminates "steel-steel" contact between adjacent revolving parts and prevents misalignment of these in the circuits.

Special lubrication reservoirs are mounted on the front plates of the linear blocks which continuously provide the necessary amount of grease to the

ball raceways under load. These lubrication reservoirs also considerably reduce the frequency of lubrication of the module. This system guarantees a long interval between maintenances: SP version: every 5000 km or 1 year of use, based on the value reached first. If a longer service life is required or in case of high dynamic or high loaded applications please contact our offices for further verification.

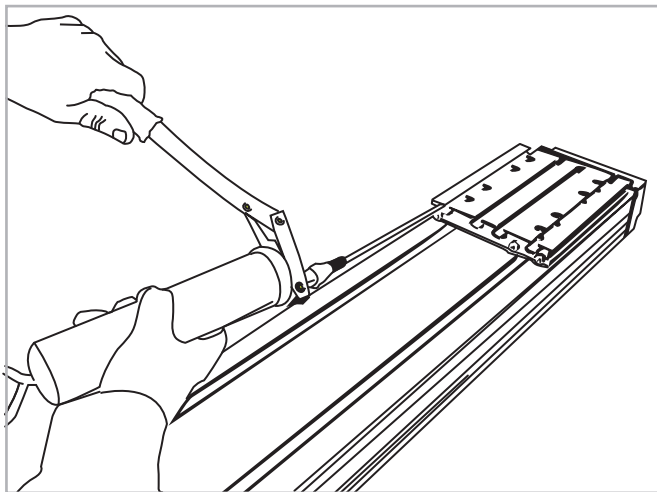

Fig. 9

Ball screws

The ball screw nuts for the Rollon TH series linear slides should be re-lubricated every 50 million revolutions. Use the following conversion table to determine the re-lubrication interval in linear distance traveled (km) as shown.

Type	Quantity [g] for grease nipple
12-05	0.3
12-10	0.3
16-05	0.6
16-10	0.8
16-16	1.0
20-05	0.9
20-20	1.7
25-10	1.7

Tab. 35

Comparison table for no. of revolutions/linear distance	
Turns	50 · 10 ⁶
Lead 5	250 km
Lead 10	500 km
Lead 16	800 km
Lead 20	1000 km

Tab. 36

Amount of lubricant needed to lubricate carriages:

Type	Quantity [g]
TH 90	1
TH 110	0.8
TH 145	1.4

Tab. 37

- Insert grease gun into the specific grease nipples.
- Type of lubricant: Lithium soap grease of class NLGI 2.
- For specially stressed applications or difficult environmental conditions, lubrication should be carried out more frequently. Apply to Rollon for further advice.

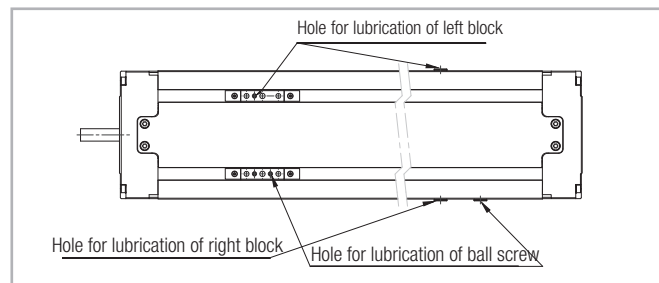
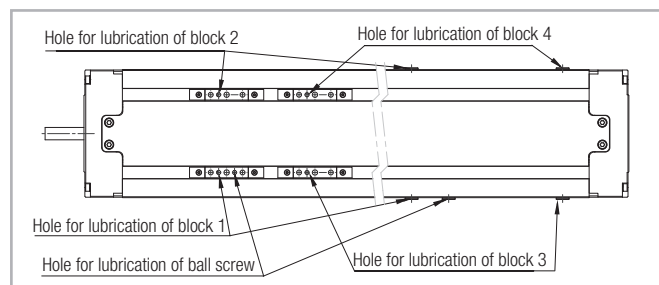

Fig. 10



Please refer to page PS-5 for the position of the holes for lubrication for TH 90 SP 4. Fig. 11

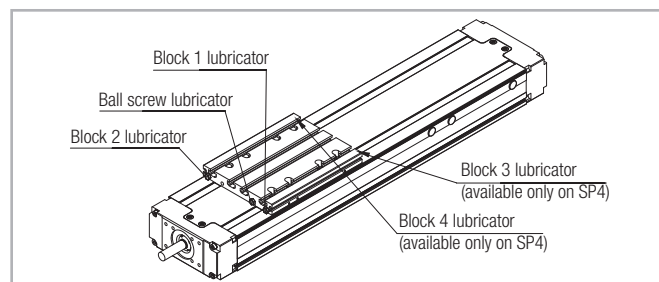

Fig. 12

> Critical speed

The maximum linear speed of Rollon TH -series linear units depends on the critical speed of the screw (based on its diameter and length) and on the max. permissible speed of the ball screw nut used. The limit speed for Rollon TH series units can be calculated using the following formula:

$$V_{\max} = \frac{f}{\ell_n^2} \text{ [m/s]}$$

Tab. 38

> Calculation factors

Screw diameter and lead	Calculation factor (f)	Critical length of the screw (ℓ_n) [mm]
12-05	$0.629 \cdot 10^5$	$\ell_n = LT - \left(\frac{LT - Cu}{2} \right)$ LT = Total length Cu = Useful stroke
12-10	$1.258 \cdot 10^5$	
16-05	$1.487 \cdot 10^5$	
16-10	$3.160 \cdot 10^5$	
16-16	$5.230 \cdot 10^5$	
20-05	$2.155 \cdot 10^5$	
20-20	$8.608 \cdot 10^5$	
25-10	$5.352 \cdot 10^5$	

Tab. 39

The maximum linear speed, which depends on the ball screw nut, is indicated directly in the table below.

Screw diameter and lead	Max. linear speed of the ball screw nut [m/s]	
	ISO 7	ISO 5
12-05	0.56	0.69
12-10	1.11	1.39
16-05	0.42	0.52
16-10	0.83	1.04
16-16	1.33	1.67
20-05	0.33	0.42
20-20	1.33	1.67
25-10	0.53	0.67

Tab. 40

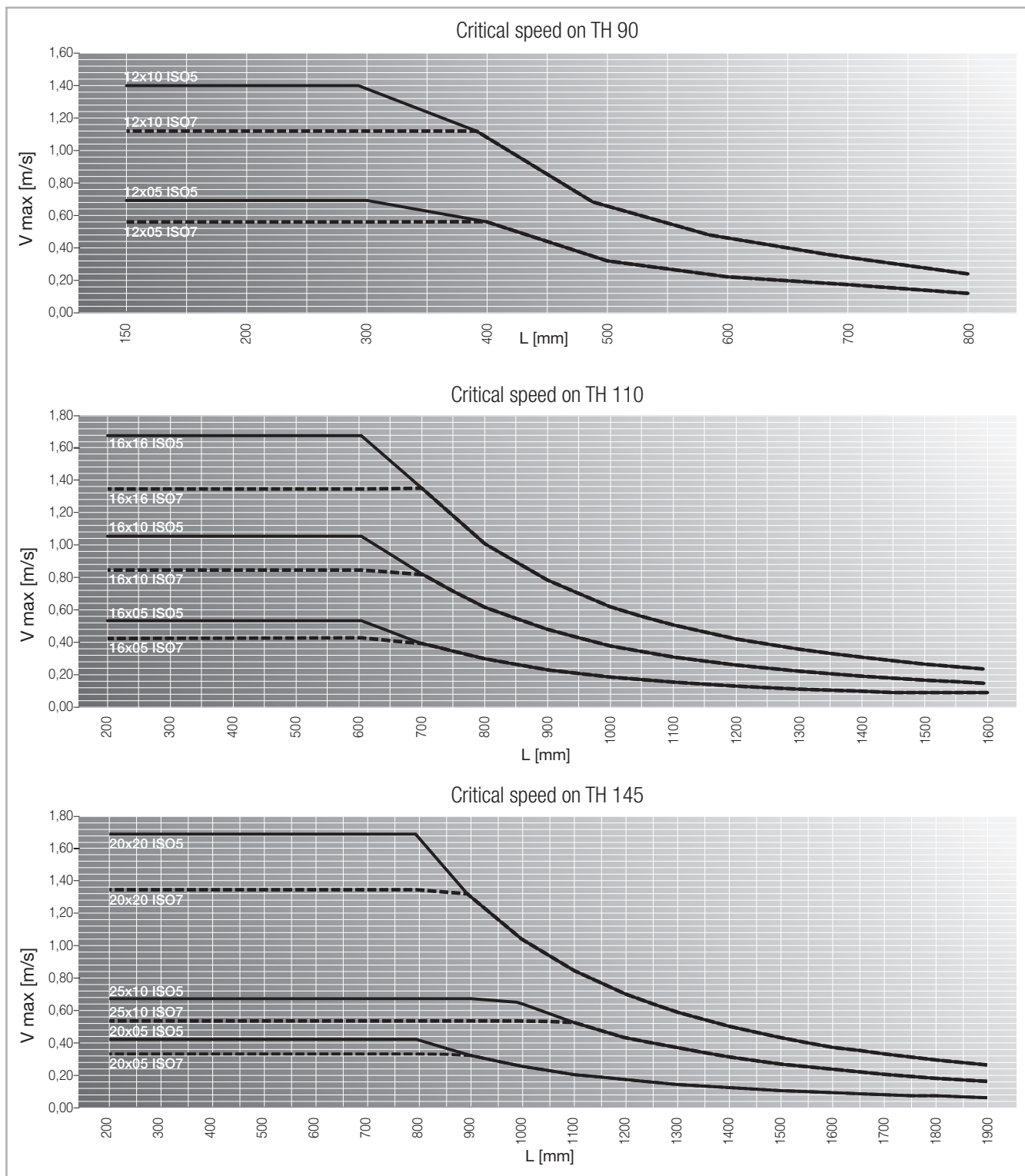

Fig. 13

> Accessories

Fixing by brackets

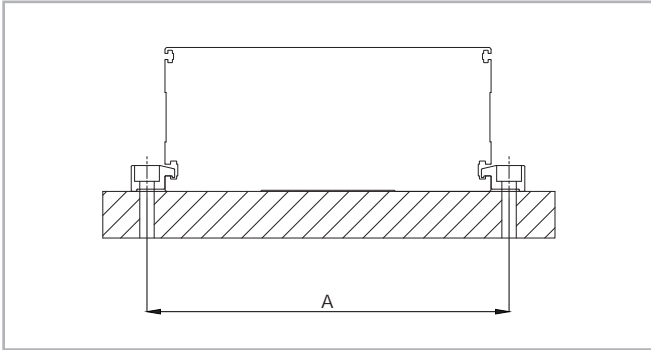

Fig. 14

Units (mm)

Type	A Unit mm
TH 90	102
TH 110	126
TH 145	161

Tab. 41

Fixing brackets

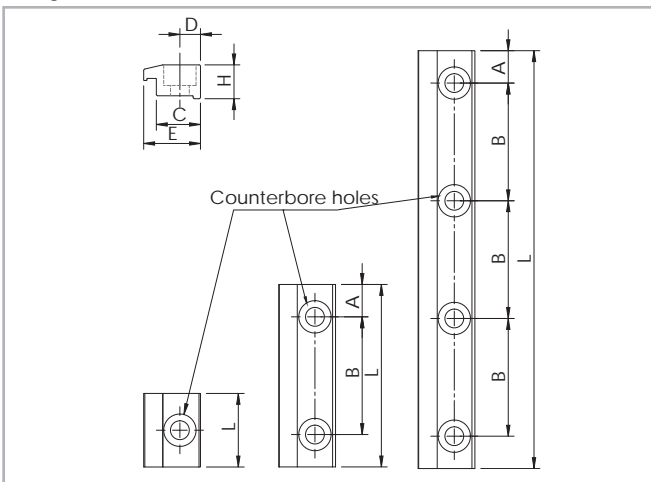

Fig. 15

Dimensions (mm)

Type	N° holes	Counterbore for screw	A	B	C	D	E	H	L	Code Rollon
TH 90	2	M4	11	40	10.5	4.5	14.5	9.1	62	1003385
	4	M4	8.5	30	10.5	4.5	14.5	9.1	107	1003509
	4	M4	8.5	20	10.5	4.5	14.5	9.1	77	1003510
	1	M4	-	-	10.5	4.5	14.5	9.1	25	1003612
TH 110 TH 145	4	M5	8.5	30	15	7	19.3	11.5	107	1002805
	4	M6	11	40	15	7	19.3	11.5	142	1002864
	1	M6	-	-	15	7	19	11.5	25	1002970
	2	M6	11	40	15	7	19	11.5	62	1002971
	4	M5	20	20	15	7	19	11.5	100	1003311

Tab. 42

T nuts

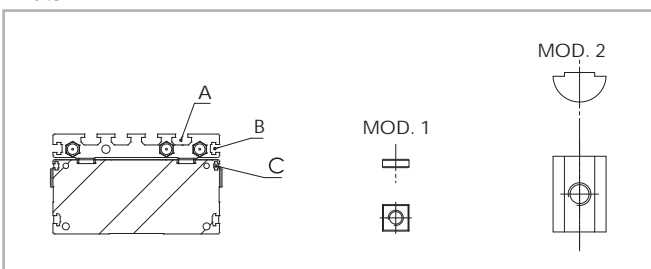

Fig. 16

Units (mm)

Type	A	B	C
TH 90	Mod. 2 M5	-	Mod. 1 M2.5
TH 110	Mod. 2 M5	Mod. 1 M4	Mod. 1 M2.5
TH 145	Mod. 2 M6	Mod. 1 M4	Mod. 1 M2.5
Code	6000436 (M5)/6000437 (M6)	963.0407.81	6001361

Tab. 43

Proximity

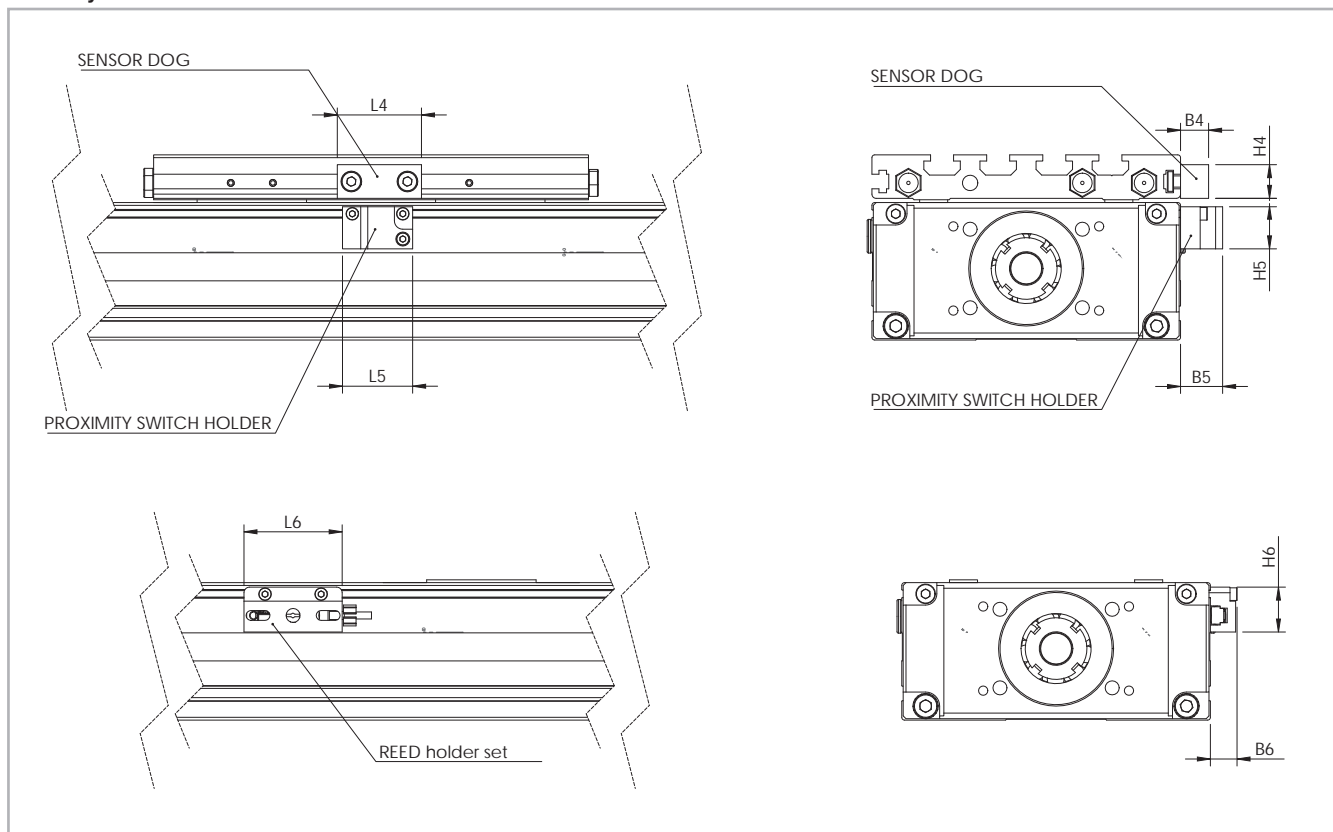

Fig. 17

Units (mm)

	B4	B5	B6	L4	L5	L6	H4	H5	H6	Sensor	Proximity holder set	Sensor dog	REED holder set
TH 90	10	15	9.5	12	25	35	6	15	16	Ø 8	G001193	G001203	G001204
TH 110	10	15	9.5	30	25	35	12	15	16	Ø 8	G001193	G001198	G001204
TH 145	10	15	9.5	30	25	35	12	15	16	Ø 8	G001193	G001198	G001204

Tab. 44

External carriage

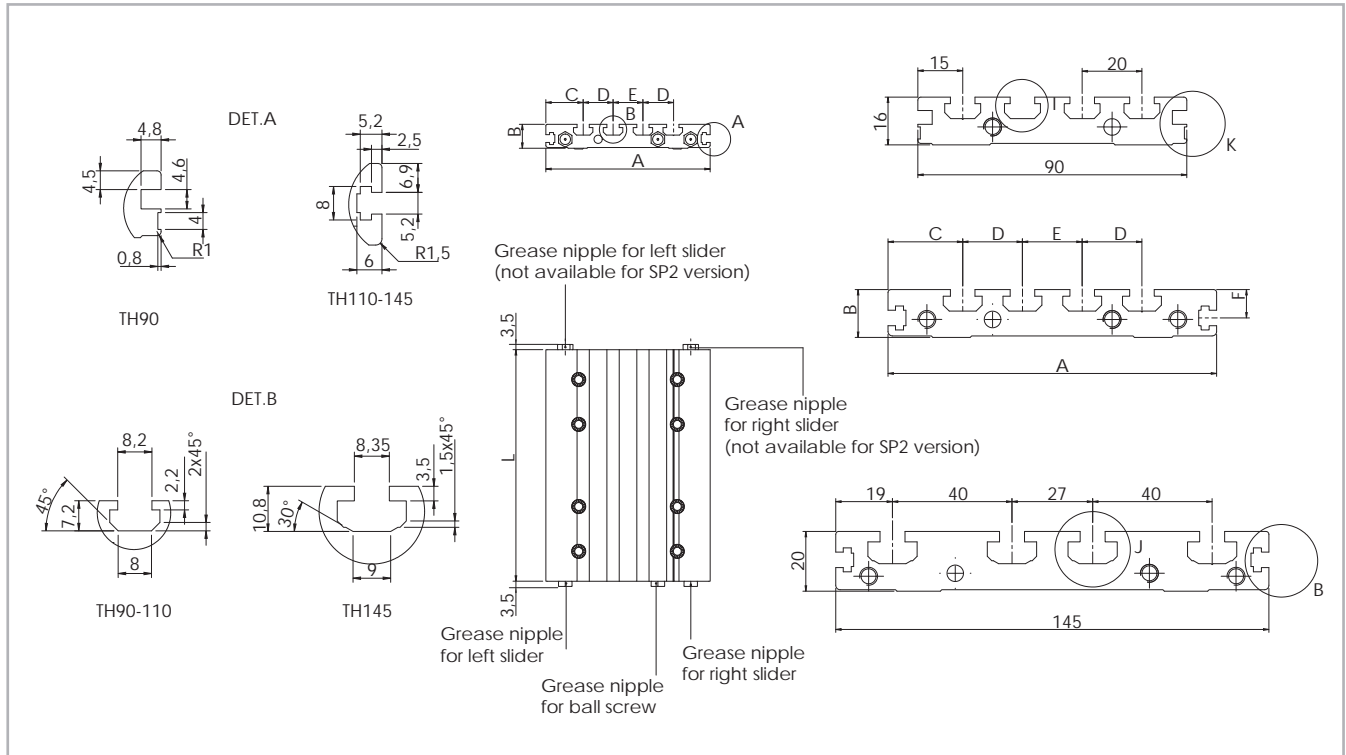

Fig. 18

External carriage for SP2	Type	A	B	C	D	E	F	L	Code
	TH 90	90	16	15	20	20	6.8	60	G001195
	TH 110	110	16	25	20	20	9.5	60	G001059
	TH 145	145	20	19	40	27	9.5	80	G001062

Tab. 45

External carriage for SP4	Type	A	B	C	D	E	F	L	Code
	TH 90	90	16	15	20	20	6.8	125	G001194
	TH 110	110	16	25	20	20	9.5	155	G001060
	TH 145	145	20	19	40	27	9.5	190	G001061

Tab. 46

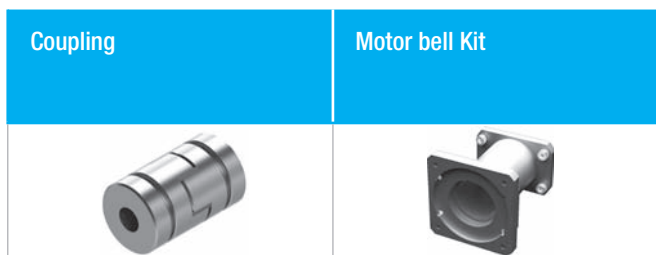

see pg. PS-18

Tab. 47

Assembly kits

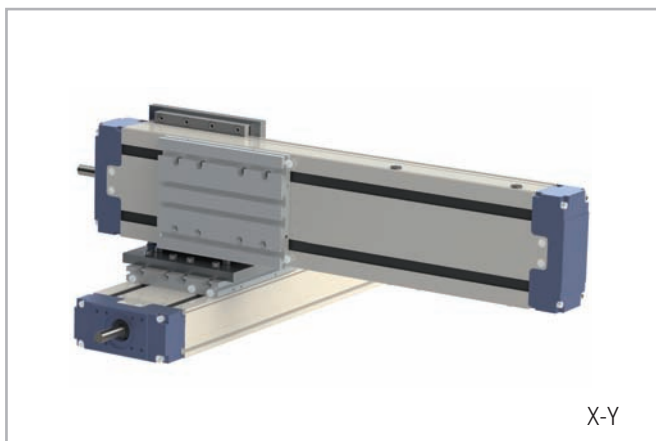

X-Y

Fig. 19

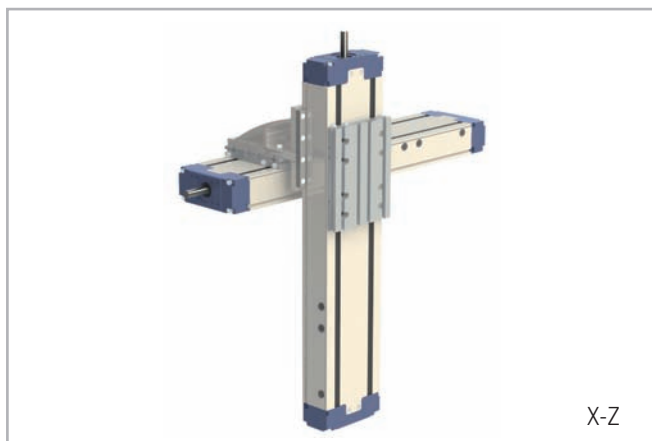

X-Z

Fig. 20

For the direct assembly of TH linear units on multiple axis system Rollon offers dedicated assembly kits. The table below shows the allowed combinations as well as the assembly kit codes.

Kit	Code
 TH 90 - TH 90 XY	G001199
 TH 90 - TH 110 XZ	G001205
 TH 110 - TH 110 XY	G001080
 TH 110 - TH 110 XZ	G001083
 TH 110 - TH 145 XY	G001079
 TH 110 - TH 145 XZ	G001084
 TH 145 - TH 145 XY	G001081
 TH 145 - TH 145 XZ	G001085

Tab. 48

Wrap around kit

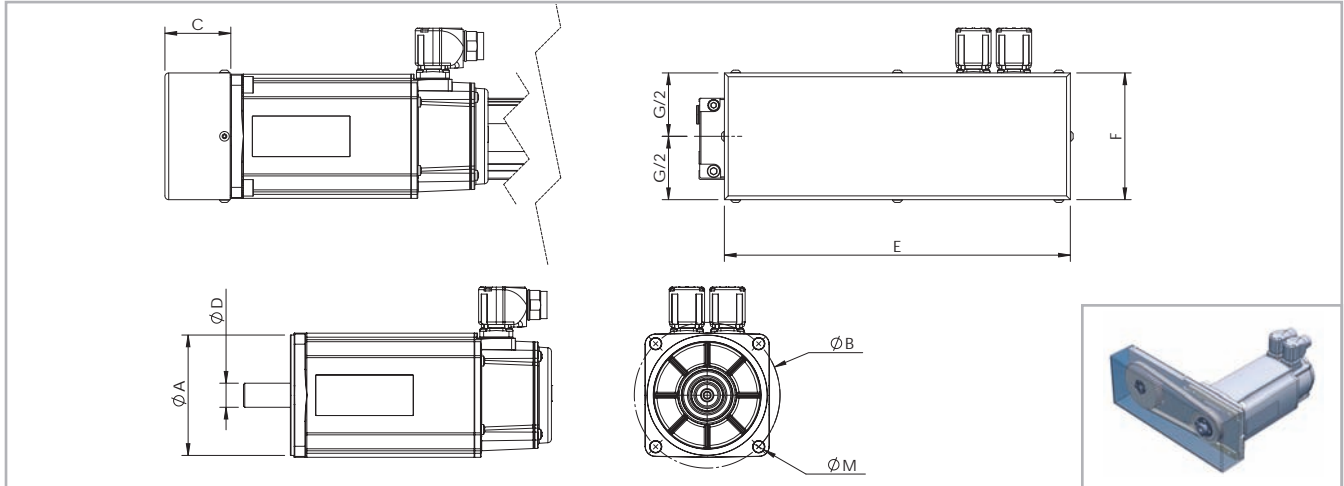

Fig. 21

Unit	Ratio	A	B	C	D	E	F	M	Code
TH 110	1 : 1	∅ 40	∅ 63	40.5	∅ 9	233	88	M4	G001011
TH 110	1 : 1	∅ 50	∅ 70	40.5	∅ 14	233	88	M4	G001055
TH 110	1 : 1	∅ 60	∅ 75	40.5	∅ 14	233	88	M6	G001013
TH 145	1 : 1	∅ 80	∅ 100	52	∅ 14	273	100	M6	G000984
TH 145	1 : 1	∅ 95	∅ 115	52	∅ 19	273	100	M8	G000988

For further information please contact Rollon Technical Dept.

Tab. 49

Mounting of the motor

Rollon TH Series linear units can be supplied with different types of motor mounts, adapter flanges, and with torsionally stiff couplings for screw and motor connections that enable fast, hassle-free assembly of the motors.

The types of bells available for the related units are shown in the table

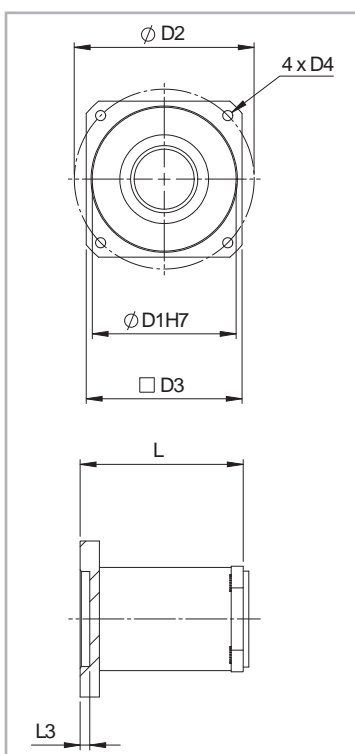

Fig. 22

Unit	D1	D2	D3	D4	L	L3	Code
TH90	∅ 40	∅ 63	56	M5	50	3	G001192
TH110	∅ 60	∅ 75	65	M6	68	4	G001051
TH110	∅ 73,1	∅ 98,4	86	M5	76.7	2	G001074
TH110	∅ 60	∅ 75	65	M5	68	4	G001119
TH110	∅ 50	∅ 70	65	∅ 5.4	75	11	G001200
TH145	∅ 50	∅ 70	80x60	M4	92	21	G000979
TH145	∅ 70	∅ 85	80x85	M6	92	4	G001066
TH145	∅ 70	∅ 90	80x85	M5	92	5	G001067
TH145	∅ 80	∅ 100	90	M6	92	4	G001068
TH145	∅ 50	∅ 65	80x85	M5	92	21	G001069
TH145	∅ 60	∅ 75	80x85	M6	92	4	G001070
TH145	∅ 50	∅ 70	80x85	M5	92	21	G001071
TH145	∅ 73	∅ 98,4	85	M5	92	4	G001072
TH145	∅ 55	68X40	85x60	∅6,4	82	11	G001073

Tab. 50

Ordering key



> Identification code for the TH linear units

H	09	1205	5P	0800	1A	
	09=90	12-05	5P=ISO 5		1A=SP2 set for motor bell kit	
	11=110	12-10	7N=ISO 7		2A=SP4 set for motor bell kit	
	14=145	16-05			3A=SP2 set for wrap around kit	
		16-10			4A=SP4 set for wrap around kit	
		16-16				
		20-05				
		20-20				
		25-10				
						Head configuration code
						L=total length of th unit
						Type see from pg. PS-4 to pg. PS-9, tab. 5, 10, 15, 20, 25, 30
						B/S diameter and lead see pg. PS-12
						Size see from pg. PS-4 to pg. PS-9
						Linear unit serie TH see pg. PS-2

In order to create identification codes for Actuator Line, you can visit: <http://configureactuator.rollon.com>

TT series

**> TT series description**

Fig. 23

TT

The TT is a linear actuator series mainly used for high accuracy positioning within a 10 μm range and precision repeatability within 5 μm . Manufactured using a very rigid extruded anodized aluminum base structure, this actuator series is designed for high loads and precise movements that are typically required in machine tools and other exacting machine design applications.

All mounting surfaces and reference datums have been produced to significantly reduce the deviations of pitch, yaw and roll along the entire stroke. The heavy duty carriage is driven by a C5 or C7 preloaded ball screw drive and the payload is supported by a system of four runner blocks mounted on two parallel linear guides. High speeds can be accomplished by specifying available super lead ball screw drivers.

The TT series contains all the necessary features and hardware to make multi-axis configurations and assembly easy. All TT units are 100% inspected and supplied with certificates of accuracy.

> The components

Aluminum base unit and carriage

The base and carriages of the Rollon TT series linear units were designed and manufactured in co-operation with industry experts to obtain the high-level of accuracy and maximize mechanical properties. Anodized aluminum alloy 6060 was used with dimensional tolerances complying with UNI 3879 standards. To guarantee highly precise movement, the bodies are precision machined on all outer surfaces and in the areas where the mechanical components are fitted, such as ball bearing guides and ball screw supports.

Linear motion system

Precision ball bearing guides with ground rails and preloaded blocks are used on Rollon TT series linear units. Use of this technology makes it possible to obtain the following features:

- High accuracy running parallelism
- High positioning accuracy
- High level of rigidity
- Reduced wear
- Low resistance to movement

Drive system

Rollon TT-series linear units use precision ball screws with either preloaded or non-preloaded ball screw nuts. The standard precision class of the ball screws used is ISO 5, however ISO 7 precision class is also available upon request. The ballscrew on the TH unit is available in different diameters and leads (see specifications tables). Use of this type of technology makes it possible to obtain the following features:

- High speed (for long pitch screws)
- High load capacity and accurate thrust forces
- Superior mechanical performance
- Reduced wear
- Low resistance to movement

Protection

Rollon TT-series linear units are equipped with bellows in order to protect the mechanical and electrical components inside the linear unit against contaminants. In addition to the bellows system, the ball bearing guides and ball screws have their own protection including scrapers and lip seals to remove contaminants from the raceways of the ball bearings.

General data about aluminum used: AL 6060

Chemical composition [%]

Al	Mg	Si	Fe	Mn	Zn	Cu	Impurities
Remainder	0.35-0.60	0.30-0.60	0.30	0.10	0.10	0.10	0.05-0.15

Tab. 51

Physical characteristics

Density	Coeff. of elasticity	Coeff. of thermal expansion (20°-100°C)	Thermal conductivity (20°C)	Specific heat (0°-100°C)	Resistivity	Melting point
$\frac{\text{kg}}{\text{dm}^3}$	$\frac{\text{kN}}{\text{mm}^2}$	$\frac{10^{-6}}{\text{K}}$	$\frac{\text{W}}{\text{m} \cdot \text{K}}$	$\frac{\text{J}}{\text{kg} \cdot \text{K}}$	$\Omega \cdot \text{m} \cdot 10^{-9}$	°C
2.7	69	23	200	880-900	33	600-655

Tab. 52

Mechanical characteristics

Rm	Rp (02)	A	HB
$\frac{\text{N}}{\text{mm}^2}$	$\frac{\text{N}}{\text{mm}^2}$	%	—
205	165	10	60-80

Tab. 53

> TT 100

TT 100 Dimensions

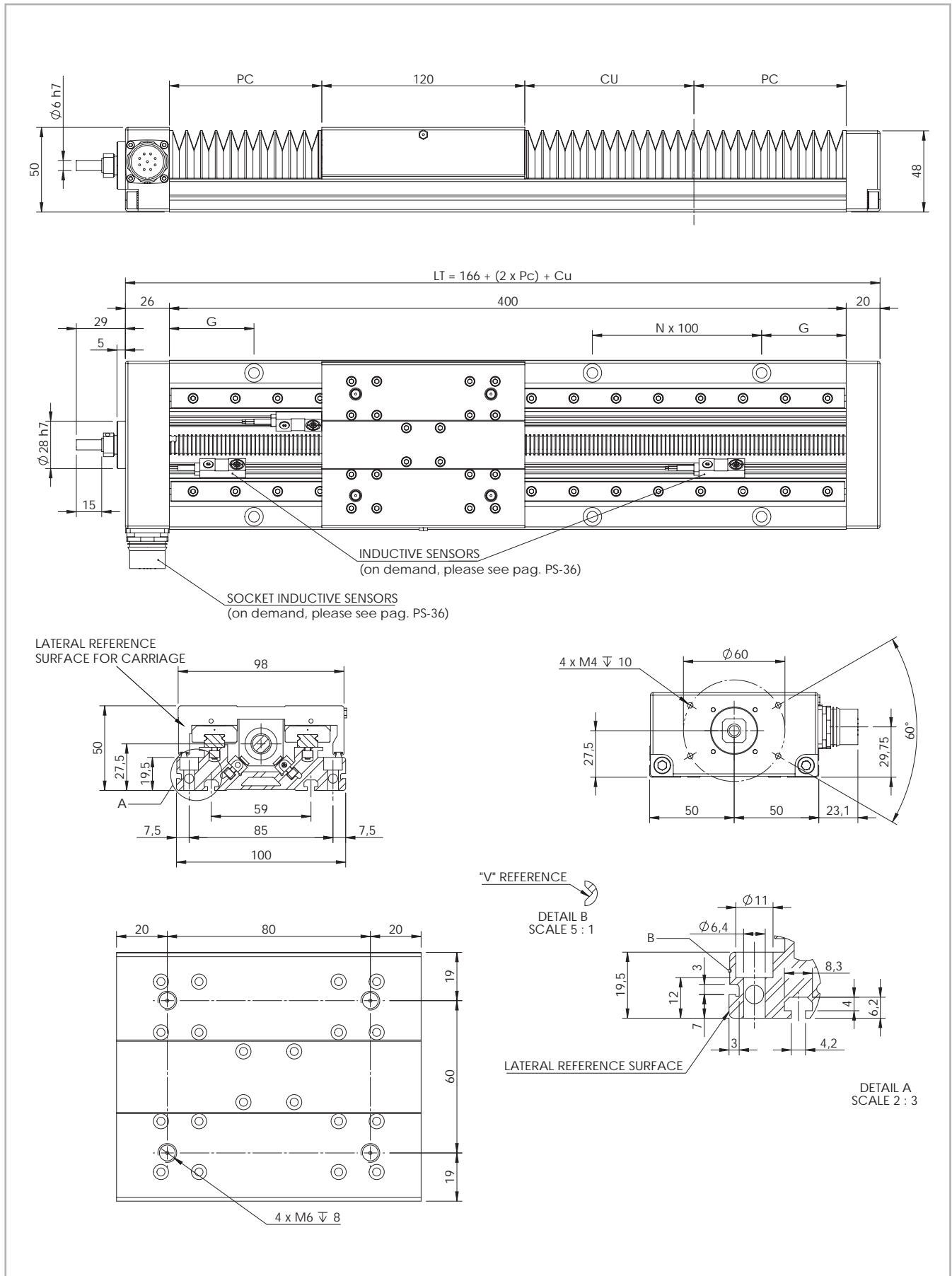

Fig. 24

Technical data

Useful stroke CU [mm]	Total length LT [mm]	G Dimension [mm]	Weight [Kg]
46	246	50	2.5
114	346	50	3
182	446	50	4
252	546	50	5
320	646	50	6
390	746	50	7
458	846	50	7
526	946	50	8
596	1046	50	9
664	1146	50	10
734	1246	50	11
802	1346	50	11
940	1546	50	13

Note: for the ballscrew 12/10 the max. useful stroke is 664 mm.

Tab. 54

Technical data

	Type
	TT 100
Max. speed [m/s]	See page PS-33
Carriage weight [kg]	0.93

Tab. 56

Moments of inertia of the aluminum body

Type	I_x [10 ⁷ mm ⁴]	I_y [10 ⁷ mm ⁴]	I_p [10 ⁷ mm ⁴]
TT 100	0.006	0.144	0.150

Tab. 57

Ball screw precision

Type	Max. positioning precision [mm/300mm]		Max. repeatability precision [mm]	
	ISO 5	ISO 7	ISO 5	ISO 7
TT 100 / 12-05	0.023	0.05	-	0.010
TT 100 / 12-10	0.023	0.05	-	0.010

Tab. 55

TT 100 - Load capacity F_x

Type	F_x [N]		
	Screw	Stat.	Dyn.
TT 100	12-05	12000	6600

Tab. 58

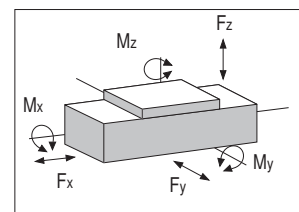

TT 100 - Load capacity

Type	F_y [N]		F_z [N]		M_x [Nm]		M_y [Nm]		M_z [Nm]	
	Stat.	Dyn.	Stat.	Dyn.	Stat.	Dyn.	Stat.	Dyn.	Stat.	Dyn.
TT 100	14000	8985	14000	8985	385	247	490	314	490	314

See verification under static load and lifetime on page SL-2 and SL-3

Tab. 59

> TT 155

TT 155 Dimensions

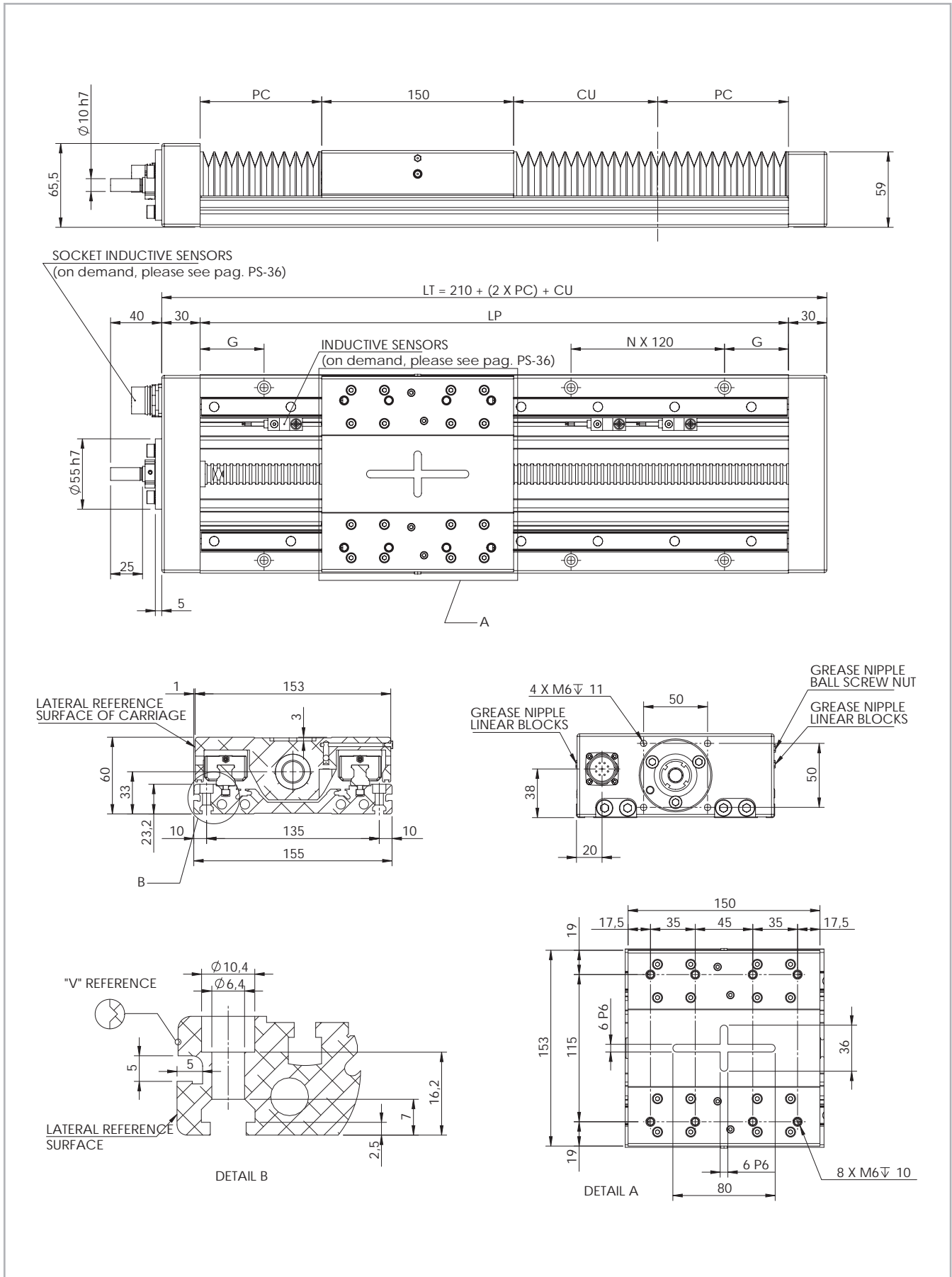

Fig. 25

Technical data

Useful stroke CU [mm]	Total length LT [mm]	G Dimension [mm]	Weight [Kg]
92	340	20	7.5
140	400	50	8.5
188	460	20	9
236	520	50	10
282	580	20	11
330	640	50	12
378	700	20	13
424	760	50	13
520	880	50	15
614	1000	50	17
710	1120	50	18
806	1240	50	20
900	1360	50	21
994	1480	50	23
1090	1600	50	25
1184	1720	50	26
1280	1840	50	28
1376	1960	50	30
1470	2080	50	31

Note: for the ballscrew Ø16 the max. useful stroke is 994 mm.

Tab. 60

Technical data

	Type
	TT 155
Max. speed [m/s]	See page PS-33
Carriage weight [kg]	2.93

Tab. 62

Moments of inertia of the aluminum body

Type	I_x [10 ⁷ mm ⁴]	I_y [10 ⁷ mm ⁴]	I_p [10 ⁷ mm ⁴]
TT 155	0.009	0.531	0.54

Tab. 63

Ball screw precision

Type	Max. positioning precision [mm/300mm]		Max. repeatability precision [mm]	
	ISO 5	ISO 7	ISO 5	ISO 7
TT 155 / 16-05	0.023	0.05	0.005	0.045
TT 155 / 16-10	0.023	0.05	0.005	0.045
TT 155 / 20-05	0.023	0.05	0.005	0.045
TT 155 / 20-20	0.023	0.05	0.005	0.045

Tab. 61

TT 155 - Load capacity F_x

Type	F_x [N]		
	Screw	Stat.	Dyn.
TT 155	16-05	16100	12300
	16-10	12300	9600
	20-05	21500	14300
	20-20	18800	13300

Tab. 64

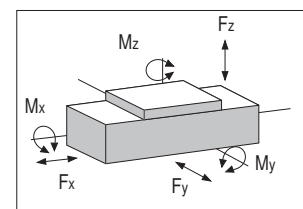

TT 155 - Load capacity

Type	F_y [N]		F_z [N]		M_x [Nm]		M_y [Nm]		M_z [Nm]	
	Stat.	Dyn.	Stat.	Dyn.	Stat.	Dyn.	Stat.	Dyn.	Stat.	Dyn.
TT 155	48400	29120	48400	29120	2541	1529	1533	922	1533	922

See verification under static load and lifetime on page SL-2 and SL-3

Tab. 65

> TT 225

TT 225 Dimensions

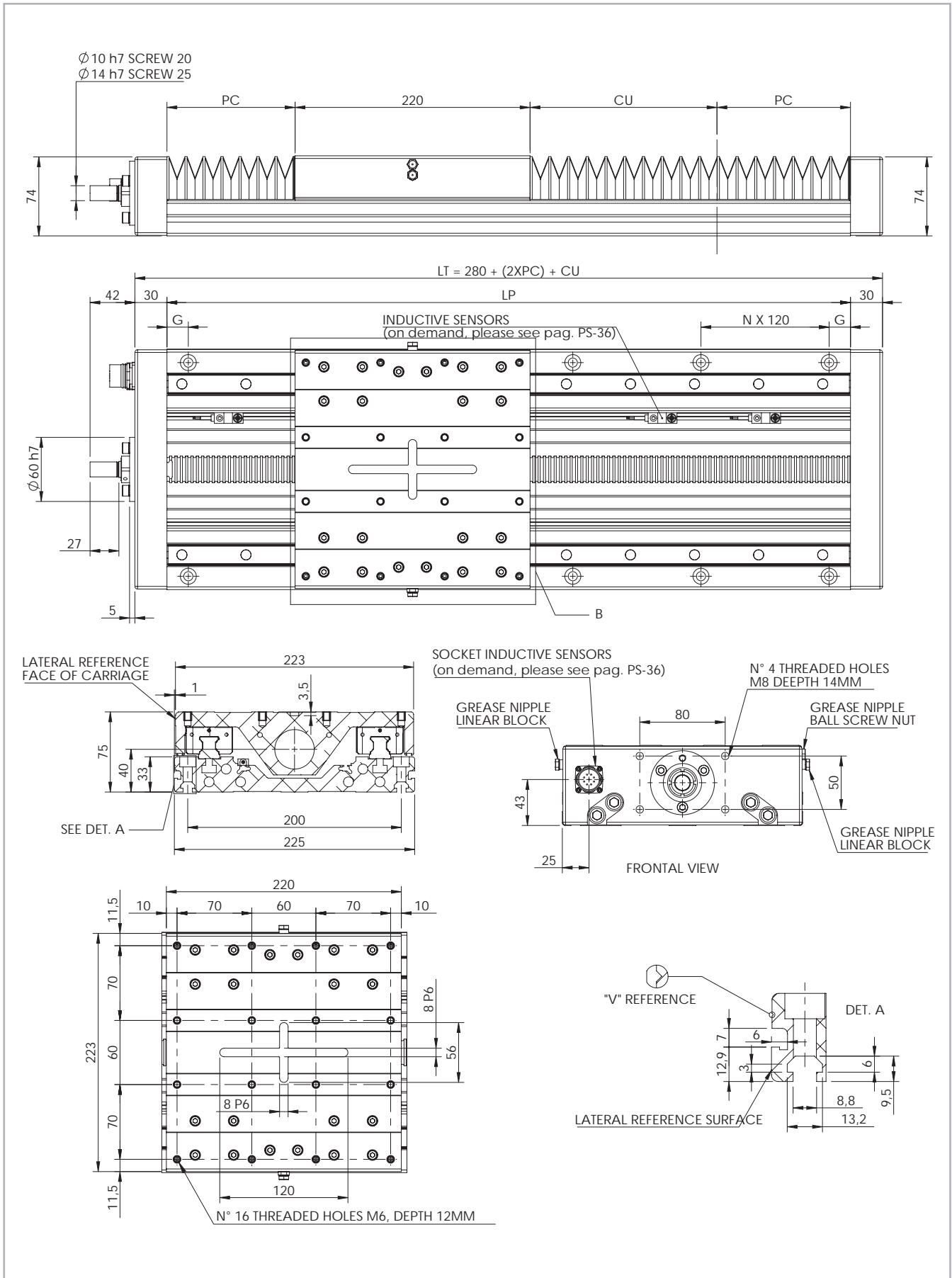

Fig. 26

Technical data

Useful stroke CU [mm]	Total length LT [mm]	G Dimension [mm]	Weight [Kg]
92	400	50	15
144	460	20	16
196	520	50	17
248	580	20	19
300	640	50	20
352	700	20	21
404	760	50	23
508	860	50	25
612	1000	50	28
714	1120	50	31
818	1240	50	33
922	1360	50	36
1026	1480	50	39
1234	1720	50	44
1440	1960	50	49
1648*	2200	50	54
1856*	2440	50	60
2062*	2680	50	65
2270*	2920	50	70

Note: for the ballscrew Ø20 the max. useful stroke is 1440 mm.

* For the indicated lengths Rollon does not guarantee the tolerance values shown on pag. PS-31

Tab. 66

Ball screw precision

Type	Max. positioning precision [mm/300mm]		Max. repeatability precision [mm]	
	ISO 5	ISO 7	ISO 5	ISO 7
TT 225 / 20-05	0.023	0.05	0.005	0.045
TT 225 / 20-20	0.023	0.05	0.005	0.045
TT 225 / 25-05	0.023	0.05	0.005	0.045
TT 225 / 25-10	0.023	0.05	0.005	0.045
TT 225 / 25-25	0.023	0.05	0.005	0.045

Tab. 67

TT 225 - Load capacity

Type	F_y [N]		F_z [N]		M_x [Nm]		M_y [Nm]		M_z [Nm]	
	Stat.	Dyn.	Stat.	Dyn.	Stat.	Dyn.	Stat.	Dyn.	Stat.	Dyn.
TT 225	86800	69600	86800	69600	6944	5568	5642	4524	5642	4524

See verification under static load and lifetime on page SL-2 and SL-3

Tab. 71

Technical data

	Type
	TT 225
Max. speed [m/s]	See page PS-33
Carriage weight [kg]	5.4

Tab. 68

Moments of inertia of the aluminum body

Type	I_x [10 ⁷ mm ⁴]	I_y [10 ⁷ mm ⁴]	I_p [10 ⁷ mm ⁴]
TT 225	0.038	2.289	2.327

Tab. 69

TT 225 - Load capacity F_x

Type	F_x [N]		
	Screw	Stat.	Dyn.
TT 225	20-05	21500	14300
	20-20	18800	13300
	25-05	27200	15900
	25-10	27000	15700
	25-25	23300	14700

Tab. 70

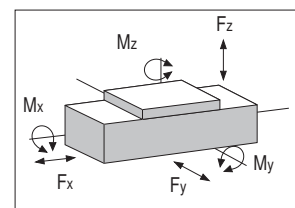

> TT 310

TT 310 Dimensions

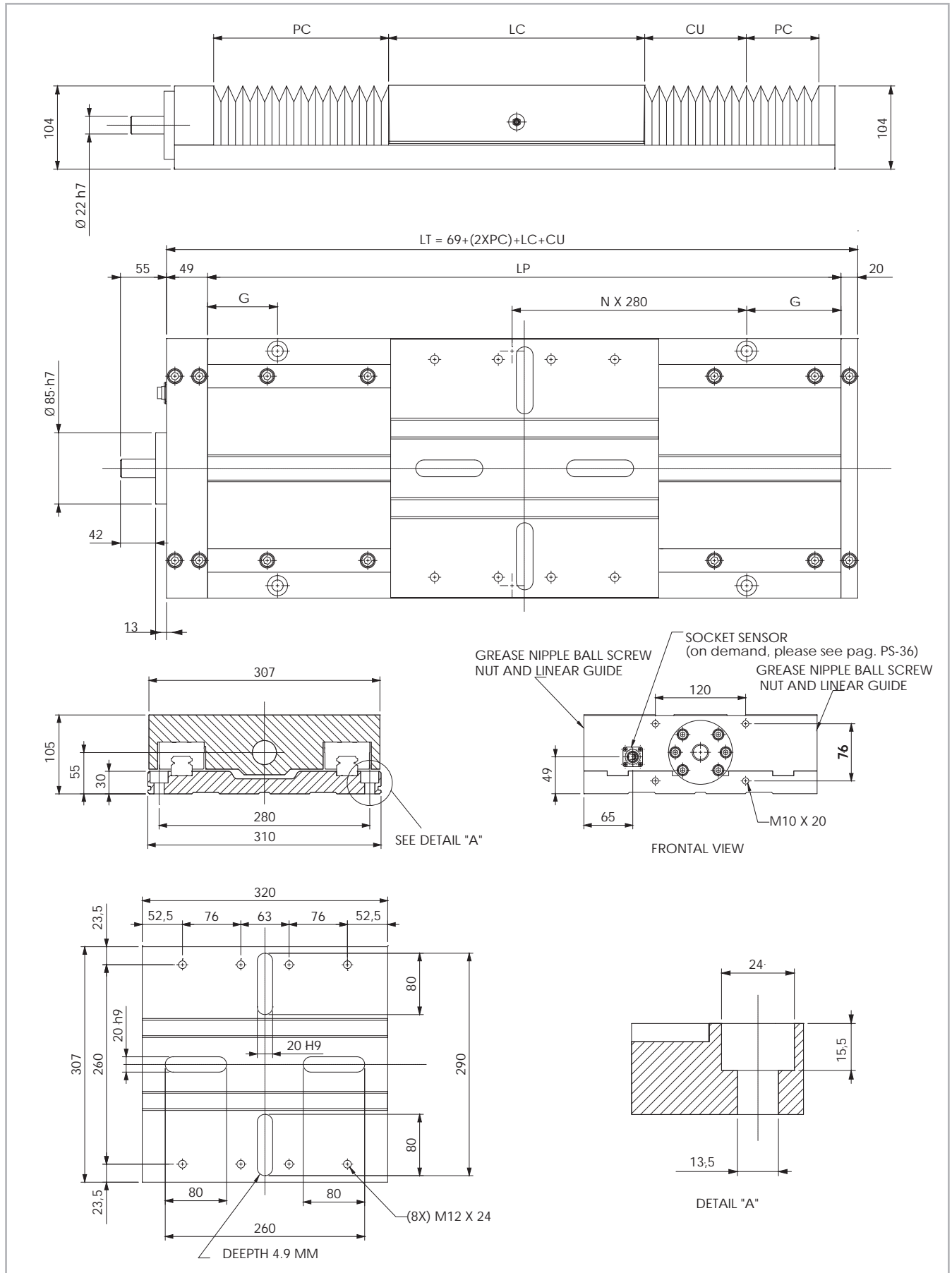

Fig. 27

Technical data

Useful stroke CU [mm]	Total length LT [mm]	G Dimension [mm]	Weight [Kg]
100	560	140	47
150	625	175.5	50
200	690	65	53
250	760	100	56
300	825	132.5	59
350	895	167.5	62
400	965	62.5	65
450	1030	95	68
500	1100	130	71
600*	1235	197.5	77
800*	1505	192.5	89
1000*	1750	175	100
1200*	2000	160	111
1600*	2495	127.5	133
2000*	2990	235	156
2400*	3485	202.5	178
3000*	4225	292.5	211

* For the indicated lengths Rollon does not guarantee the tolerance values shown on pag. PS-31 Tab. 72

Ball screw precision

Type	Max. positioning precision [mm/300mm]		Max. repeatability precision [mm]	
	ISO 5	ISO 7	ISO 5	ISO 7
TT 310 / 32-05	0.023	0.05	0.008	0.045
TT 310 / 32-10	0.023	0.05	0.008	0.045
TT 310 / 32-32	0.023	0.05	0.008	0.045

Tab. 73

TT 310 - Load capacity

Type	F_y [N]		F_z [N]		M_x [Nm]		M_y [Nm]		M_z [Nm]	
	Stat.	Dyn.	Stat.	Dyn.	Stat.	Dyn.	Stat.	Dyn.	Stat.	Dyn.
TT 310	230580	128516	274500	146041	30195	16064	26627	14166	22366	12466

See verification under static load and lifetime on page SL-2 and SL-3

Tab. 77

Technical data

	Type
	TT 310
Max. speed [m/s]	See page PS-33
Carriage weight [kg]	16.91

Tab. 74

Moments of inertia of the aluminum body

Type	I_x [10 ⁷ mm ⁴]	I_y [10 ⁷ mm ⁴]	I_p [10 ⁷ mm ⁴]
TT 310	0.060	7.048	8.008

Tab. 75

TT 310 - Load capacity F_x

Type	F_x [N]		
	Screw	Stat.	Dyn.
TT 310	32-05	40000	21600
	32-10	58300	31700
	32-32	34000	19500

Tab. 76

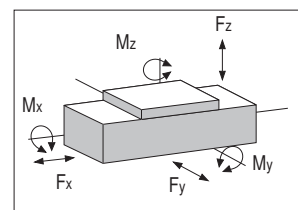

P
S

> Lubrication

SP linear units with ball bearing guides

SP Linear units are equipped with self lubricating linear ball guides. The ball bearing carriages of the SP versions are also fitted with a retention cage that eliminates "steel-steel" contact between adjacent revolving parts and prevents misalignment of these in the circuits.

Special lubrication reservoirs are mounted on the front plates of the linear blocks which continuously provide the necessary amount of grease to the

ball raceways under load. These lubrication reservoirs also considerably reduce the frequency of lubrication of the module. This system guarantees a long interval between maintenances: SP version: every 5000 km or 1 year of use, based on the value reached first. If a longer service life is required or in case of high dynamic or high loaded applications please contact our offices for further verification.

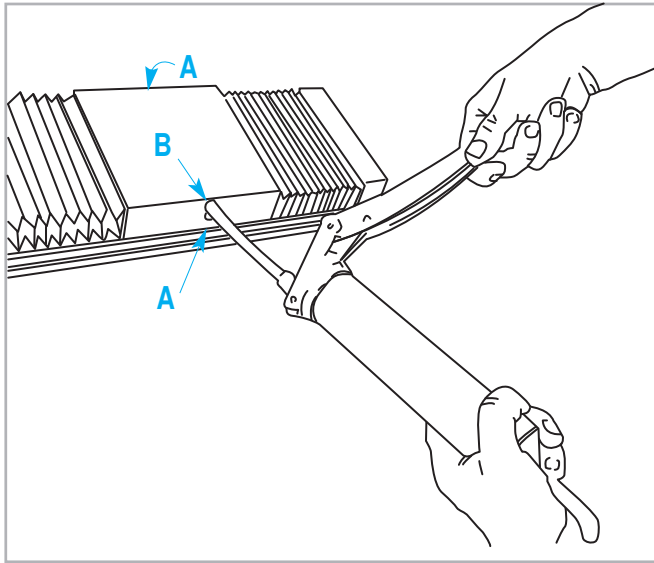

Fig. 28

- Insert the tip in the specific grease nipples:

A - Linear block - B - Ball screw nut

- Type of lubricant: Lithium soap grease of class NLGI 2.

- For specially stressed applications or difficult environmental conditions, lubrication should be carried out more frequently. Apply to Rollon for further advice.

Quantity of lubricant necessary for block re-lubrication:

Type	Quantity [g] for grease nipple
TT 100	1.4
TT 155	1.6
TT 225	2.8
TT 310	5.6

Tab. 79

Ball screws

The ball screw nuts of Rollon TT-series linear units must be relubricated every $50 \cdot 10^6$ revolutions. Therefore, using the following conversion table, according to the lead of the screw, the units must be re-lubricated when the linear travel distance (in km) indicated below has been reached.

N° turns / linear path comparison table

Turns	Lead 5	Lead 10	Lead 20	Lead 25	Lead 32
$50 \cdot 10^6$	250 km	500 km	1000 km	1250 km	1600 km

Tab. 78

Standard lubrication

Lubrication of the ball bearing blocks and the ball screw nut is facilitated by grease nipples located on the sides of the carriage of the Rollon TT series actuators. The linear units are lubricated with class NLGI2 lithium soap grease.

Amount of lubricant recommended for ball screw nut re-lubrication

Type	Quantity [g] for grease nipple
12-05	0.3
12-10	0.3
16-05	0.6
16-10	0.8
20-05	0.9
20-20	1.7
25-05	1.4
25-10	1.7
25-25	2.4
32-05	2.3
32-10	2.8
32-32	3.7

Tab. 80

> Accuracy certificate

The Rollon TT series linear units are high accurate products. The base and the carriages are made of aluminum extrusions that are manufactured by means of high precision machining of all external faces and all mounting surfaces of mechanical components (linear guides, ball screw supports, etc.). This results in excellent repeatability, positioning accuracy and running parallelism. Rollon TT series linear units are 100% tested and will be delivered with a certificate of accuracy.

The certificate shows all parallel tolerances during the movement of the carriage on the base unit. The figures can be used for eventual electronic compensations during the movement of the linear units.

The maximum deviations are shown as follows:

G1 - rolling 50 μm

G2 - pitching 50 μm

G3 - yawing 50 μm

G4 - parallelism carriage/base unit 50 μm

CERTIFICATE OF INSPECTION POSITIONING LINEAR STAGE TT SERIES	
TYPE AND MODEL	
Type	T155
Stroke	710 mm
Ball screw diam.	16 mm
Ball screw lead	5 mm
Serial rif.	N° - 0407
SPECIFICATION	
Measurement pitch	20 mm
Max error accepted on each different measurement	
G1	50 μm
G2	50 μm
G3	50 μm
G4	50 μm
TEST RESULTS	
Max error on G1	9 μm
Max error on G2	14 μm
Max error on G3	19 μm
Max error on G4	14 μm
Date	19/10/07
Temperature (C°)	(C°)20
Checked by	
Final test result:	POSITIVO
Signature	
	
ROLLON® Linear Evolution	ROLLON S.p.A. Via Trieste 26 I 20059 Vimercate (MB)
Tel.: (+39) 039 62 59 1 Fax: (+39) 039 62 59 205 E-Mail: infocom@rollon.it www.rollon.it	

Type	Screw	Fixing torques screws 12.9	
		On aluminum	On steel
TT 100	M6	10 Nm	14 Nm
TT 155	M6	10 Nm	14 Nm
TT 225	M8	15 Nm	30 Nm
TT 310	M12	60 Nm	120 Nm

Tab. 81

Note : Values for base unit length (Lt) <_ 2000 mm

These values are measured while linear unit is fixed with brackets on a reference table with parallelism error < 2 μm .

The fixing torques of the bolt must follow the indicated values in the table.

ATTENTION: The mentioned accuracy grades are valid only if the linear unit is fixed on a continuous mounting surface with the same length. The errors of the mounting surface may negatively influence the accuracy of the Rollon linear unit. Rollon does not guarantee the above mentioned parallelism tolerances for applications, when the linear unit is mounted without support or as a cantilever.

The graphs below show an example of measurement of accuracy along the stroke the deviation is given. Each actuator delivered is provided with the graphs.

Precision G1

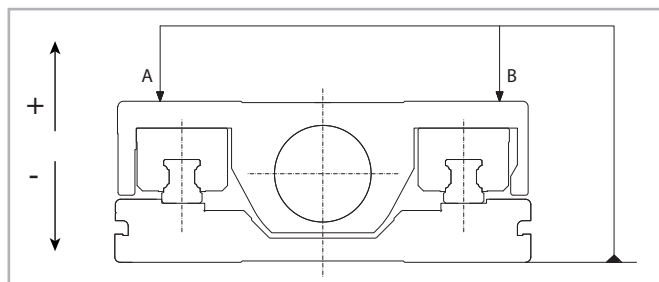
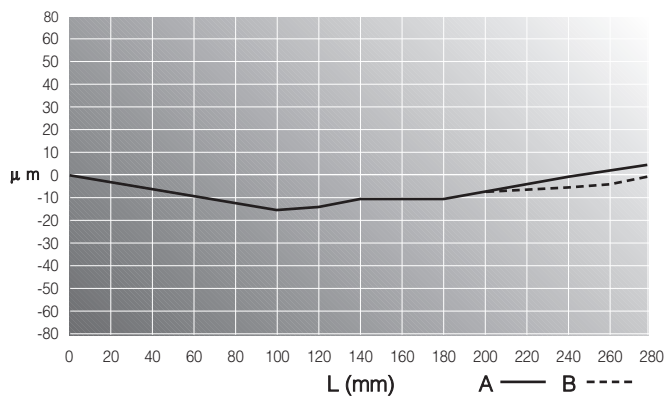

Fig. 29



Precision G2

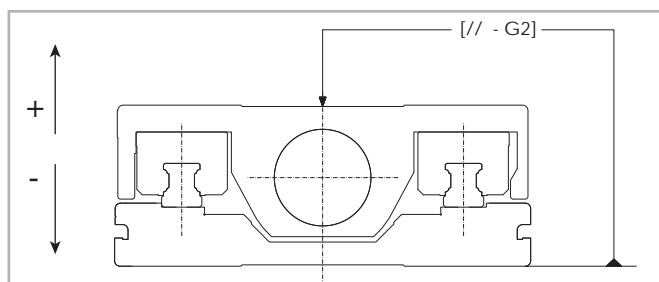
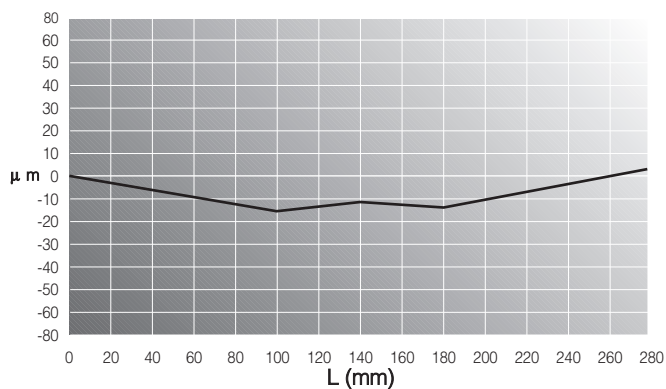

Fig. 30



Precision G3

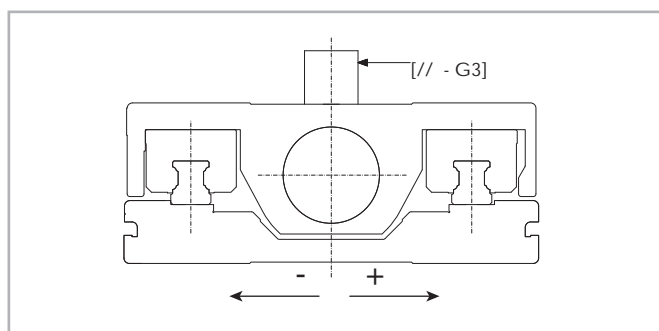
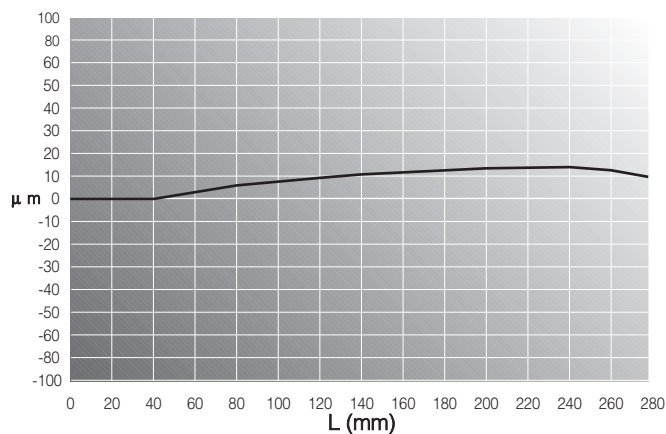

Fig. 31



Precision G4

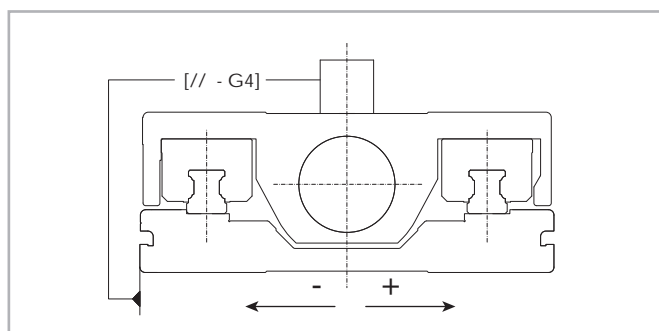
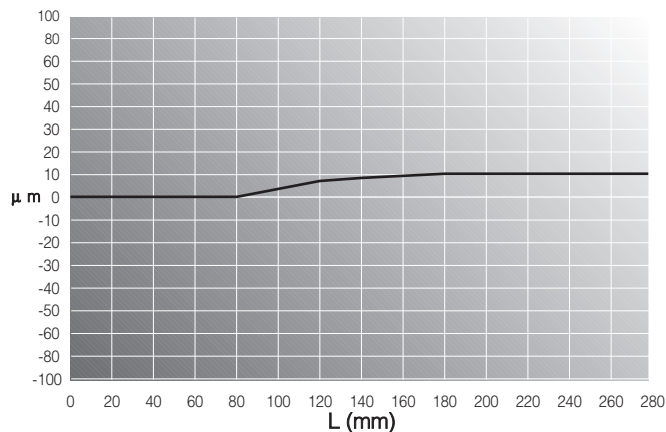

Fig. 32



> Critical speed

The maximum linear speed of Rollon TT -series linear units depends on the critical speed of the screw (based on its diameter and length) and on the max. permissible speed of the ball screw nut used. The limit speed for Rollon TT series units can be verified using the following formula:

$$V_{\max} = \frac{f}{\ell_n^2} \text{ [m/s]}$$

Tab. 82

> Calculation factors

Screw diameter and lead	Calculation factor (f)	Critical length of the screw (ℓ_n) [mm]
12-05	$0.65 \cdot 10^5$	$\ell_n = LT - \left(\frac{LT - Cu}{2} \right)$ LT = Total length Cu = Useful stroke
12-10	$1.30 \cdot 10^5$	
16-05	$1.63 \cdot 10^5$	
16-10	$3.25 \cdot 10^5$	
20-05	$2.13 \cdot 10^5$	
20-20	$8.42 \cdot 10^5$	
25-05	$2.76 \cdot 10^5$	
25-10	$5.52 \cdot 10^5$	
25-25	$13.48 \cdot 10^5$	
32-05	$3.58 \cdot 10^5$	
32-10	$7.03 \cdot 10^5$	
32-32	$22.50 \cdot 10^5$	

Tab. 83

The maximum linear speed, which depends on the ball screw nut, is indicated directly in the table below.

Screw diameter and lead	Max. linear speed of the ball screw nut [m/s]
12-05	0.5
12-10	1.0
16-05	0.5
16-10	1.0
20-05	0.5
20-20	2.0
25-05	0.5
25-10	1.0
25-25	2.5
32-05	0.4
32-10	0.8
32-32	2.5

Tab. 84

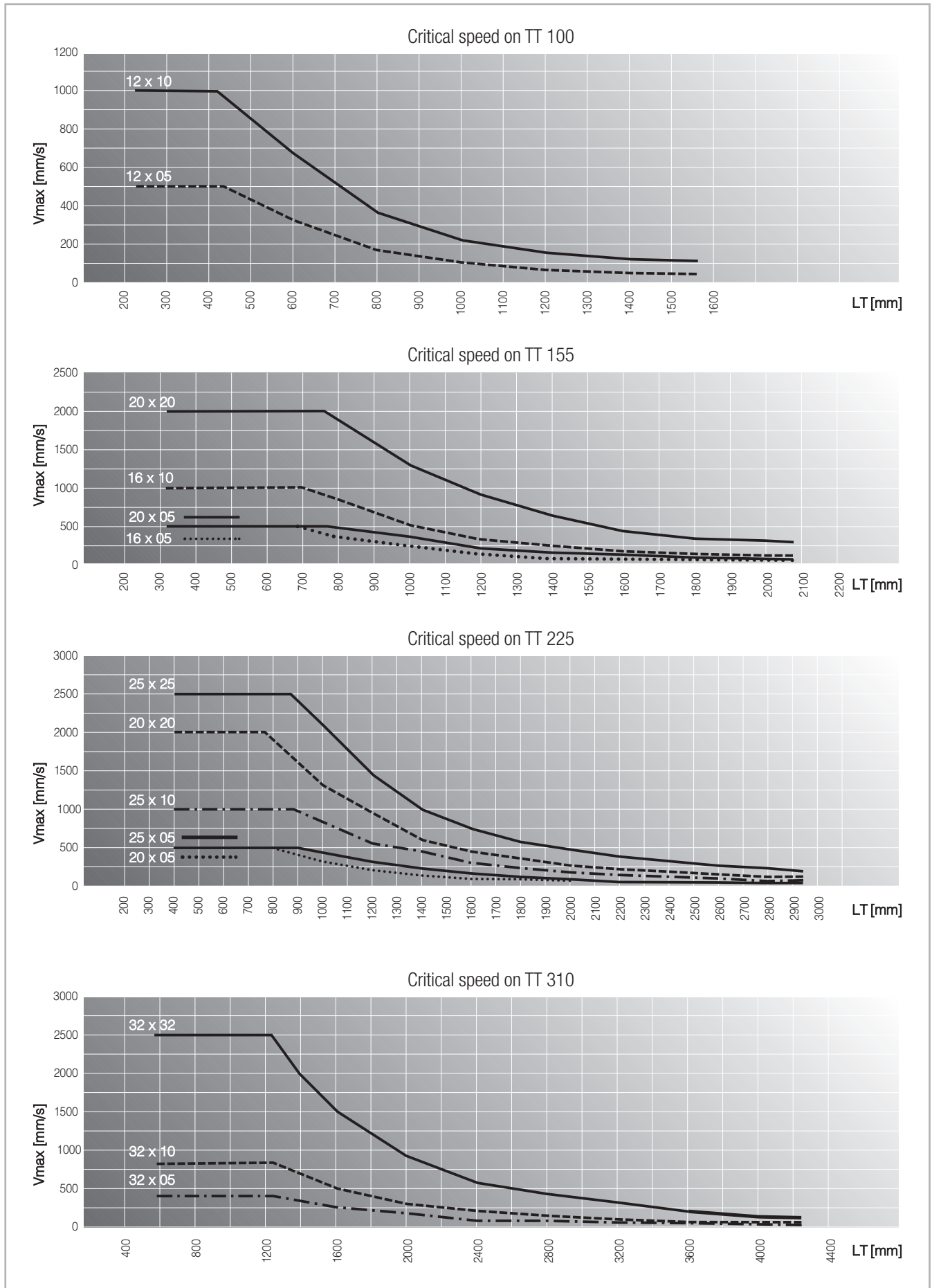

Fig. 33

> Accessories

Mounting of the motor

Rollon TT Series linear units can be supplied with different types of motor mounts, adapter flanges, and with torsionally stiff couplings for screw and motor connections that enable fast, hassle-free assembly of the motors. The types of bells available for the related units are shown in the table below:

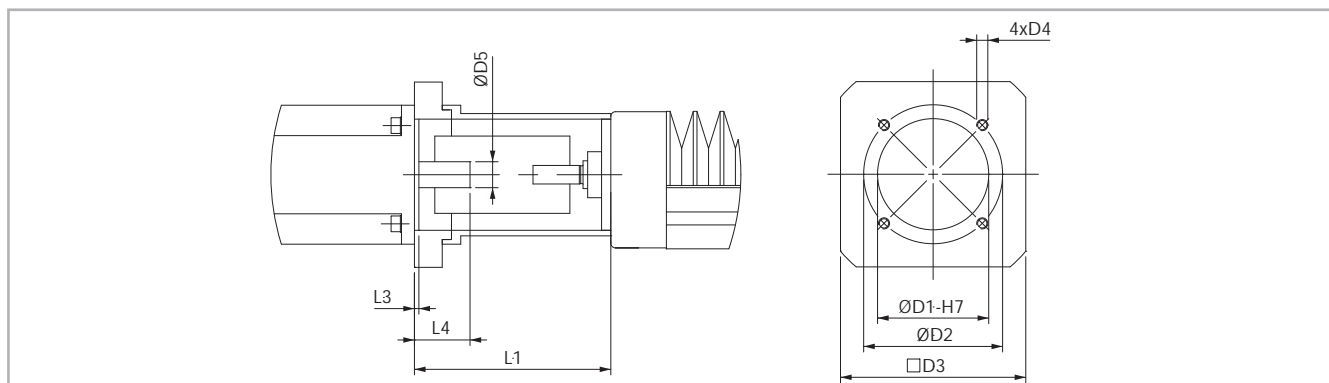

Fig. 34

Units [mm]

Type of unit	Ø D1	Ø D2	Ø D3	D4	Ø D5		L1	L3	L4		Kit code
					min.	max.			min.	max.	
TT 100	60	75	65	M6	5	16	68	4	25	27	G000321
	73.1	98.4	86	M5	5	16	76.7	2	33.7	35.7	G000322
	40	64.5	65	M5	5	16	68	4	25	27	G000336
	50	70	65	M5	5	16	77.5	3.5	34.5	36.5	G000433
TT 155	70	85	80	M6	10	20	90	4	20	34	G000311
	70	90	80	M5	10	20	90	5	20	34	G000312
	80	100	90	M6	10	20	90	4	20	34	G000313
	50	65	80	M5	10	20	90	5	20	34	G000314
	60	75	80	M6	10	20	90	4	20	34	G000315
	50	70	80	M5	10	20	90	5	20	34	G000316
	73	98.4	85	M5	10	20	90	4	20	34	G000317
	55.5	125.7	105	M6	10	20	100	5	30	44	G000318
TT 225	60	99	85	M6	10	20	98	4	28	42	G000319
	80	100	100	M6	10	28	106	5	30	48	G000302
	95	115	100	M8	10	28	106	5	30	48	G000303
	110	130	115	M8	10	28	106	5	30	48	G000304
	60	75	100	M6	10	28	106	5	30	48	G000305
	70	85	100	M6	10	28	106	5	30	48	G000306
	70	90	100	M5	10	28	106	5	30	48	G000307
	50	70	96x75	M4	10	28	101	4	30	48	G000308
	55.5	125.7	105	M6	10	28	106	5	30	48	G000309
TT 310	73.1	98.4	96	M5	10	28	101	3	30	48	G000310
	130	165	150	M10	10	28	106	5	30	48	G000363
TT 310	Option										

Tab. 85

Fixing by brackets

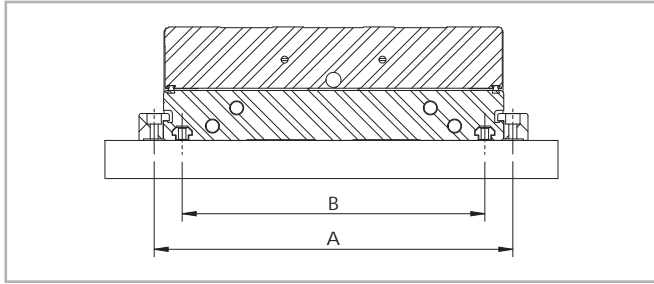

Fig. 35

Type	A Unit mm	B Unit mm
TT 100	112	59
TT 155	167	135
TT 225	237	200

Tab. 89

Fixing brackets

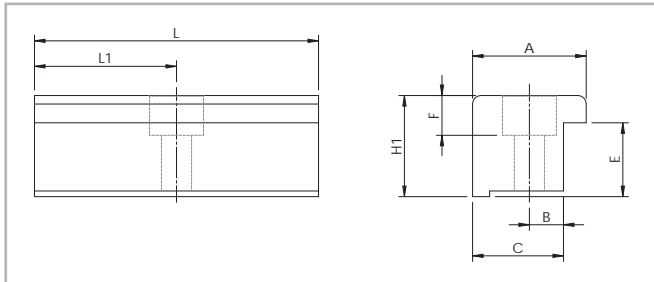

Fig. 36

Type	A	B	C	E	F	D1	D2	H1	L	L1	Code Rollon
TT 100	18.5	6	16	7	4.5	9.5	5.3	9.8	50	25	1002353
TT 155	20	6	16	11	7	9.5	5.3	15.8	50	25	1002167
TT 225	20	6	16	13	7	9.5	5.3	17.8	50	25	1002354

Tab. 90

T nuts

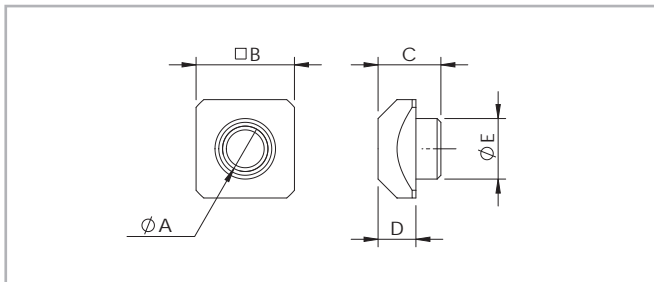

Fig. 37

Type	Ø A	B	C	D	Ø E	Code Rollon
TT 100	M4	8	-	3.4	-	1001046
TT 155	M5	10	6.5	4.2	6.7	1000627
TT 225	M6	13	8.3	5	8	1000043

Tab. 91

Proximity	Type	PNP-NO	PNP-NC
	TT 100	G000192	G000475
	TT 155	G000192	G000475
	TT 225	G000192	G000475
	TT 310	/	/

Tab. 86

End cap	Type	Code
	TT 100	G000245
	TT 155	G000244
	TT 225	G000244
	TT 310	/

Tab. 92

Cable Strain Relief	Type	Code
	TT 100	G000249
	TT 155	G000248
	TT 225	G000248
	TT 310	/

Tab. 87

9 Pin Fixed Connector	Type	Code
	TT 100	G000191
	TT 155	G000191
	TT 225	G000191
	TT 310	/

Tab. 93

9 Pin Back-Shell Connector	Type	To crimp	To solder
	TT 100	6000516	6000589
	TT 155	6000516	6000589
	TT 225	6000516	6000589
	TT 310	/	/

Tab. 88

Assembly kits

The Rollon TT series linear units must be mounted to the application's surface in an appropriate way in order to achieve maximum accuracy of the system. The evenness of the mounting surface determines the final result of the movement of the system. The aluminum base and the carriage of the Rollon TT linear units have a lateral reference surface, indicated by a groove (except on the TT 310). On the carriage's surface are two reference slots at 90° angles, useful for accurate mounting of

X-Y-systems. The Rollon TT series linear units can be fixed to the mounting surface from above the base unit by screws (fig. 38), through T-slots (fig. 39), or through appropriate mounting brackets (fig. 40), depending on the application. For high accuracy applications, Rollon recommends bolting the unit down from above. For mounting dimensions please refer to the dimensional drawings of the units.

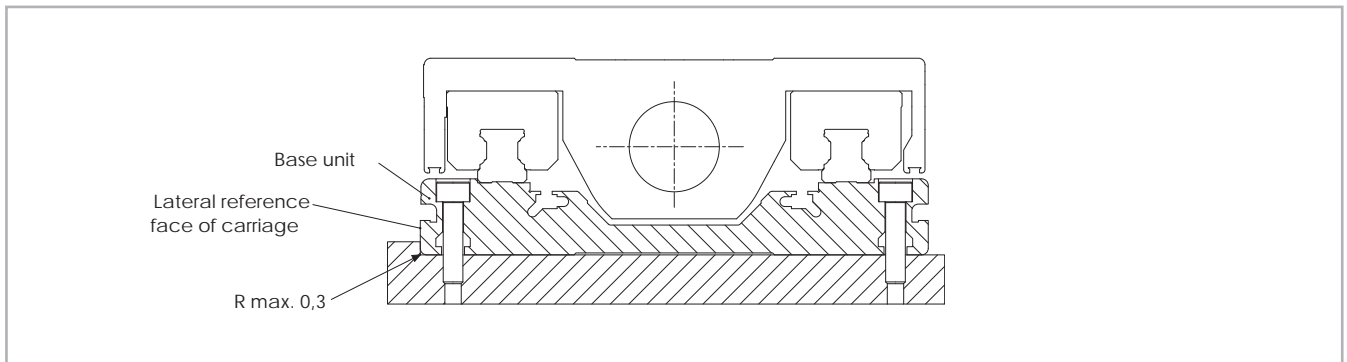

Fig. 38

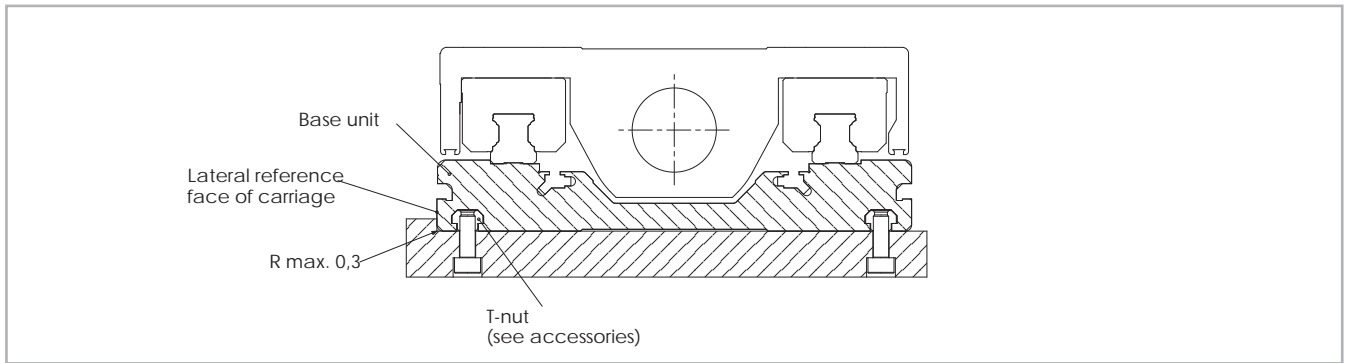

Fig. 39

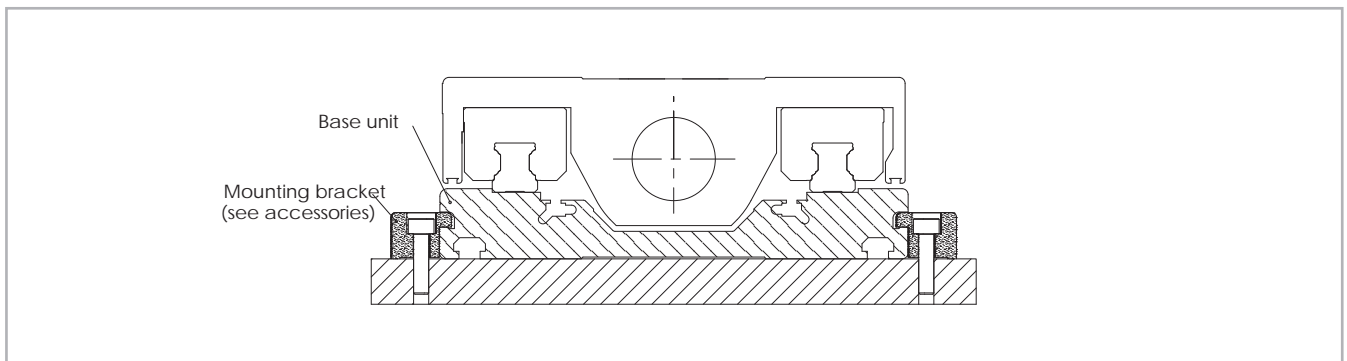

Fig. 40

Ordering key

> Identification code for the TT linear units

T	10	1205	5P	0880	1A	
	10=100	12-05	5P=ISO 5			
	15=155	12-10	7N=ISO 7			
	22=225	16-05				
	31=310	16-10				
		20-05				
		20-20				
		25-05				
		25-10				
		25-25				
		32-05				
		32-10				
		32-32				
			Type	see from pg. PS-22 to pg. PS-29		
			B/S diameter and lead	see from pg. PS-22 to pg. PS-29		
			Size	see from pg. PS-22 to pg. PS-29		
			Linear unit series TT	see pg. PS-20		

In order to create identification codes for Actuator Line, you can visit: <http://configureactuator.rollon.com>

TV series



> TV series description

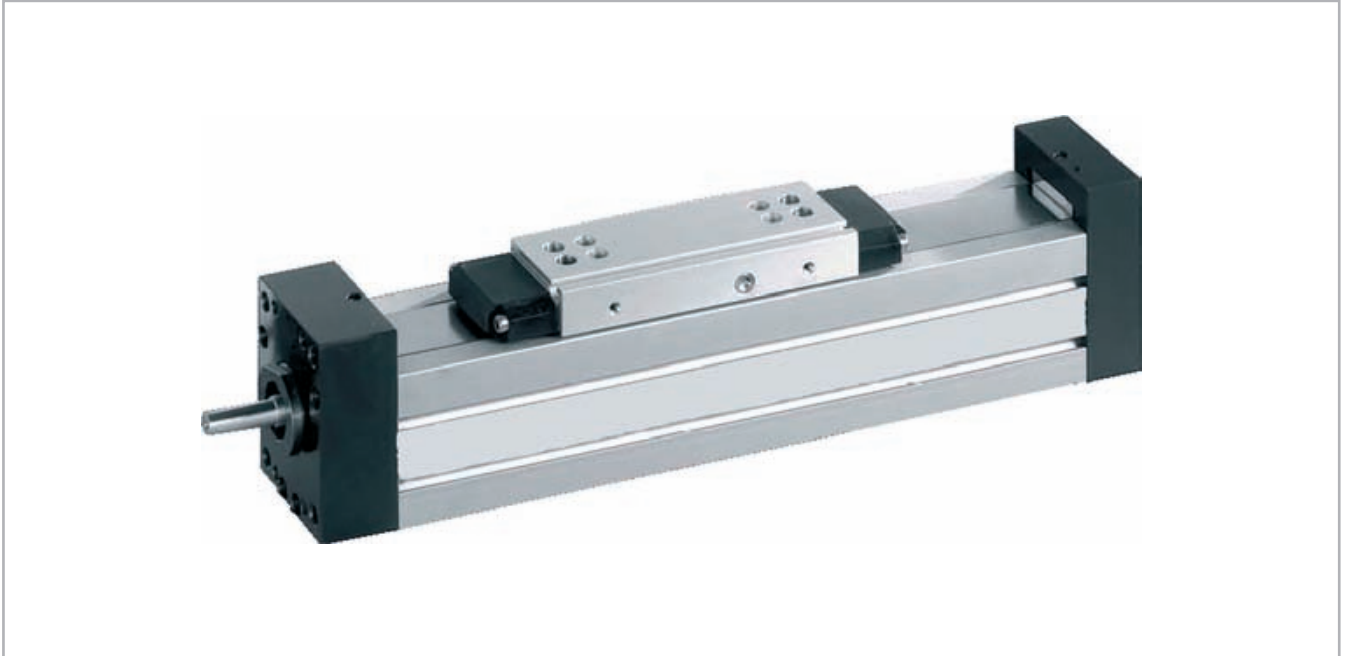

Fig. 41

TV

TV series linear units have a rigid anodized aluminum extrusion with a square cross-section (rectangular in the case of the TV 140). Transmission of motion is achieved by means of a precision C5 or C7 rolled ball screw drive.

The payload is supported by a dual block, single linear guide system (a dual block/dual guide system for TV 140) which ensures high precision and high rigidity.

> The components

Extruded bodies

The anodized aluminum extrusions used for the bodies of the Rollon TV series linear units were designed and manufactured in cooperation with a leading company in this field to obtain the accuracy and high mechanical properties necessary to accommodate the bending and torsional stresses. Aluminum alloy 6060 was used and was extruded with dimensional tolerances complying with EN 755-9 standards. T-slots are provided in the side and bottom faces to facilitate mounting.

Drive system

Rollon TV series linear units use a precision rolled ball screw. The standard precision class of the ball screw used is ISO 7 without a preloaded nut. ISO 5 precision class with preloaded nut is available upon request. The ball screws of linear units can be supplied with different diameter and leads. Use of this type of technology makes it possible to obtain the following features:

- High speed (for long pitch screws)
- Highly accurate thrust
- Superior mechanical performance
- Reduced wear
- Low resistance to movement

General data about aluminum used: AL 6060

Chemical composition [%]

Al	Mg	Si	Fe	Mn	Zn	Cu	Impurities
Remainder	0.35-0.60	0.30-0.60	0.30	0.10	0.10	0.10	0.05-0.15

Tab. 94

Physical characteristics

Density	Coeff. of elasticity	Coeff. of thermal expansion (20°-100°C)	Thermal conductivity (20°C)	Specific heat (0°-100°C)	Resistivity	Melting point
$\frac{\text{kg}}{\text{dm}^3}$	$\frac{\text{kN}}{\text{mm}^2}$	$\frac{10^{-6}}{\text{K}}$	$\frac{\text{W}}{\text{m} \cdot \text{K}}$	$\frac{\text{J}}{\text{kg} \cdot \text{K}}$	$\Omega \cdot \text{m} \cdot 10^{-9}$	°C
2.7	69	23	200	880-900	33	600-655

Tab. 95

Mechanical characteristics

Rm	Rp (02)	A	HB
$\frac{\text{N}}{\text{mm}^2}$	$\frac{\text{N}}{\text{mm}^2}$	%	—
205	165	10	60-80

Tab. 96

> TV 80

TV 80 Dimensions

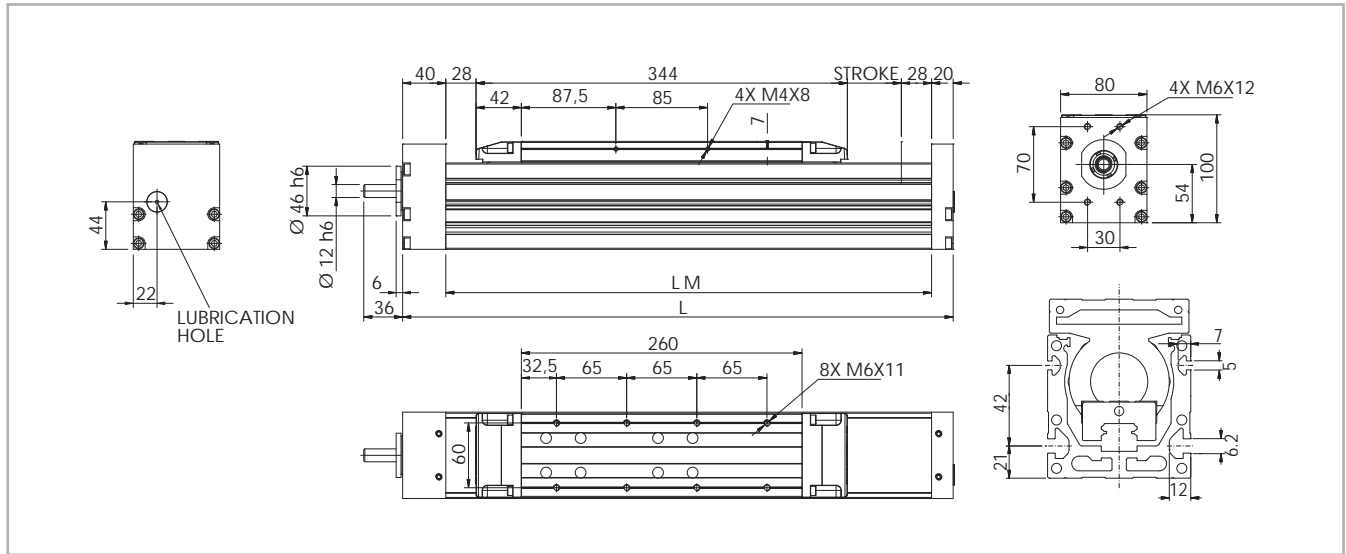

Fig. 43

Technical data

	Type
	TV 80
Max. useful stroke length [mm]	3000
Max. speed [m/s]	See page PS-46
Basement length LM [mm]	LT - 60
Total length LT [mm]	Stroke + 460
Zero travel weight [kg]	7.8
Weight for 100 mm useful stroke [kg]	0.95

Tab. 102

Moments of inertia of the aluminum body

Type	I_x [10 ⁷ mm ⁴]	I_y [10 ⁷ mm ⁴]	I_p [10 ⁷ mm ⁴]
TV 80	0.106	0.152	0.258

Tab. 104

Ball screw precision

Type	Max. positioning precision [mm/300mm]		Max. repeatability precision [mm]	
	ISO 5	ISO 7	ISO 5	ISO 7
TV 80 / 20-05	0.023	0.05	0.01	0.05
TV 80 / 20-20	0.023	0.05	0.01	0.05

Tab. 103

TV 80 - Load capacity F_x

Type	F_x [N]		
	Screw	Stat.	Dyn.
TV 80	20-05	21500	14300
	20-20	18800	13300

Tab. 105

TV 80 - Load capacity

Type	F_y [N]		F_z [N]		M_x [Nm]		M_y [Nm]		M_z [Nm]	
	Stat.	Dyn.	Stat.	Dyn.	Stat.	Dyn.	Stat.	Dyn.	Stat.	Dyn.
TV 80	29610	16344	35250	18573	320	169	1827	963	1535	847

See verification under static load and lifetime on page SL-2 and SL-3

Tab. 106

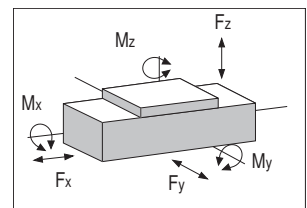

> TV 110

TV 110 Dimensions

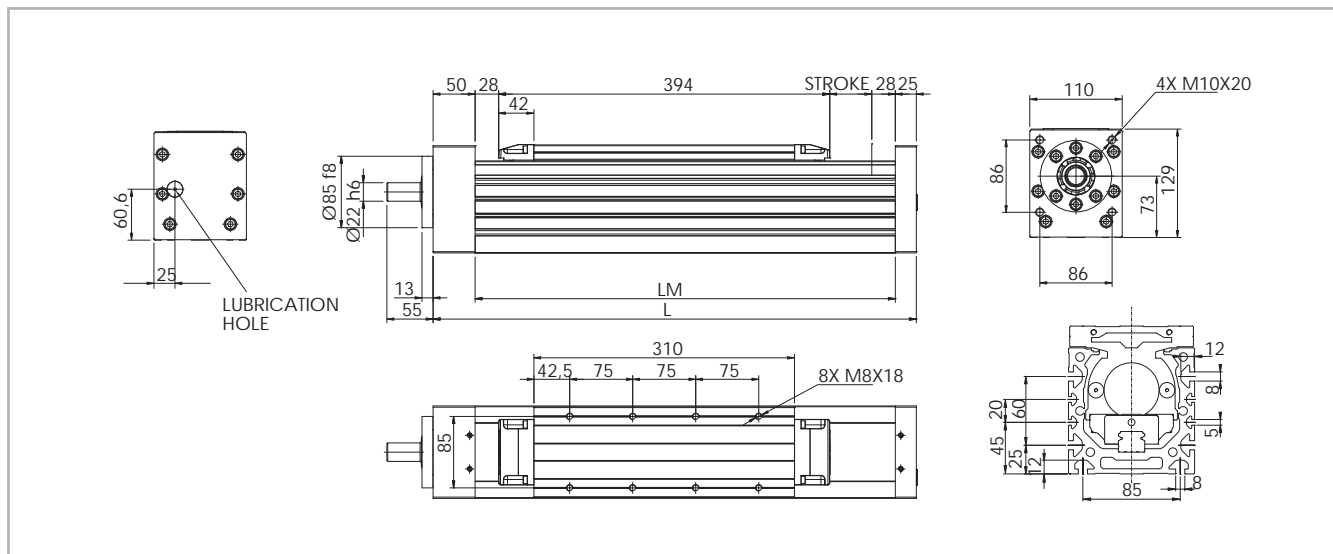

Fig. 44

Technical data

	Type
	TV 110
Max. useful stroke length [mm]	3000
Max. speed [m/s]	See page PS-46
Basement length LM [mm]	LT - 75
Total length LT [mm]	Stroke + 525
Zero travel weight [kg]	16.8
Weight for 100 mm useful stroke [kg]	1.9

Tab. 107

Moments of inertia of the aluminum body

Type	I_x [10 ⁷ mm ⁴]	I_y [10 ⁷ mm ⁴]	I_p [10 ⁷ mm ⁴]
TV 110	0.432	0.594	1.026

Tab. 109

Ball screw precision

Type	Max. positioning precision [mm/300mm]		Max. repeatability precision [mm]	
	ISO 5	ISO 7	ISO 5	ISO 7
TV 110 / 32-05	0.023	0.05	0.01	0.05
TV 110 / 32-10	0.023	0.05	0.01	0.05
TV 110 / 32-32	0.023	0.05	0.01	0.05

Tab. 108

TV 110 - Load capacity F_x

Type	F_x [N]		
	Screw	Stat.	Dyn.
TV 110	32-05	40000	21600
	32-10	58300	31700
	32-32	34000	19500

Tab. 110

TV 110 - Load capacity

Type	F_y [N]		F_z [N]		M_x [Nm]		M_y [Nm]		M_z [Nm]	
	Stat.	Dyn.	Stat.	Dyn.	Stat.	Dyn.	Stat.	Dyn.	Stat.	Dyn.
TV 110	45990	26262	54750	29843	572	312	3477	1895	2920	1668

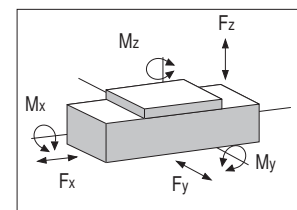

See verification under static load and lifetime on page SL-2 and SL-3

Tab. 111

> TV 140

TV 140 Dimensions

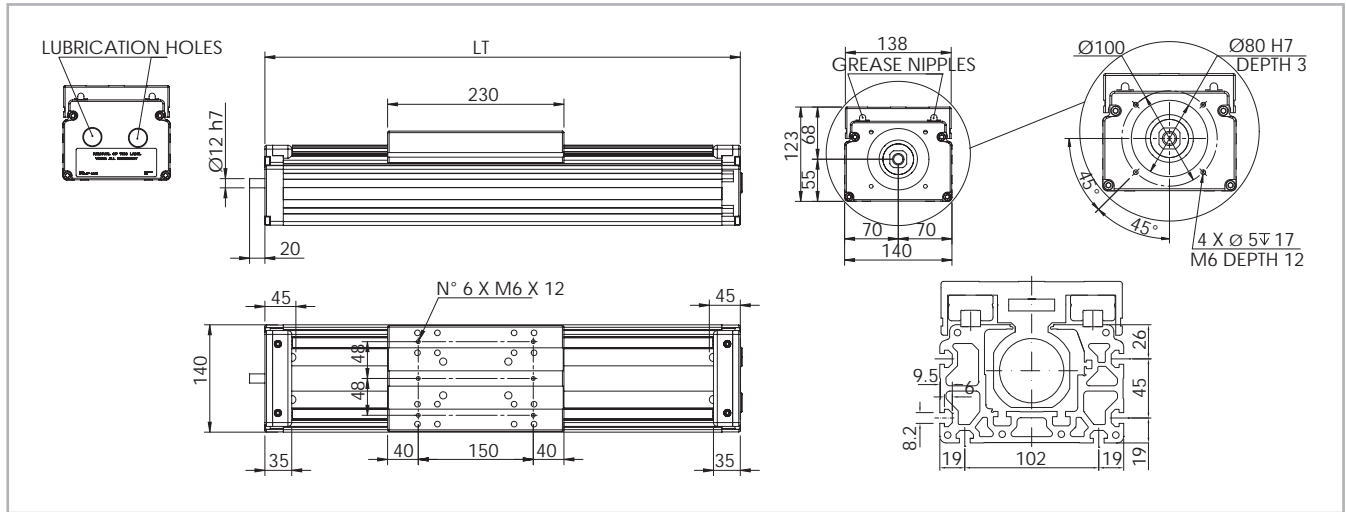

Fig. 45

Technical data

	Type
	TV 140
Max. useful stroke length [mm]	4000
Max. speed [m/s]	See page PS-46
Basement length LM [mm]	LT - 70
Total length LT [mm]	Stroke + 320
Zero travel weight [kg]	10.7
Weight for 100 mm useful stroke [kg]	2.5

Tab. 112

Moments of inertia of the aluminum body

Type	I_x [10 ⁷ mm ⁴]	I_y [10 ⁷ mm ⁴]	I_p [10 ⁷ mm ⁴]
TV 140	0.937	2.465	3.402

Tab. 114

Ball screw precision

Type	Max. positioning precision [mm/300mm]		Max. repeatability precision [mm]	
	ISO 5	ISO 7	ISO 5	ISO 7
TV 140 / 20-05	0.023	0.05	0.01	0.05
TV 140 / 20-20	0.023	0.05	0.01	0.05
TV 140 / 25-05	0.023	0.05	0.01	0.05
TV 140 / 25-25	0.023	0.05	0.01	0.05

Tab. 113

TV 110 - Load capacity F_x

Type	F_x [N]		
	Screw	Stat.	Dyn.
TV 140	20-05	21500	14300
	20-20	18800	13300
	25-05	27200	15900
	25-25	23300	14700

Tab. 115

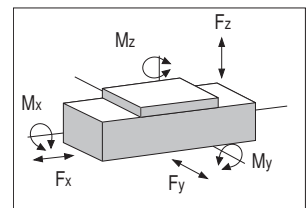

TV 140 - Load capacity

Type	F_y [N]		F_z [N]		M_x [Nm]		M_y [Nm]		M_z [Nm]	
	Stat.	Dyn.	Stat.	Dyn.	Stat.	Dyn.	Stat.	Dyn.	Stat.	Dyn.
TV 140	48400	29120	48400	29120	2251	1354	3049	1835	3049	1835

See verification under static load and lifetime on page SL-2 and SL-3

Tab. 116

> Lubrication

TV 60, TV 80, TV 110 linear units

Rollon TV-series linear units are equipped with ball bearing guides lubricated with grease lithium soap based grade 2. Re-lubrication is required every 3-6 months or approximately 100 km of linear travel. The application environment and applied loads may influence the re-lubrication periods.

TV 140 linear units

SP Linear units are equipped with self lubricating linear ball guides. The ball bearing carriages of the SP versions are also fitted with a retention cage that eliminates "steel-steel" contact between adjacent

revolving parts and prevents misalignment of these in the circuits. Special lubrication reservoirs are mounted on the front plates of the linear blocks which continuously provide the necessary amount of grease to the ball raceways under load. These lubrication reservoirs also considerably reduce the frequency of lubrication of the module. This system guarantees a long interval between maintenances: SP version: every 5000 km or 1 year of use, based on the value reached first. If a longer service life is required or in case of high dynamic or high loaded applications please contact our offices for further verification.

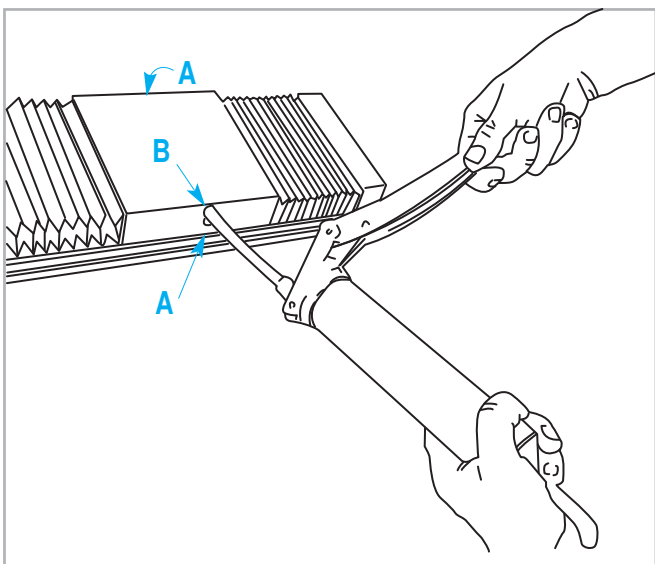

Fig. 46

- Insert the tip of the oil can in the specific grease nipples:
A - Linear block - B - Ball screw nut
- Type of lubricant: Lithium soap grease of class NLGI 2.
- For specially stressed applications or difficult environmental conditions, lubrication should be carried out more frequently.
Apply to Rollon for further advice.

Quantity of lubricant necessary for block re-lubrication:

Type	Quantity [g] of grease for each nipple
TV 60	1.4
TV 80	2.6
TV 110	5.0
TV 140	1.3

Tab. 118

Ball screws

The ball screw nuts of Rollon TV-series linear units must be re-lubricated every $50 \cdot 10^6$ revolutions. Therefore, using the following conversion table, according to the pitch of the screw, the units must be re-lubricated when the linear travel distance (in km) indicated above has been reached.

Grease Nipples position

The position of grease nipples for the linear blocks and for the ball screw nuts are indicated in the specific drawings of each product.

N° turns / linear path comparison table

Turns	Lead 5mm	Lead 10mm	Lead 16mm	Lead 20mm	Lead 25mm	Lead 32mm
$50 \cdot 10^6$	250 km	500 km	800 km	1000 km	1250 km	1600 km

Tab. 117

Amount of lubricant recommended for ball screw nut re-lubrication

Type	Quantity [g] for grease nipple
16-05	0.6
16-10	0.8
16-16	1.0
20-05	0.9
20-20	1.7
25-05	1.4
25-25	2.4
32-05	2.3
32-10	2.8
32-32	3.7

Tab. 119

> Critical speed

The maximum linear speed of Rollon TV series linear units depends on the critical speed of the screw (based on its diameter and length) and on the max. permissible speed of the ball screw nut used. The limit speed for Rollon TV series units can be verified using the following formula:

$$V_{\max} = \frac{f}{\ell_n^2} \text{ [m/s]}$$

Tab. 120

> Calculation factors

Screw diameter and lead	Calculation factor (f)	Critical length of the screw (ℓ_n)
16-05	$1.63 \cdot 10^5$	$\ell_n = LT - \left(\frac{LT - Cu}{2} \right)$ LT = Total length Cu = Useful stroke
16-10	$3.25 \cdot 10^5$	
16-16	$5.20 \cdot 10^5$	
20-05	$2.13 \cdot 10^5$	
20-20	$8.42 \cdot 10^5$	
25-05	$2.76 \cdot 10^5$	
25-25	$13.48 \cdot 10^5$	
32-05	$3.58 \cdot 10^5$	
32-10	$7.03 \cdot 10^5$	
32-32	$22.50 \cdot 10^5$	

Tab. 121

The maximum linear speed, which depends on the ball screw nut, is indicated directly in the table below.

Screw diameter and lead	Max. linear speed of the ball screw nut [m/s]
16-05	0.5
16-10	1.0
16-16	1.6
20-05	0.5
20-20	2.0
25-05	0.5
25-25	2.5
32-05	0.4
32-10	0.8
32-32	2.5

Tab. 122

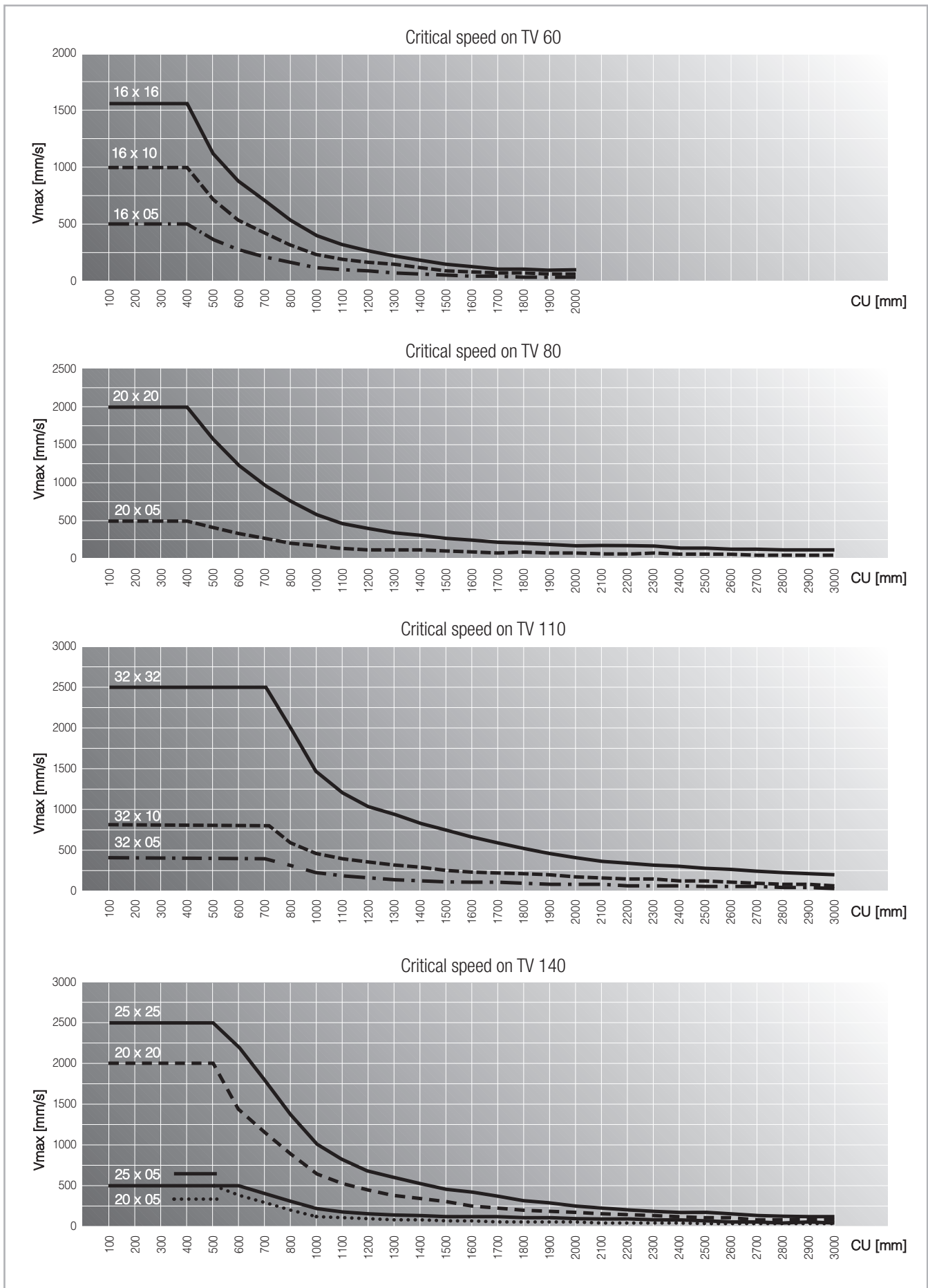

Fig. 47

> Accessories

Fixing by brackets

The linear motion systems used for the Rollon TV series linear units enables them to support loads in any direction. They can therefore be installed in any position. To install the units, we recommend the use of the dedicated slots in the extruded bodies as shown below.

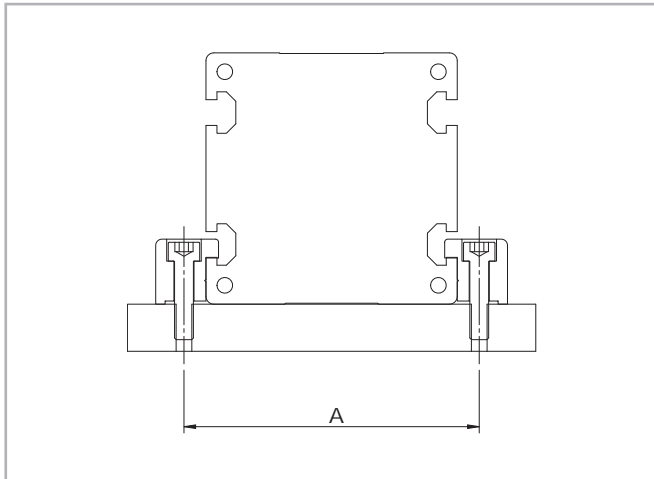

Fig. 48

Type	A [mm]
TV 60	77
TV 80	94
TV 110	130
TV 140	154

Tab. 123

Warning: Do not secure the linear units by means of the T-slots in the Drive head or Idle head at either end of the actuator.

Fixing bracket

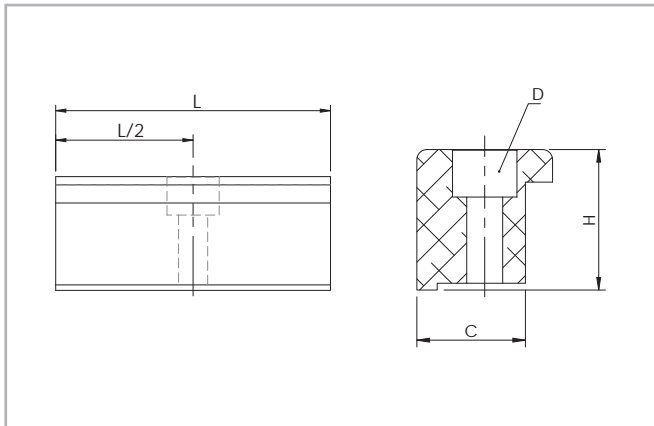

Fig. 49

Dimensions / Unit [mm]

Type	C	H	L	D	Code Rollon
TV 60	16	19.5	35	M5	1002358
TV 80	16	22.5	50	M6	1004552
TV 110	31	27	100	M10	1002360
TV 140	16	22	50	M6	1001491

Tab. 124

Anodized aluminum block for fixing the linear units through the side slots of the body.

T-nuts

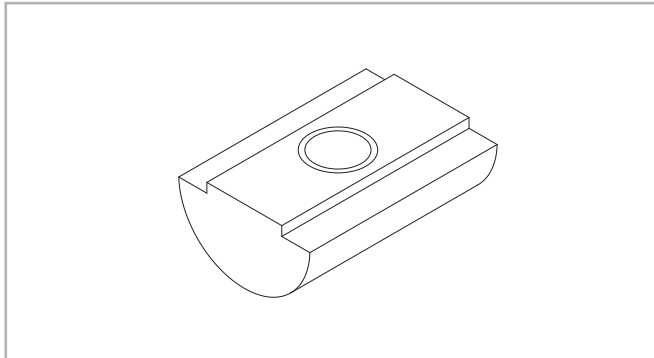

Fig. 50

Code Rollon

Slot	M5	M6	M8
5	6001038	-	-
6.2	-	6001863	-
8	-	6001044	6001045
8.2	-	1000043	-

Steel nuts to be used in the slots of the body.

Tab. 125

Proximity

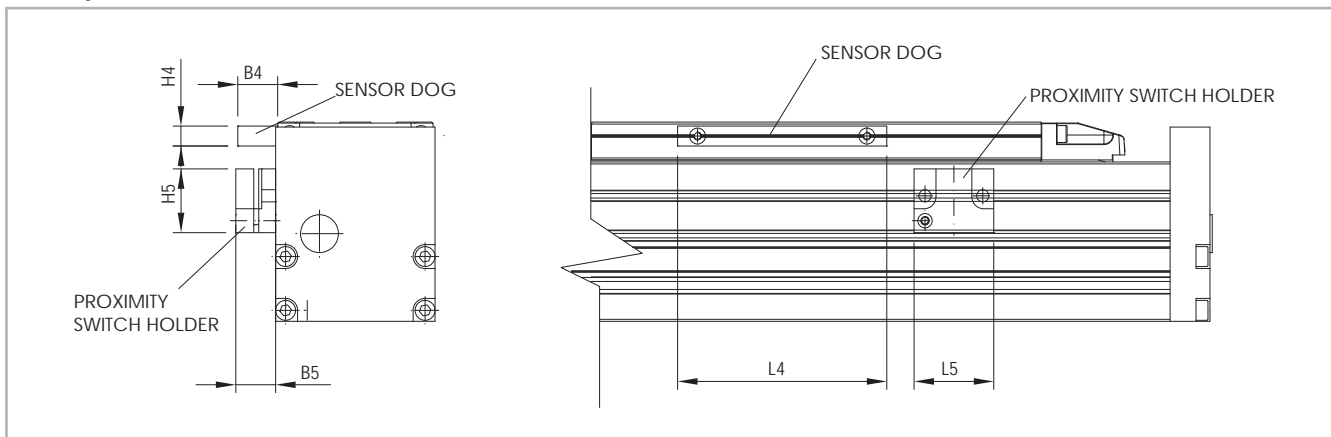

Fig. 51

Proximity switch holder

Red anodized aluminum block, equipped with T-nuts for fixing into the body slots.

Sensor dog

Zinc-plated steel plate, mounted on the carriage and used for the proximity switch operation.

Unit [mm]

	B4	B5	L4	L5	H4	H5	Sensor	Proximity holder set	Sensor dog
TV 60	20	20	105	40	10	32	Ø12	G000849	G000581
TV 80	20	20	105	40	10	32	Ø12	G000849	G000581
TV 110	20	20	105	40	10	32	Ø12	G000850	G000581
TV 140	21	20	50	40	20	32	Ø12	G000209	G000269

Tab. 126

Ordering key 

> **Identification code for the TV linear units**

V	06	1605	5P	0800	1A	
	06=60	16-05	5P=ISO 5			
	08=80	16-10	7N=ISO 7			
	11=110	16-16				
	14=140	20-05				
		20-20				
		25-05				
		25-25				
		32-05				
		32-10				
		32-32				
					L=total length of th unit	
					Type see from pg. PS-39 to pg. PS-42, tab. 100, 105, 110, 115	
				B/S diameter and lead		
				Size see from pg. PS-39 to pg. PS-42		
				Linear unit series TV see pg. PS-37		

In order to create identification codes for Actuator Line, you can visit: <http://configureactuator.rollon.com>

TK series

**> TK series description**

Fig. 52

The 'TK' series linear units are made entirely of steel which allows for high load capacity and high precision positioning and repeatability with very compact dimensions. This series can be dimensionally interchanged with other popular ball screw driven actuators.

All mounting surfaces and references are adjusted so as to ensure a high degree of dimensional accuracy. The high load capacity and position repeatability of the TK series is achieved with a ball screw transmission.

> The components

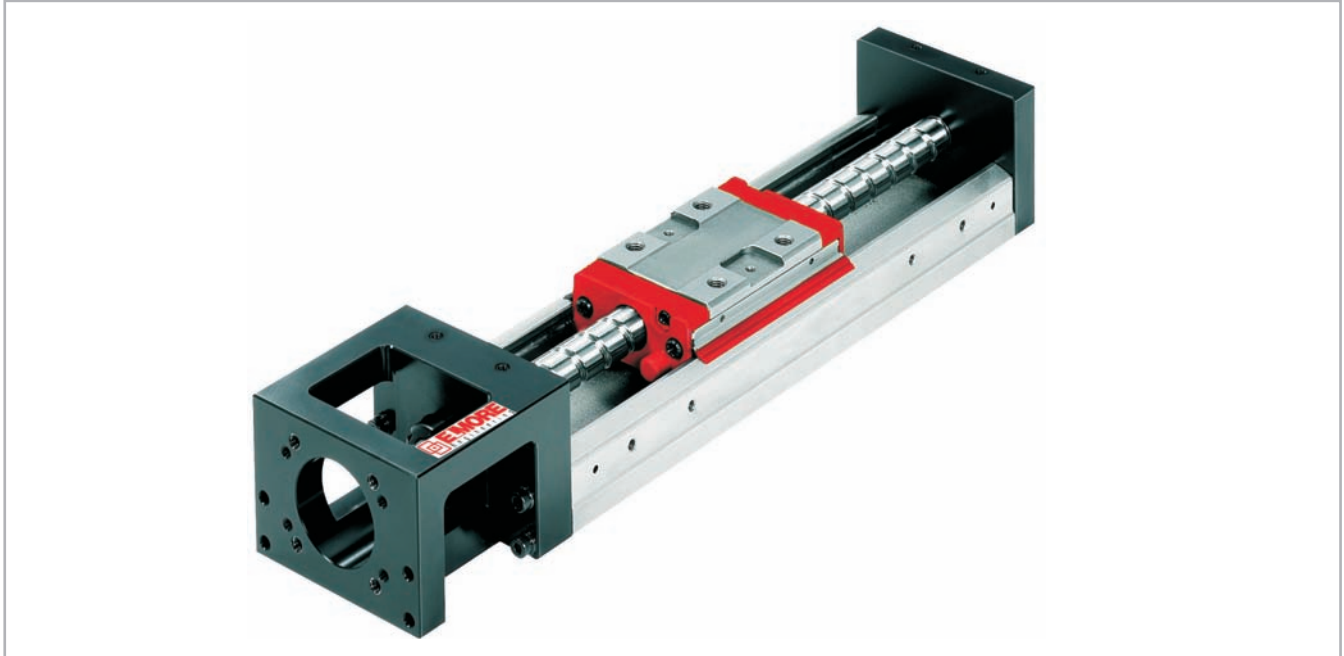
The steel profile

The profile of Rollon TK series linear unit is made by a hot drawn bearing grade steel. The ball grooves are located on the inner side of the U shaped steel profile. These grooves are hardened and grinded in order to obtain a high accuracy running parallelism similar to a ball bearing linear guide.

Drive system

The standard precision class is ISO 5 with a light preload. ISO 7 is available with a controlled clearance upon request. The ball screws of the linear units can be supplied with different diameter and leads. Use of this technology makes it possible to obtain the following features:

- High stiffness and compact system
- High load capacity and thrust force
- Superior mechanical performance
- Reduced wear
- Low resistance to movement

Carriage

The carriage of Rollon TK series linear units is made from the same steel alloy as the profile. The carriage combines the functions of both a linear bearing as well as a ball nut in one unit. The body is hardened and ground on the ball grooves of the nut and on the ball grooves of the linear block.

Protection

Rollon TK series linear units are equipped with front and lateral seals in order to protect the carriage and the nut during operation of the guide on the ball screw. High temperature resistant bellows are mounted upon request for Rollon TK series linear units, except on the TK 40.

> TK 40

TK 40 Dimensions

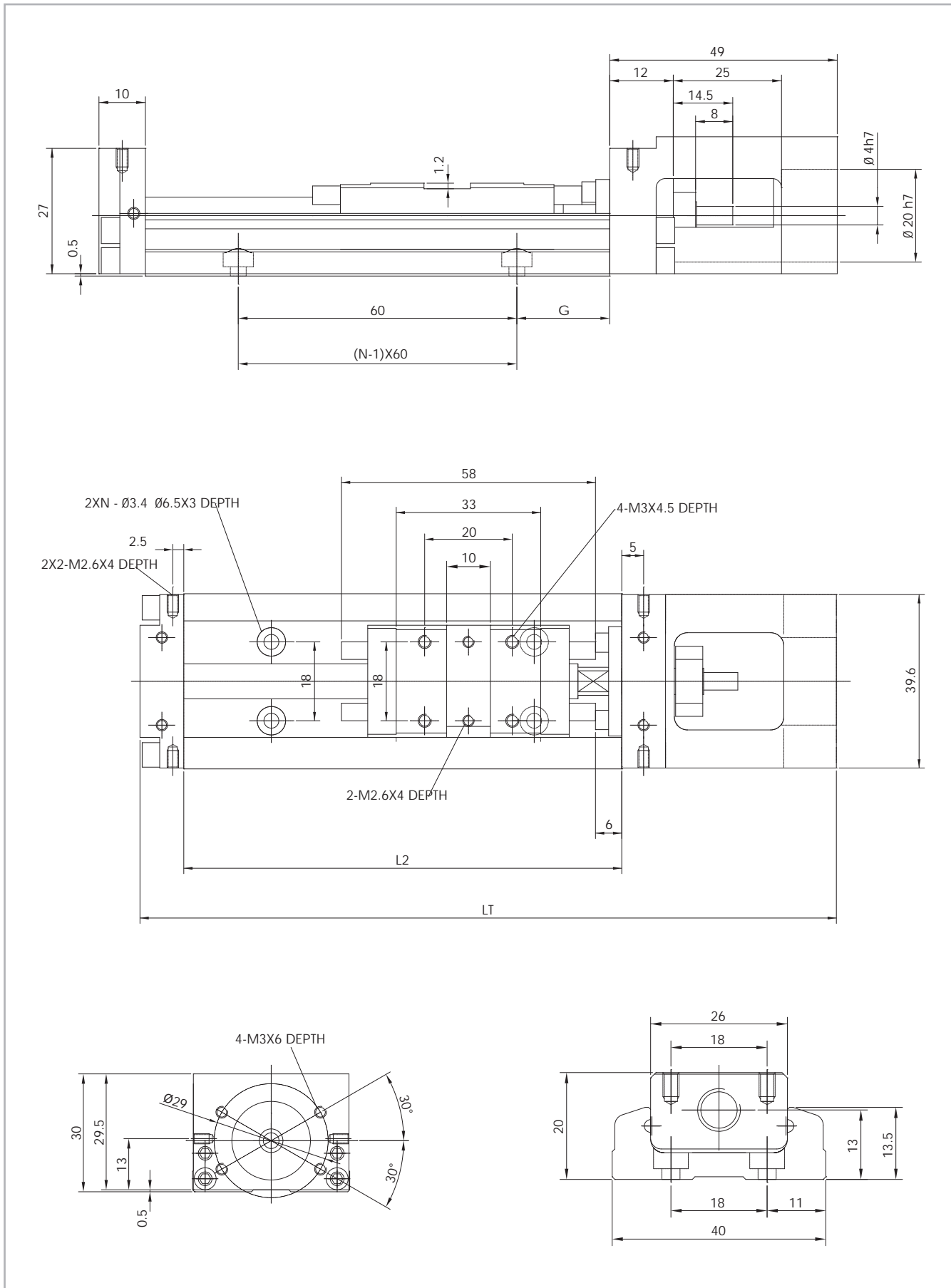

Fig. 53

Technical data

	Type		
	TK 40		
Useful stroke 1 carriage CU1 [mm]	36	86	136
Useful stroke 2 carriages CU2 [mm]	-	34	84
G Dimension [mm]	20	15	40
n Dimension [mm]	2	3	3
Max. speed [m/s]	See page PS-60		
Guide length L2 [mm]	100	150	200
Total length LT [mm]	159	209	259
Weight 1 carriage [Kg]	0.48	0.6	0.72
Weight 2 carriages [Kg]	-	0.67	0.79

Tab. 127

Ball screw precision

Type	Starting torque [Nm]		Max. positioning precision [mm/300mm]		Max. repeatability precision [mm]	
	ISO 5	ISO 7	ISO 5	ISO 7	ISO 5	ISO 7
TK 40 / 08-01	0.012	0.008	0.02	-	0.003	0.01

Tab. 128

TK 40 - Load capacity F_x

Type	F_x [N]		
	Screw	Stat.	Dyn.
TK 40	08-01	1284	676

Tab. 129

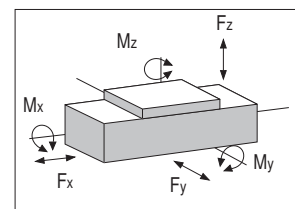

TK 40 - Load capacity

Type	F_y [N]		F_z [N]		M_x [Nm]		M_y [Nm]		M_z [Nm]	
	Stat.	Dyn.	Stat.	Dyn.	Stat.	Dyn.	Stat.	Dyn.	Stat.	Dyn.
TK 40 1 carriage	6468	3920	6468	3920	81	-	33	-	33	-
TK 40 2 carriages	12976	7840	12976	7840	162	-	182	-	182	-

See verification under static load and lifetime on page SL-2 and SL-3

Tab. 130

> TK 60

TK 60 Dimensions

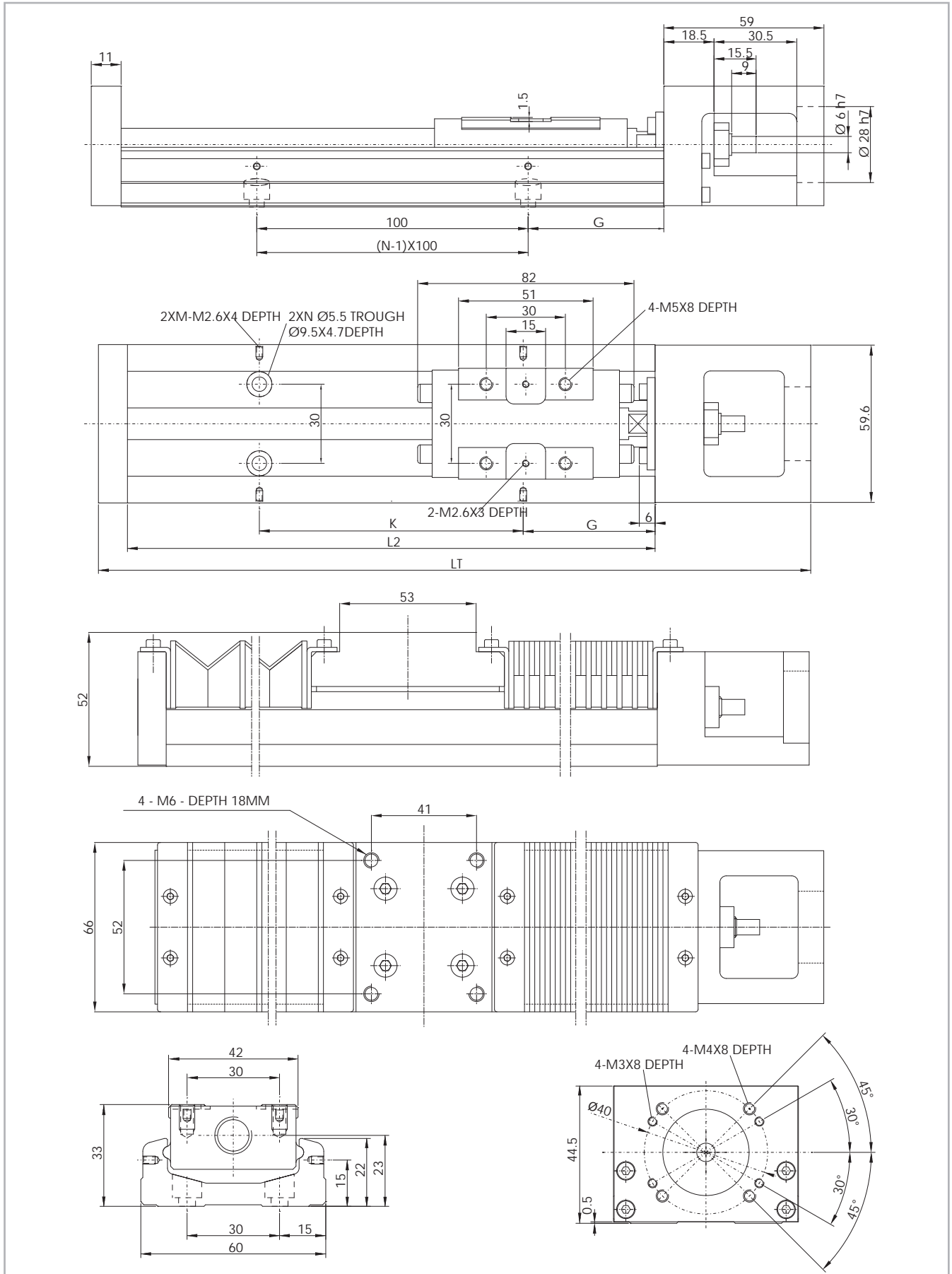

Fig. 54

Technical data

		Type					
		TK 60					
Useful stroke 1 carriage CU1 [mm]	Without bellows	60	110	210	310	410	510
	With bellows	45	77	151	230	300	376
Useful stroke 2 carriages CU2 [mm]	Without bellows	-	-	135	235	335	435
	With bellows	-	-	93	165	241	317
G dimension		25	50	50	50	50	50
K dimension		100	100	200	100	200	100
n dimension [mm]		2	2	3	4	5	6
m dimension		2	3	2	4	3	6
Max. speed [m/s]		See page PS-60					
Guide length L2 [mm]		150	200	300	400	500	600
Total length LT [mm]		220	270	370	470	570	670
Weight 1 carriage [Kg]		1.5	1.8	2.4	3	3.6	4.2
Weight 2 carriages [Kg]		-	-	2.7	3.3	3.9	4.6

Tab. 131

Ball screw precision

Type	Starting torque [Nm]		Max. positioning precision [mm/300mm]		Max. repeatability precision [mm]	
	ISO 5	ISO 7	ISO 5	ISO 7	ISO 5	ISO 7
TK 60 / 12-05	0.15	0.07	0.02	-	0.003	0.01
TK 60 / 12-10	0.15	0.07	0.025	-	0.003	0.01

Tab. 132

TK 60 - Load capacity F_x

Type	F_x [N]		
	Screw	Stat.	Dyn.
TK 60	12-05	5625	3377
	12-10	3234	2107

Tab. 133

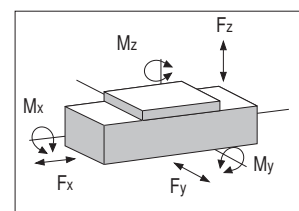

TK 60 - Load capacity

Type	F_y [N]		F_z [N]		M_x [Nm]		M_y [Nm]		M_z [Nm]	
	Stat.	Dyn.	Stat.	Dyn.	Stat.	Dyn.	Stat.	Dyn.	Stat.	Dyn.
TK 60 1 carriage	21462	13230	21462	13230	419	-	152	-	152	-
TK 60 2 carriages	42924	26460	42924	26460	838	-	348	-	348	-

See verification under static load and lifetime on page SL-2 and SL-3

Tab. 134

> TK 80

TK 80 Dimensions

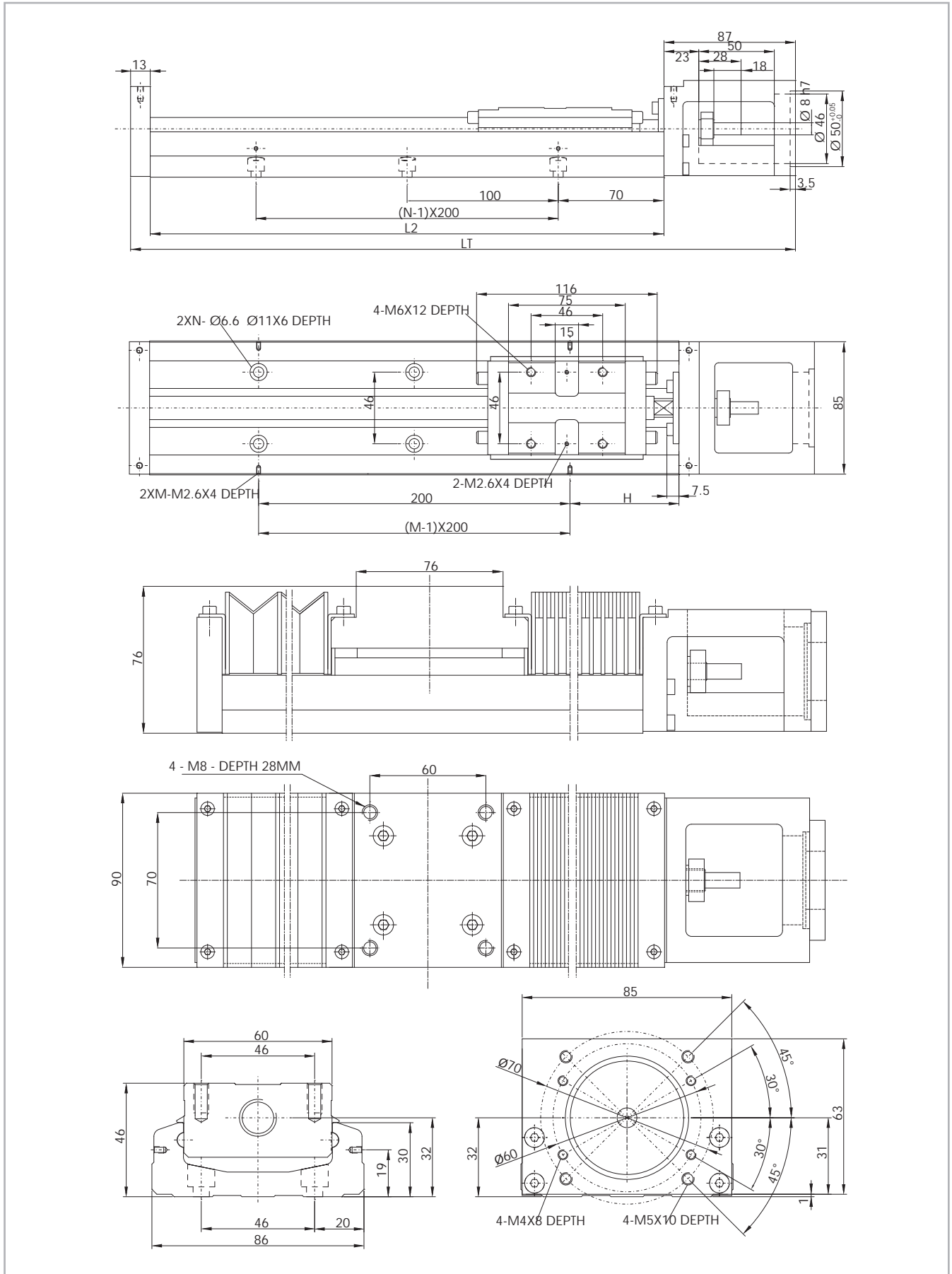

Fig. 55

Technical data

		Type					
		TK 80					
Useful stroke 1 carriage CU1 [mm]	Without bellows	210	310	410	510	610	810
	With bellows	174	248	327	410	491	654
Useful stroke 2 carriages CU2 [mm]	Without bellows	100	200	300	400	500	700
	With bellows	84	158	237	319	399	561
H dimension		70	20	70	20	70	70
n dimension [mm]		3	4	5	6	7	9
m dimension		2	3	3	4	4	5
Max. speed [m/s]		See page PS-60					
Guide length L2 [mm]		340	440	540	640	740	940
Total length LT [mm]		440	540	640	740	840	1040
Weight 1 carriage [Kg]		5.7	6.9	8	9.2	10.4	11.6
Weight 2 carriages [Kg]		6.5	7.7	8.8	10	11.2	12.4

Tab. 135

Ball screw precision

Type	Starting torque [Nm]		Max. positioning precision [mm/300mm]		Max. repeatability precision [mm]	
	ISO 5	ISO 7	ISO 5	ISO 7	ISO 5	ISO 7
TK 80 / 15-10	0.17	0.1	0.03	-	0.003	0.01
TK 80 / 15-20	0.17	0.1	0.03	-	0.003	0.01

Tab. 136

TK 80 - Load capacity F_x

Type	F_x [N]		
	Screw	Stat.	Dyn.
TK 80	15-10	11387	6429
	15-20	6889	4175

Tab. 137

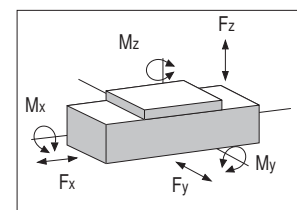

TK 80 - Load capacity

Type	F_y [N]		F_z [N]		M_x [Nm]		M_y [Nm]		M_z [Nm]	
	Stat.	Dyn.	Stat.	Dyn.	Stat.	Dyn.	Stat.	Dyn.	Stat.	Dyn.
TK 80 1 carriage	50764	31458	50764	31458	1507	-	622	-	622	-
TK 80 2 carriages	101348	62916	101348	62916	3014	-	3050	-	3050	-

See verification under static load and lifetime on page SL-2 and SL-3

Tab. 138

> Critical speed

Type	Ball screw lead [mm]	Rail length [mm]	Maximum speed [m/sec]	
			ISO 5	ISO 7
TK 40/08-01	1	100	0.190	0.190
		150	0.190	0.190
		200	0.190	0.190
TK 60/12-05	5	150	0.550	0.390
		200	0.550	0.390
		300	0.550	0.390
		400	0.550	0.390
		500	0.550	0.390
		600	0.340	0.340
		TK 60/12-10	10	150
200	1.100	0.790		
300	1.100	0.790		
400	1.100	0.790		
500	1.100	0.790		
600	0.670	0.670		
TK 80/15-10	10	340	0.740	0.520
		440	0.740	0.520
		540	0.740	0.520
		640	0.740	0.520
		740	0.740	0.520
		940	n.a.	0.430
TK 80/15-20	20	340	1.480	1.050
		440	1.480	1.050
		540	1.480	1.050
		640	1.480	1.050
		740	1.480	1.050
		940	1.220	0.870

Tab. 139

Ordering key



> Identification code for the TK linear units

K	04	0801	5P	0800	1A	
	04=40	08-01	5P=ISO 5		1A = 1 carriage	
	06=60	12-05	7N=ISO 7		2A = 2 carriages	
	08=80	12-10				
		15-10				
		15-20				
					Carriage configuration code	
				L=total length of th unit		
			Type see from pg. PS-52 to pg. PS-56, tab. 131, 135, 139			
		B/S diameter and lead				
	Size see from pg. PS-52 to pg. PS-56					
Linear unit series TK see pg. PS-50						

In order to create identification codes for Actuator Line, you can visit: <http://configureactuator.rollon.com>

Multiaxis systems



Rollon Precision System series linear units have been specifically designed to be modular and therefore to permit fast, trouble-free setup of multi-axis systems. Rollon can provide all the connection elements necessary for combining the various sizes and lengths of Precision System series linear units.

System with 2 horizontal axes

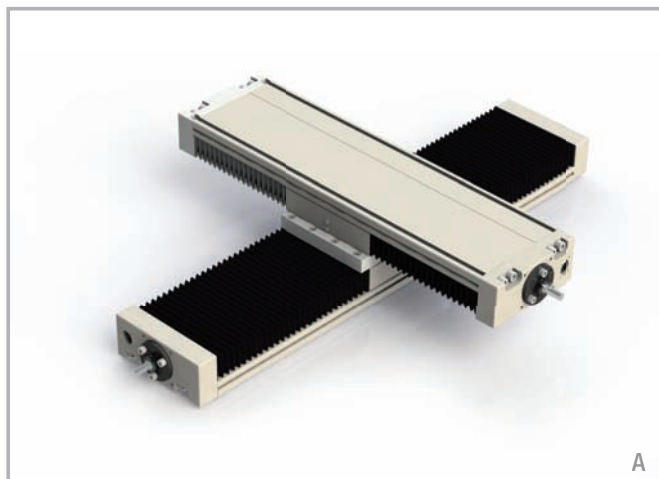

A - Direct fastening of the Y-axis on the X-axis ("base unit on carriage" assembly) using screws without intermediate brackets.

Three-axes system

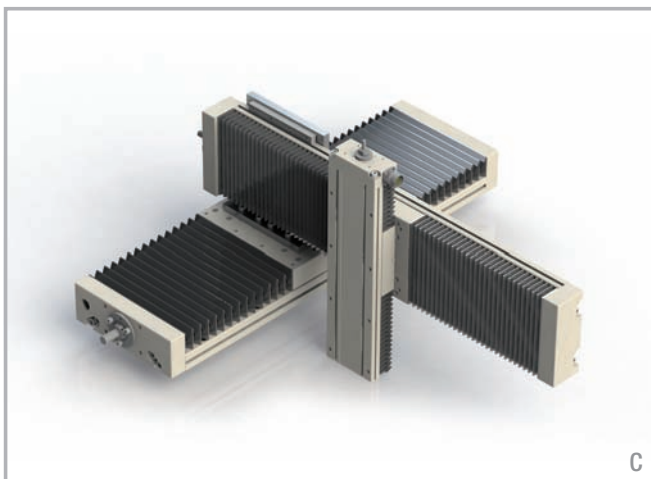

C - Fastening of the Y-axis on the X-axis ("base unit on carriage" assembly) using 90° brackets. Fastening of the Z-axis on the Y-axis ("carriage on carriage" assembly) using a "cross" plate.

System with 2 horizontal axes

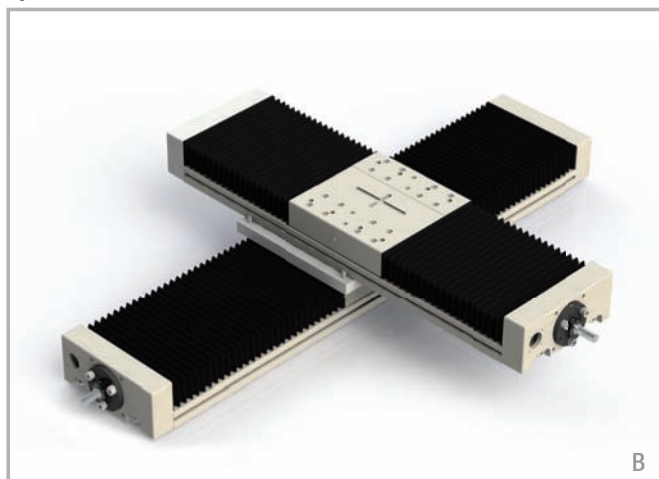

B - Fastening of the Y-axis on the X-axis ("carriage on carriage" assembly) using a "cross" plate.

Three-axes system

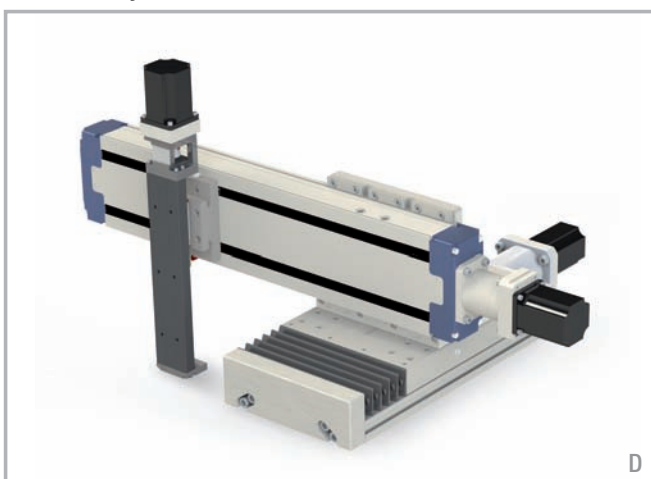

D - Fastening of the Y-axis on the X-axis ("base unit on carriage" assembly) using 90° brackets.

Connection plates are available only upon request

Static load and service life Plus-Clean Room-Smart-Eco-Precision

> Static load

In the static load test, the radial load rating F_y , the axial load rating F_z , and the moments M_x , M_y und M_z indicate the maximum allowed load values. Higher loads will impair the running characteristics. To check the static load, a safety factor S_0 is used, which accounts for the special conditions of the application defined in more detail in the table below:

Safety factor S_0

No shocks or vibrations, smooth and low-frequency change in direction High mounting accuracy, no elastic deformations, clean environment	2 - 3
Normal assembly conditions	3 - 5
Shocks and vibrations, high-frequency changes in direction, substantial elastic deformations	5 - 7

Fig. 1

The ratio of the actual to the maximum allowed load must not be higher than the reciprocal value of the assumed safety factor S_0 .

$\frac{P_{fy}}{F_y} \leq \frac{1}{S_0}$	$\frac{P_{fz}}{F_z} \leq \frac{1}{S_0}$	$\frac{M_1}{M_x} \leq \frac{1}{S_0}$	$\frac{M_2}{M_y} \leq \frac{1}{S_0}$	$\frac{M_3}{M_z} \leq \frac{1}{S_0}$
---	---	--------------------------------------	--------------------------------------	--------------------------------------

Fig. 2

The above formulae only apply to a one load case. If one or more of the forces described are acting simultaneously, the following calculation must be carried out:

$\frac{P_{fy}}{F_y} + \frac{P_{fz}}{F_z} + \frac{M_1}{M_x} + \frac{M_2}{M_y} + \frac{M_3}{M_z} \leq \frac{1}{S_0}$	P_{fy}	= acting load (y direction) (N)
	F_y	= static load rating (y direction) (N)
	P_{fz}	= acting load (z direction) (N)
	F_z	= static load rating (z direction) (N)
	M_1, M_2, M_3	= external moments (Nm)
	M_x, M_y, M_z	= maximum allowed moments in the different load directions (Nm)

Fig. 3

The safety factor S_0 can be at the lower limit given if the acting forces can be determined with sufficient accuracy. If shocks and vibrations act on the system, the higher value should be selected. In dynamic applications, higher safeties are required. For further information, please contact our Application Engineering Department.

Belt safety factor referred to the dynamic F_x

Impact and vibrations	Speed / acceleration	Orietation	Safety Factor
No impacts and/or vibrations	Low	horizontal	1.4
		vertical	1.8
Light impacts and/or vibrations	Medium	horizontal	1.7
		vertical	2.2
Strong impacts and/or vibrations	High	horizontal	2.2
		vertical	3

Tab. 1

> Service life

Calculation of the service life

The dynamic load rating C is a conventional quantity used for calculating the service life. This load corresponds to a nominal service life of 100 km.

The calculated service life, dynamic load rating and equivalent load are linked by the following formula:

$$L_{km} = 100 \text{ km} \cdot \left(\frac{Fz\text{-dyn}}{P_{eq}} \cdot \frac{1}{f_i} \right)^3$$

L_{km} = theoretical service life (km)
 $Fz\text{-dyn}$ = dynamic load rating (N)
 P_{eq} = acting equivalent load (N)
 f_i = service factor (see tab. 2)

Fig. 4

The effective equivalent load P_{eq} is the sum of the forces and moments acting simultaneously on a slider. If these different load components are known, P is obtained from the following equation:

For SP types

$$P_{eq} = P_{fy} + P_{fz} + \left(\frac{M_1}{M_x} + \frac{M_2}{M_y} + \frac{M_3}{M_z} \right) \cdot F_y$$

Fig. 5

For CI and CE types

$$P_{eq} = P_{fy} + \left(\frac{P_{fz}}{F_z} + \frac{M_1}{M_x} + \frac{M_2}{M_y} + \frac{M_3}{M_z} \right) \cdot F_y$$

Fig. 6

The external constants are assumed to be constant over time. Short-term loads that do not exceed the maximum load ratings have no relevant effect on the service life and can therefore be neglected in the calculation.

Service factor f_i

f_i	
no shocks or vibrations, smooth and low-frequency changes in direction; ($\alpha < 5\text{m/s}^2$) clean operating conditions; low speeds ($<1 \text{ m/s}$)	1.5 - 2
Slight vibrations; medium speeds; (1-2 m/s) and medium-high frequency of the changes in direction ($5\text{m/s}^2 < \alpha < 10 \text{ m/s}^2$)	2 - 3
Shocks and vibrations; high speeds ($>2 \text{ m/s}$) and high-frequency changes in direction; ($\alpha > 10\text{m/s}^2$) high contamination, very short stroke	> 3

Tab. 2

Static load and service life Uniline

> Static load

In the static load test, the radial load rating C_{0rad} , the axial load rating C_{0ax} , and the moments M_x , M_y und M_z indicate the maximum allowed load values. Higher loads will impair the running characteristics. To check the static load, a safety factor S_0 is used, which accounts for the special conditions of the application defined in more detail in the table below:

Safety factor S_0

No shocks or vibrations, smooth and low-frequency change in direction High mounting accuracy, no elastic deformations, clean environment	1 - 1.5
Normal assembly conditions	1.5 - 2
Shocks and vibrations, high-frequency changes in direction, substantial elastic deformations	2 - 3.5

Fig. 7

The ratio of the actual to the maximum allowed load must not be higher than the reciprocal value of the assumed safety factor S_0 .

$\frac{P_{Orad}}{C_{Orad}} \leq \frac{1}{S_0}$	$\frac{P_{Oax}}{C_{Oax}} \leq \frac{1}{S_0}$	$\frac{M_1}{M_x} \leq \frac{1}{S_0}$	$\frac{M_2}{M_y} \leq \frac{1}{S_0}$	$\frac{M_3}{M_z} \leq \frac{1}{S_0}$
--	--	--------------------------------------	--------------------------------------	--------------------------------------

Fig. 8

The above formulae apply to a one load case. If one or more of the forces described are acting simultaneously, the following test must be carried out:

$\frac{P_{Orad}}{C_{Orad}} + \frac{P_{Oax}}{C_{Oax}} + \frac{M_1}{M_x} + \frac{M_2}{M_y} + \frac{M_3}{M_z} \leq \frac{1}{S_0}$	<ul style="list-style-type: none"> P_{Orad} = acting radial load (N) C_{Orad} = allowed radial load (N) P_{Oax} = acting axial load (N) C_{Oax} = allowed axial load (N) M_1, M_2, M_3 = external moments (Nm) M_x, M_y, M_z = maximum allowed moments in the different load directions (Nm)
--	--

Fig. 9

The safety factor S_0 can be at the lower limit given if the acting forces can be determined with sufficient accuracy. If shocks and vibrations act on the system, the higher value should be selected. In dynamic applications, higher safeties are required. For further information, please contact our Application Engineering Department.

> Calculation formulae

Moments M_y and M_z for linear units with long slider plate

The allowed loads for the moments M_y and M_z depend on the length of the slider plate. The allowed moments M_{zn} and M_{yn} for each slider plate length are calculated by the following formulae:

$$S_n = S_{\min} + n \cdot \Delta S$$

$$M_{zn} = \left(1 + \frac{S_n - S_{\min}}{K} \right) \cdot M_{z \min}$$

$$M_{yn} = \left(1 + \frac{S_n - S_{\min}}{K} \right) \cdot M_{y \min}$$

M_{zn} = allowed moment (Nm)

$M_{z \min}$ = minimum values (Nm)

M_{yn} = allowed moment (Nm)

$M_{y \min}$ = minimum values (Nm)

S_n = length of the slider plate (mm)

S_{\min} = minimum length of the slider plate (mm)

ΔS = factor of the change in slider length

K = constant

Fig. 10

Type	$M_{y \min}$ [Nm]	$M_{z \min}$ [Nm]	S_{\min} [mm]	ΔS	K
A40L	22	61	240	10	74
A55L	82	239	310		110
A75L	287	852	440		155
C55L	213	39	310		130
C75L	674	116	440		155
E55L	165	239	310		110
E75L	575	852	440		155
ED75L (M_z)	1174	852	440		155
ED75L (M_y)	1174	852	440		270

Tab. 3

Moments M_y and M_z for linear units with two slider plates

The allowed loads for the moments M_y and M_z are related to the value of the distance between the centers of the sliders. The allowed moments $M_{y,n}$ and $M_{z,n}$ for each distance between the centers of the sliders are calculated by the following formulae:

$L_n = L_{min} + n \cdot \Delta L$ $M_y = \left(\frac{L_n}{L_{min}} \right) \cdot M_{y,min}$ $M_z = \left(\frac{L_n}{L_{min}} \right) \cdot M_{z,min}$	<p>M_y = allowed moment (Nm)</p> <p>M_z = allowed moment (Nm)</p> <p>$M_{y,min}$ = minimum values (Nm)</p> <p>$M_{z,min}$ = minimum values (Nm)</p> <p>L_n = distance between the centers of the sliders (mm)</p> <p>L_{min} = minimum value for the distance between the centers of the sliders (mm)</p> <p>ΔL = factor of the change in slider length</p>
--	--

Fig. 11

Type	$M_{y,min}$ [Nm]	$M_{z,min}$ [Nm]	L_{min} [mm]	ΔL
A40D	70	193	235	5
A55D	225	652	300	5
A75D	771	2288	416	8
A100D	2851	4950	396	50
C55D	492	90	300	5
C75D	1809	312	416	8
E55D	450	652	300	5
E75D	1543	2288	416	8
ED75D	3619	2288	416	8

Tab. 4

> Service life

Calculation of the service life

The dynamic load rating C is a conventional quantity used for calculating the service life. This load corresponds to a nominal service life of 100 km. The corresponding values for each liner unit are listed in Table 45 shown

below. The calculated service life, dynamic load rating and equivalent load are linked by the following formula:

$L_{km} = 100 \text{ km} \cdot \left(\frac{C}{P} \cdot \frac{f_c}{f_i} \cdot f_n \right)^3$	<p>L_{km} = theoretical service life (km)</p> <p>C = dynamic load rating (N)</p> <p>P = acting equivalent load (N)</p> <p>f_i = service factor (see tab. 5)</p> <p>f_c = contact factor (see tab. 6)</p> <p>f_n = stroke factor (see fig. 13)</p>
--	---

Fig. 12

The effective equivalent load P is the sum of the forces and moments acting simultaneously on a slider. If these different load components are known, P is obtained from the following equation:

$$P = P_r + \left(\frac{P_a}{C_{0ax}} + \frac{M_1}{M_x} + \frac{M_2}{M_y} + \frac{M_3}{M_z} \right) \cdot C_{0rad}$$

Fig. 13

The external constants are assumed to be constant over time. Short-term loads that do not exceed the maximum load ratings have no relevant effect on the service life and can therefore be neglected in the calculation.

Service factor f_i

f_i	
No shocks or vibrations, smooth and low-frequency changes in direction; clean operating conditions; low speeds (<1 m/s)	1 - 1.5
Slight vibrations; medium speeds; (1-2,5 m/s) and medium-high frequency of the changes in direction	1.5 - 2
Shocks and vibrations; high speeds (>2.5 m/s) and high-frequency changes in direction; high contamination	2 - 3.5

Tab. 5

Contact factor f_c

f_c	
Standard slider	1
Long slider	0.8
Double slider	0.8

Tab. 6

Stroke factor f_h

The stroke factor f_h accounts for the higher stress on the raceways and rollers when short strokes are carried out at the same total run distance. The following diagram shows the corresponding values (for strokes above 1 m, f_h remains 1):

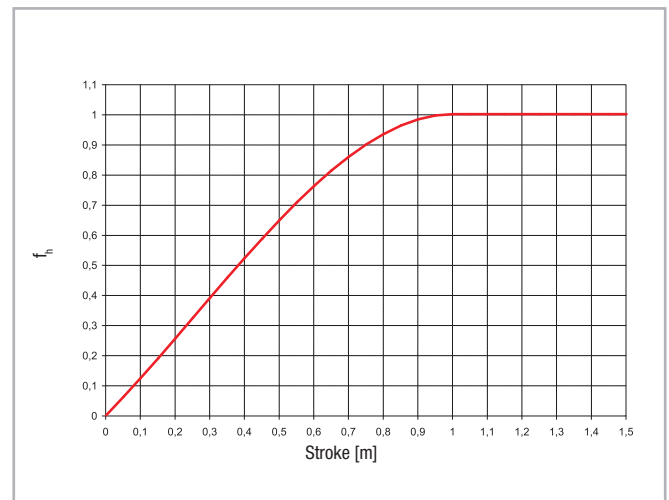

Fig. 14

> Determination of the motor torque

The torque C_m required at the drive head of the linear axis is calculated by the following formula:

$$C_m = C_v + \left(F \cdot \frac{D_p}{2} \right)$$

- C_m = torque of the motor (Nm)
- C_v = starting torque (Nm)
- F = force acting on the toothed belt (N)
- D_p = pitch diameter of pulley (m)

Fig. 15

Data sheet

General data: **Date:** **Inquiry N°:**
Address: **Contact:**
Company: **Date:**
Phone: **Fax:**

Technical data:

			X axis	Y axis	Z axis
Useful stroke (Including safety overtravel)	S	[mm]			
Load to be translated	P	[kg]			
Location of Load in the	X-Direction	LxP	[mm]		
	Y-Direction	LyP	[mm]		
	Z-Direction	LzP	[mm]		
Additional force	Direction (+/-)	Fx (Fy, Fz)	[N]		
Position of force	X-Direction	Lx Fx (Fy, Fz)	[mm]		
	Y-Direction	Ly Fx (Fy, Fz)	[mm]		
	Z-Direction	Lz Fx (Fy, Fz)	[mm]		
Assembly position (Horizontal/Vertical/Transversal)					
Max. speed	V	[m/s]			
Max. acceleration	a	[m/s ²]			
Positioning repeatability	Δs	[mm]			
Required life	L	yrs			

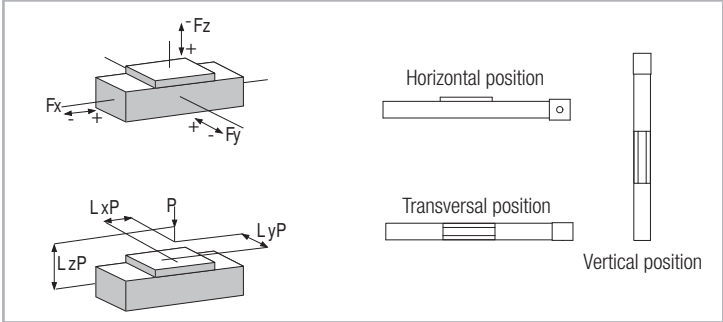

Attention: Please enclose drawing, sketches and sheet of the duty cycle



ROLLON S.p.A. - ITALY ▼

Via Trieste 26
I-20871 Vimercate (MB)
Phone: (+39) 039 62 59 1
www.rollon.it - infocom@rollon.it

● Rollon Branches & Rep. Offices
● Distributors

Branches:

ROLLON GmbH - GERMANY ▼

Bonner Strasse 317-319
D-40589 Düsseldorf
Phone: (+49) 211 95 747 0
www.rollon.de - info@rollon.de

ROLLON B.V. - NETHERLANDS ▼

Ringbaan Zuid 8
6905 DB Zevenaar
Phone: (+31) 316 581 999
www.rollon.nl - info@rollon.nl

Rep. Offices:

ROLLON S.p.A. - RUSSIA ▼

117105, Moscow, Varshavskoye
shosse 17, building 1
Phone: +7 (495) 508-10-70
www.rollon.ru - info@rollon.ru

ROLLON S.A.R.L. - FRANCE ▼

Les Jardins d'Eole, 2 allée des Séquoias
F-69760 Limonest
Phone: (+33) (0) 4 74 71 93 30
www.rollon.fr - infocom@rollon.fr

ROLLON Corporation - USA ▼

101 Bilby Road, Suite B
Hackettstown, NJ 07840
Phone: (+1) 973 300 5492
www.rolloncorp.com - info@rolloncorp.com

ROLLON Ltd - UK ▼

The Works 6 West Street Olney
Buckinghamshire, United Kingdom, MK46 5 HR
Phone: +44 (0) 1234964024
www.rollon.uk.com - info@rollon.uk.com

ROLLON Ltd - CHINA ▼

No. 16 Jin Wen Road,
China, Shanghai, 201323
Phone: +86 21 5811 8288
www.rollon.cn.com - info@rollon.cn.com

ROLLON India Pvt. Ltd. - INDIA ▼

1st floor, Regus Gem Business Centre, 26/1
Hosur Road, Bommanahalli, Bangalore 560068
Phone: (+91) 80 67027066
www.rollonindia.in - info@rollonindia.in

Regional Manager:

ROLLON - SOUTH AMERICA ▼

R. Joaquim Floriano, 397, 2o. andar
Itaim Bibi - 04534-011, São Paulo, BRASIL
Phone: +55 (11) 3198 3645
www.rollonbrasil.com.br - info@rollonbrasil.com

ROLLON - JAPAN ▼

3F Shiodome Building, 1-2-20 Kaigan, Minato-ku,
Tokyo 105-0022 Japan
Phone +81 3 6721 8487
www.rollon.jp - info@rollon.jp

Consult the other ranges of products



Distributor

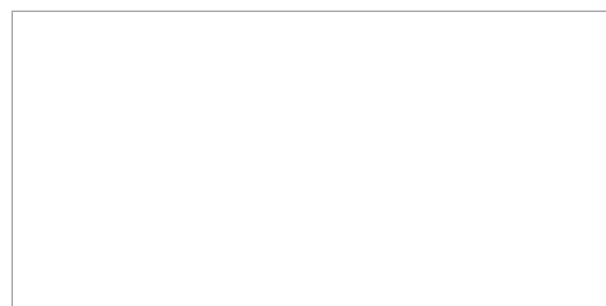

All addresses of our global sales partners can also be found at www.rollon.com

The content of this document and its use are subject to the general terms of sale of ROLLON available on the web site www.rollon.com
Changes and errors expected. The text and images may be used only with our permission.